

Service
Service
Service



Service Manual

TABLE OF CONTENTS

	Page
Location of PC Boards & Versions Variation	1-2
Specifications	1-3
Measurement Setup	1-4
Service Aids, Safety Instruction, etc	1-5 to 1-7
Preparations & Controls	1-8 to 1-9
Troubleshooting	1-10
Disassembly Instructions & Service positions	2
Service Test Program	3-1
Set Block Diagram	4-1
Set Wiring Diagram	5-1
Front Board	6
ECO Tuner Part : Systems Cenelec	7B
Main Board	8
ETF8 Tape Module	9
CD-MP3-WMA 5250 Module	10
Combi & Regulator Board	11
Mechanical Exploded View & Parts List	12



3141 785 30210

© Copyright 2005 Philips Consumer Electronics B.V. Eindhoven, The Netherlands
All rights reserved. No part of this publication may be reproduced, stored in a retrieval system or transmitted, in any form or by any means, electronic, mechanical, photocopying, or otherwise without the prior permission of Philips.

Published by SL0521 Service Audio Printed in The Netherlands Subject to modification.

Version 1.0



PHILIPS

SPECIFICATIONS**GENERAL:**

Mains voltage	: 220-230V for /22/25
Power consumption	: 80W at 1/8 P _{rated} < 15W at Standby (Demo mode off) < 0.5W at ECO Standby
Clock accuracy	: < 4 seconds per day
Dimension centre unit	: 175 x 252 x 350mm

TUNER:**FM**

Tuning range	: 87.5-108MHz
Grid	: 50kHz
IF frequency	: 10.7MHz ± 25kHz
Aerial input	: 75 Ω coaxial
Sensitivity at 26dB S/N	: < 7μV
Selectivity at 600kHz bandwidth	: > 25dB
Image rejection	: > 25dB [> 75dB]
Distortion at RF=1mV, dev. 75kHz	: < 3%
-3dB Limiting point	: < 8μV
Crosstalk at RF=1mV, dev. 40kHz	: > 18dB

MW

Tuning range	: 531-1602kHz
Grid	: 9kHz
IF frequency	: 450kHz ± 1kHz
Aerial input	: Frame aerial
Sensitivity at 26dB S/N	: < 4.4mV/M
Selectivity at 18kHz bandwidth	: > 18dB
IF rejection	: > 45dB
Image rejection	: > 28dB
Distortion at RF=50mV, M=80%	: < 5%

AMPLIFIER:

Output power (6 Ω, 1kHz, 10% THD)	
L & R	: 2 x 50W RMS
Frequency response within -3dB	: 50Hz-16kHz
Bass	: 60Hz ± 3 Steps
Treble	: 12kHz ± 3 Steps
Incredible Surround	: On / Off
Input sensitivity	
Aux in (at 1kHz)	: 500mV at 600 Ω
CDR in (at 1kHz)	: 1000mV at 600 Ω
Output sensitivity	
Headphone output at 32 ohm	: 15mW ± 2dB (Max. vol.)
CD Headphone output at 32 ohm	: 5mW ± 2dB (Max. vol.)

CASSETTE RECORDER:

Number of track	: 2 tracks (stereo)
Tape speed	: 4.76 cm/sec ± 2%
Wow and flutter	: < 0.4% DIN
Fast-wind/Rewind time C60	: 130 sec
Bias system	: 78kHz ± 10kHz
Rec/Pb frequency response within 8dB	: 80Hz - 10kHz
Signal to Noise Ratio (Type I)	: > 48dBA
Signal to Noise Ratio (Type II)	: > 52dBA

COMPACT DISC:

Measurement done directly at the connector on the board.	
Output Resistance	: < 100 Ω
Output Voltage (0dB, 1kHz)	: 0.5Vrms ± 1dB (unloaded)
Channel Unbalance	: < ±1dB
Channel Separation (1kHz)	: > 60dB
Frequency Response (3dB)	: 20Hz-20kHz
Signal to Noise Ratio	: > 76dBA
MP3-CD Bit Rate	: 32-256 kbps
Sampling Frequencies	: 32, 44.1, 48 kHz

[...] Values indicated are for "ECO6 Cenelec Board" only.

MEASUREMENT SETUP

Tuner FM

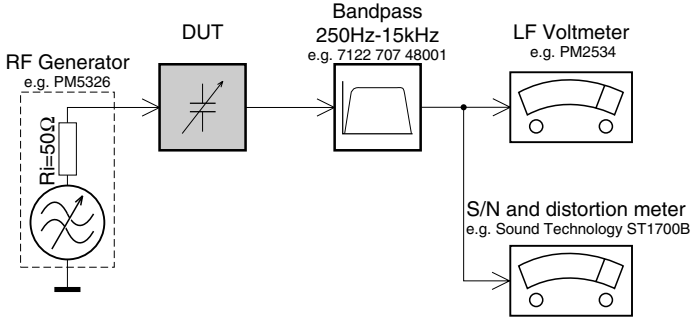

Use a bandpass filter to eliminate hum (50Hz, 100Hz) and disturbance from the pilotone (19kHz, 38kHz).

Tuner AM (MW,LW)

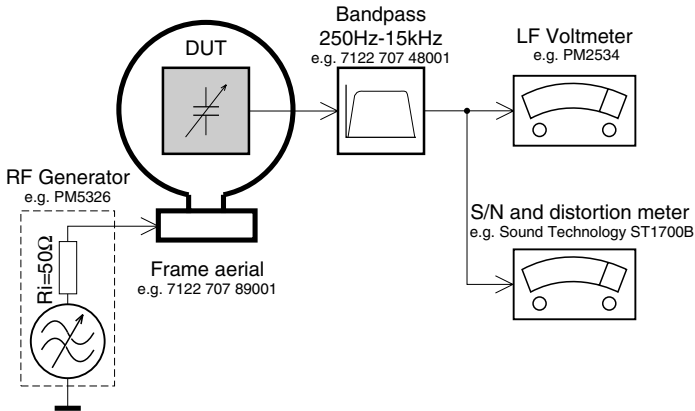

To avoid atmospheric interference all AM-measurements have to be carried out in a Faraday's cage. Use a bandpass filter (or at least a high pass filter with 250Hz) to eliminate hum (50Hz, 100Hz).

CD

Use Audio Signal Disc SBC429 4822 397 30184 (replaces test disc 3)

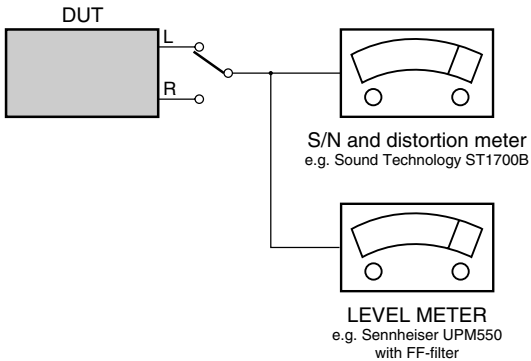

Recorder

Use Universal Test Cassette **CrO2** SBC419 4822 397 30069 or Universal Test Cassette **Fe** SBC420 4822 397 30071

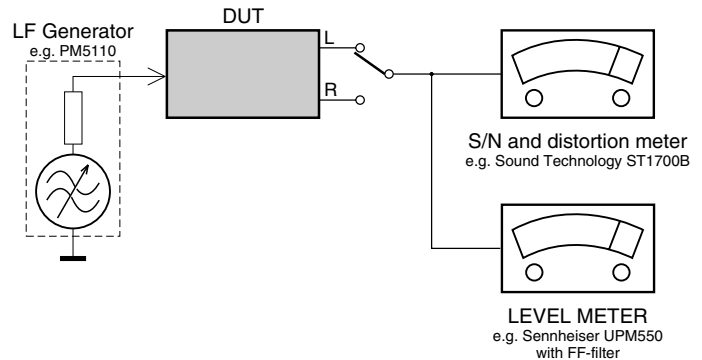

SERVICE AIDS

Service Tools:

Universal Torx driver holder	4822 395 91019
Torx bit T10 150mm	4822 395 50456
Torx driver set T6 - T20	4822 395 50145
Torx driver T10 extended	4822 395 50423

Compact Disc:

SBC426/426A Test disc 5 + 5A	4822 397 30096
SBC442 Audio Burn-in Test disc 1kHz	4822 397 30155
SBC429 Audio Signals disc	4822 397 30184
Dolby Pro-logic Test Disc	4822 395 10216

HANDLING CHIP COMPONENTS

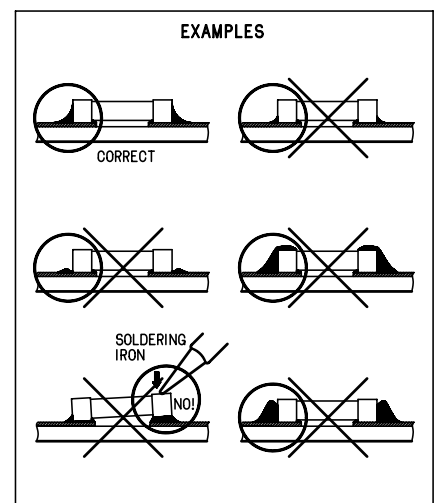
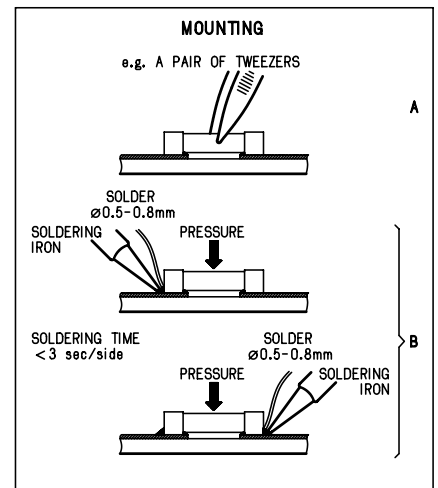
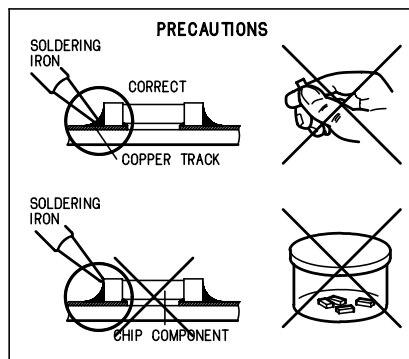
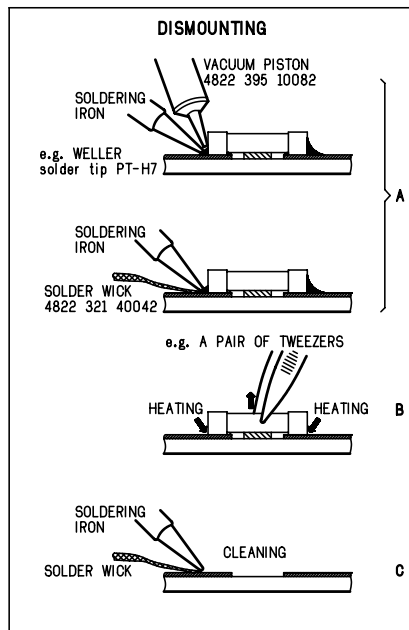
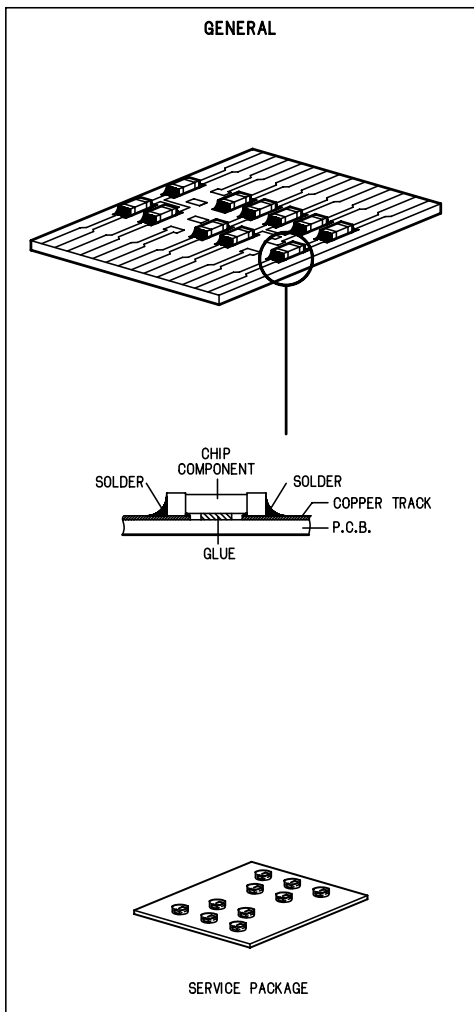

(GB) WARNING

All ICs and many other semi-conductors are susceptible to electrostatic discharges (ESD). Careless handling during repair can reduce life drastically.

When repairing, make sure that you are connected with the same potential as the mass of the set via a wrist wrap with resistance. Keep components and tools also at this potential.

(F) ATTENTION

Tous les IC et beaucoup d'autres semi-conducteurs sont sensibles aux décharges statiques (ESD).

Leur longévité pourrait être considérablement écourtée par le fait qu'aucune précaution n'est prise à leur manipulation.

Lors de réparations, s'assurer de bien être relié au même potentiel que la masse de l'appareil et enfilez le bracelet serti d'une résistance de sécurité.

Veiller à ce que les composants ainsi que les outils que l'on utilise soient également à ce potentiel.

(D) WARNUNG

Alle ICs und viele andere Halbleiter sind empfindlich gegenüber elektrostatischen Entladungen (ESD).

Unvorsichtige Behandlung im Reparaturfall kann die Lebensdauer drastisch reduzieren.

Veranlassen Sie, dass Sie im Reparaturfall über ein Pulsarmband mit Widerstand verbunden sind mit dem gleichen Potential wie die Masse des Gerätes.

Bauteile und Hilfsmittel auch auf dieses gleiche Potential halten.

(NL) WAARSCHUWING

Alle IC's en vele andere halfgeleiders zijn gevoelig voor electrostatische ontladingen (ESD). Onzorgvuldig behandelen tijdens reparatie kan de levensduur drastisch doen verminderen.

Zorg ervoor dat u tijdens reparatie via een polsband met weerstand verbonden bent met hetzelfde potentiaal als de massa van het apparaat.

Houd componenten en hulpmiddelen ook op hetzelfde potentiaal.

(I) AVVERTIMENTO

Tutti IC e parecchi semi-conduttori sono sensibili alle scariche statiche (ESD).

La loro longevità potrebbe essere fortemente ridotta in caso di non osservazione della più grande cauzione alla loro manipolazione.

Durante le riparazioni occorre quindi essere collegato allo stesso potenziale che quello della massa dell'apparecchio tramite un braccialetto a resistenza.

Assicurarsi che i componenti e anche gli utensili con quali si lavora siano anche a questo potenziale.

ESD**(GB) ESD PROTECTION EQUIPMENT:**

Complete Kit ESD3 (small tablemat, wristband, connection box, extension cable and earth cable) 4822 310 10671
Wristband tester 4822 344 13999

(GB)

Safety regulations require that the set be restored to its original condition and that parts which are identical with those specified, be used

Safety components are marked by the symbol \triangle .

(NL)

Veiligheidsbepalingen vereisen, dat het apparaat bij reparatie in zijn oorspronkelijke toestand wordt teruggebracht en dat onderdelen, identiek aan de gespecificeerde, worden toegepast.

De Veiligheidsonderdelen zijn aangeduid met het symbool \triangle .

(F)

Les normes de sécurité exigent que l'appareil soit remis à l'état d'origine et que soient utilisés les pièces de rechange identiques à celles spécifiées.

Less composants de sécurité sont marqués \triangle .

(D)

Bei jeder Reparatur sind die geltenden Sicherheitsvorschriften zu beachten. Der Originalzustand des Geräts darf nicht verändert werden; für Reparaturen sind Original-Ersatzteile zu verwenden.

Sicherheitsbauteile sind durch das Symbol \triangle markiert.

(I)

Le norme di sicurezza esigono che l'apparecchio venga rimesso nelle condizioni originali e che siano utilizzati i pezzi di ricambio identici a quelli specificati.

Componenti di sicurezza sono marcati con \triangle .

(GB)

After servicing and before returning set to customer perform a leakage current measurement test from all exposed metal parts to earth ground to assure no shock hazard exist. The leakage current must not exceed 0.5mA.

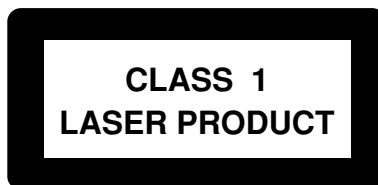
**(GB) Warning !**

Invisible laser radiation when open.
Avoid direct exposure to beam.

(S) Varning !

Osynlig laserstrålning när apparaten är öppnad och spårren är urkopplad. Betrakta ej strålen.

(SF) Varoitus !

Avatussa laitteessa ja suoalukituksen ohitettaessa olet alltiina näkymättömälle laserisäteilylle. Älä katso säteeseen!

(DK) Advarse !

Usynlig laserstrålning ved åbning når sikkerhedsafbrydere er ude af funktion. Undgå udsættelse for strålning.

(F)

"Pour votre sécurité, ces documents doivent être utilisés par des spécialistes agréés, seuls habilités à réparer votre appareil en panne".

INFORMATION ABOUT LEAD-FREE SOLDERING

Philips CE is producing lead-free sets from 1.1.2005 onwards.

IDENTIFICATION:

Regardless of special logo (not always indicated) one must treat all sets from 1 Jan 2005 onwards, according next rules:



Example S/N:

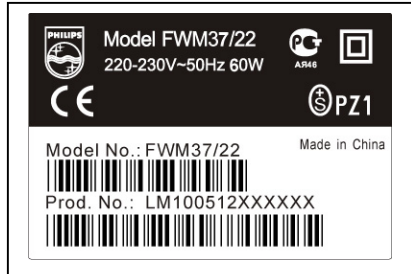

Bottom line of typeplate gives a 14-digit S/N. Digit 5&6 is the year, digit 7&8 is the week number, so in this case 2005 wk12

So from 0501 onwards = from 1 Jan 2005 onwards

Important note: In fact also products of year 2004 must be treated in this way as long as you avoid mixing solder-alloys (leaded/ lead-free). So best to always use SAC305 and the higher temperatures belong to this.

Due to lead-free technology some rules have to be respected by the workshop during a repair:

- Use only lead-free solder alloy Philips SAC305 with order code 0622 149 00106. If lead-free solder-paste is required, please contact the manufacturer of your solder-equipment. In general use of solder-paste within workshops should be avoided because paste is not easy to store and to handle.
- Use only adequate solder tools applicable for lead-free solder alloy. The solder tool must be able
 - To reach at least a solder-temperature of 400°C,
 - To stabilize the adjusted temperature at the solder-tip
 - To exchange solder-tips for different applications.
- Adjust your solder tool so that a temperature around 360°C – 380°C is reached and stabilized at the solder joint. Heating-time of the solder-joint should not exceed ~ 4 sec. Avoid temperatures above 400°C otherwise wear-out of tips will rise drastically and flux-fluid will be destroyed. To avoid wear-out of tips switch off un-used equipment, or reduce heat.
- Mix of lead-free solder alloy / parts with leaded solder alloy / parts is possible but PHILIPS recommends strongly to avoid mixed solder alloy types (leaded and lead-free).
If one cannot avoid or does not know whether product is lead-free, clean carefully the solder-joint from old solder alloy and re-solder with new solder alloy (SAC305).
- Use only original spare-parts listed in the Service-Manuals. Not listed standard-material (commodities) has to be purchased at external companies.
- Special information for BGA-ICs:
 - always use the 12nc-recognizable soldering temperature profile of the specific BGA (for de-soldering always use the lead-free temperature profile, in case of doubt)
 - lead free BGA-ICs will be delivered in so-called 'dry-packaging' (sealed pack including a silica gel pack) to protect the IC against moisture. After opening, dependent of MSL-level seen on indicator-label in the bag, the BGA-IC possibly still has to be baked dry. (MSL=Moisture Sensitivity Level). This will be communicated via AYS-website.
 - Do not re-use BGAs at all.
- For sets produced before 1.1.2005 (except products of 2004), containing leaded solder-alloy and components, all needed spare-parts will be available till the end of the service-period. For repair of such sets nothing changes.
- On our website www.atyourservice.ce.philips.com you find more information to:
 - * BGA-de-/soldering (+ baking instructions)
 - * Heating-profiles of BGAs and other ICs used in Philips-sets

You will find this and more technical information within the "magazine", chapter "workshop news".

For additional questions please contact your local repair-helpdesk.

SERVICE INSTRUCTION

Safety regulations require that after a repair, the set must be returned in its original condition. Pay in particular attention to the following points:

- Route the wire trees correctly and fix them with the mounted cable clamps.
- Check the insulation of the AC Power lead for external damage.
- Check the strain relief of the AC Power cord for proper function.
- Check the electrical DC resistance between the AC Power Plug and the secondary side (only for sets which have a AC Power isolated power supply):
 1. Unplug the AC Power cord and connect a wire between the two pins of the AC Power plug.
 2. Set the AC Power switch to the "on" position (keep the AC Power cord unplugged!).
 3. Measure the resistance value between the pins of the AC Power plug and the metal shielding of the tuner or the aerial connection on the set. The reading should be larger than 4.5 Mohm (For U.S. it should be between 4.2 Mohm and 12 Mohm).
 4. Switch "off" the set, and remove the wire between the two pins of the AC Power plug.
- Check the cabinet for defects, to avoid touching of any inner parts by the customer.

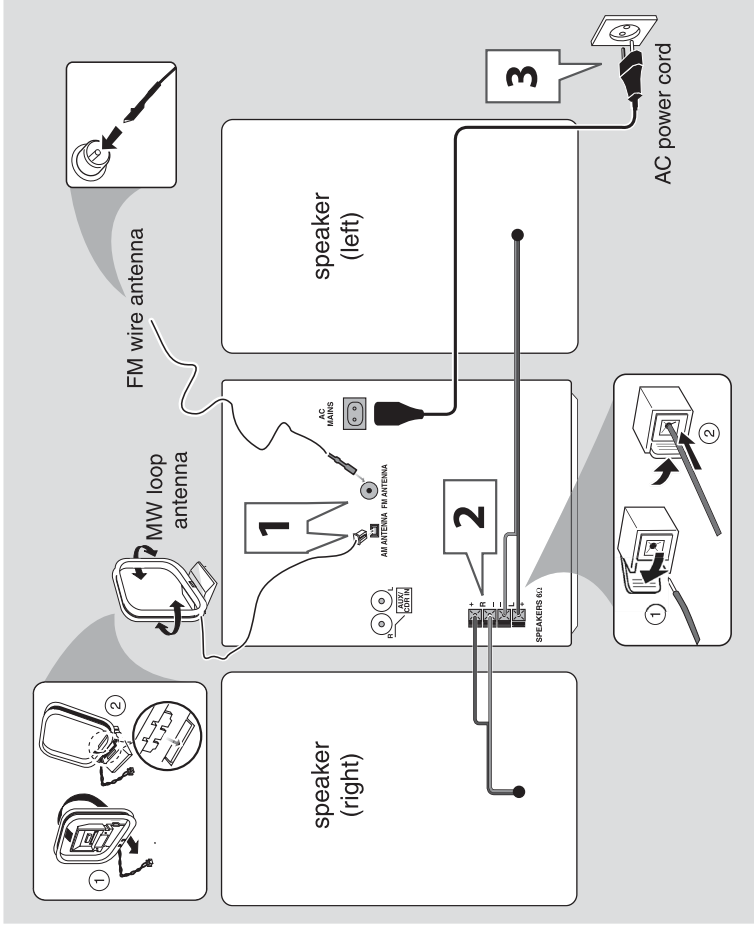

- WARNING!**
- Use only the supplied speakers.
 - The combination of the main unit and speakers provide the best sound. Using other speakers can damage the unit and sound quality will be negatively affected.
 - Never make or change connections with the power switched on.
 - Connect the AC power cord to the power outlet only after you have finished hooking up everything.

- Step 1: Connecting FM/MW antennas**
- Place the MW loop antenna on a shelf or attach it to a stand or wall.
 - Extend the FM antenna and fix its ends to the wall.
 - Adjust the position of the antennas for optimal reception.
 - Position the antennas as far as possible from a TV, VCR or other radiation source to prevent unwanted noise.
 - For better FM stereo reception, connect external FM antenna.

Step 2: Connecting the speakers

Connect the speaker wires to the SPEAKERS terminals, right speaker to "R" and left speaker to "L", coloured (marked) wire to "+" and black (unmarked) wire to "-". Fully insert the stripped portion of the speaker wire into the terminal as shown.

- Helpful Hint:*
- Ensure that the speaker cables are correctly connected. Improper connections may damage the system due to short-circuit.
 - Do not connect more than one speaker to any one pair of + / - speaker terminals.

Step 3: Connecting the AC power cord

"AUTO INSTALL - PRESS PLAY" may appear on the display panel when the AC power cord is plugged into the power outlet for the first time. Press ►|◀ on the main unit to store all available radio stations or press ■ to exit (refer to "Tuner Operations").

Step 4: Inserting batteries into the remote control

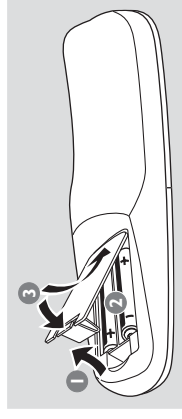

- 1 Open the battery compartment cover.
- 2 Insert two batteries type R06 or AA, following the indications (+ -) inside the compartment.
- 3 Close the cover.

Using the remote control to operate the system

- 1 Aim the remote control directly at the remote sensor (IR) on the main unit.
- 2 Select the source you wish to control by pressing one of the source select keys on the remote control (for example CD, TUNER).
- 3 Then select the desired function (for example ►|◀, ◀, ▶).

CAUTION!

- Remove batteries if they are exhausted or will not be used for a long time.
- Do not use old and new or different types of batteries in combination.
- Batteries contain chemical substances, so they should be disposed of properly.

Functional Overview

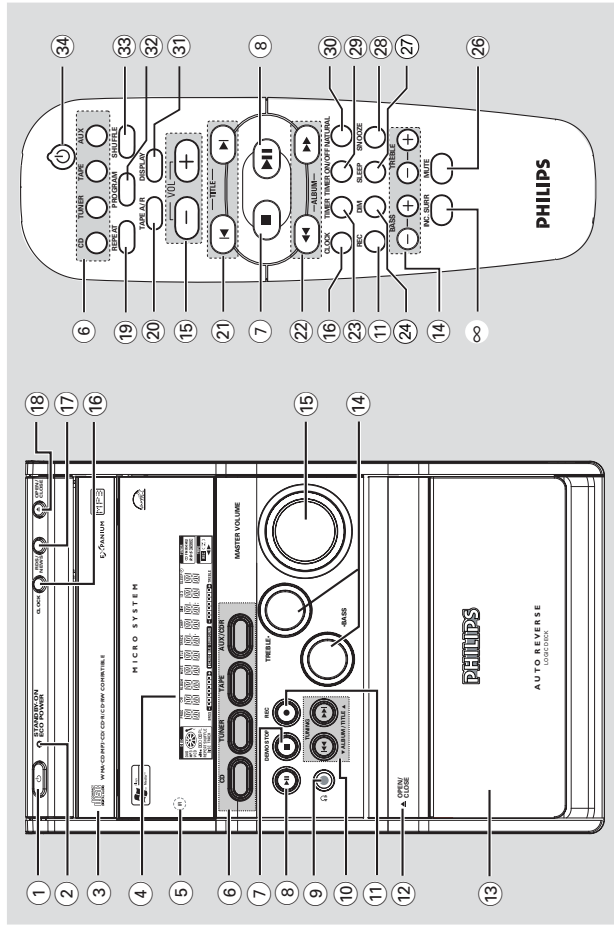

Main unit and remote control

- 1 **STANDBY ON** Switches to Eco Power standby mode or turns on the system.
 - *Switches to standby mode.
- 2 **ECO POWER indicator** Lights up when the system is in Eco Power standby mode.
- 3 **Disc tray** Selects the remote control towards this sensor.
- 4 **Display screen** Points the remote control towards this sensor.
- 5 **iR** Points the remote control towards this sensor.
- 6 **CD / TUNER / TAPE /AUX/CDR** Selects the relevant active mode.
 - CD: switches to CD mode.
 - TUNER: toggles between FM and MW band.
 - TAPE: switches to Tape mode.
 - AUX/CDR: toggles between AUX and CDR mode.

- 7 **DEMO STOP** Exits an operation.
 - CD: stops playback or clears a programme.
 - TUNER: *erases a preset radio station.
 - TAPE: stops playback or recording.
- (only on the main unit)
 - *Turns on/off the demonstration mode.
- 8 **II**
 - CD: starts/pauses playback.
 - TAPE: starts playback or selects other side of the tape during playback.
 - CLOCK: toggles between hour and minutes setting.
- (only on the main unit)
 - TUNER: *enters Plug & Play mode and/or starts preset radio station installation.
- 9 Plug in the headphones jack. The speakers output will be cancelled.

Functional Overview

- 10 **TUNING**
 - CD: *searches backward/forward or selects a track.
 - MP3/WMA: *selects an album or selects a title (track).
 - TUNER: tunes the radio frequency up/down.
 - TAPE: rewind or fast forward.
 - CLOCK: sets the hours or minutes.
 - 11 **REC**
 - *starts recording on a tape.
 - 12 **OPEN/CLOSE** Opens/closes the tape deck door.
 - 13 **Tape deck**
 - 14 **BASS/TREBLE (+ -)** Selects a desired BASS (low tone) or TREBLE (high tone) level.
 - 15 **MASTER VOLUME (VOL + -)** Adjusts the volume level.
 - 16 **CLOCK** Switches to clock display mode or enter clock setting mode.
 - 17 **RDS/NEWS**
 - In tuner mode, selects RDS information.
 - In other modes, turns on/off news.
 - 18 **OPEN/CLOSE** Opens/closes the disc tray.
- Control buttons available on the remote only**
- 19 **REPEAT** Repeats a track/disc/all programmed tracks.
 - 20 **TAPE AIR** Selects the desired tape playback modes: one side, both sides or auto replay.
 - 21
 - MP3/WMA: selects an MP3/WMA title (track).
 - CD: selects a track.
 - TUNER: selects a preset radio station.
 - TAPE: selects other side of the tape.
 - 22
 - Switches to Eco Power standby mode.
 - *Switches to standby mode.
 - 23 **TIMER** Displays the timer setting or enter timer setting mode.
 - 24 **DIM** Selects different levels of brightness for display panel.
 - ∞ **INC. SURR.** Turns on/off the incredible surround sound effect.
 - 26 **MUTE** Mutes or restores the volume.
 - SLEEP** Sets the sleep timer function.
 - 28 **SNOOZE** Temporarily deactivate the wake up timer.
 - 29 **TIMER ON/OFF** Turns on/off timer function.
 - 30 **NATURAL** Selects flat sound effect.
 - 31 **DISPLAY** Displays the album and title name for MP3/WMA disc.
 - PROGRAM**
 - CD: starts or confirms tracks programming.
 - TUNER: starts *automatic/manual preset programming.
 - CLOCK: selects 12- or 24-hour clock display.
 - 33 **SHUFFLE** Turns on/off random play mode.
 - 34
 - Switches to Eco Power standby mode.
 - *Switches to standby mode.

* = Press and hold the button for more than two seconds.

* = Press and hold the button for more than two seconds.

Troubleshooting

WARNING

Under no circumstances should you try to repair the system yourself, as this will invalidate the warranty. Do not open the system as there is a risk of electric shock.

If a fault occurs, first check the points listed below before taking the system for repair. If you are unable to remedy a problem by following these hints, consult your dealer or Philips for help.

Problem	Solution
Radio reception is poor.	<ul style="list-style-type: none">✓ If the signal is too weak, adjust the antenna or connect an external antenna for better reception.✓ Increase the distance between the system and your TV or VCR.
“NO DISC” is displayed or the disc cannot be played.	<ul style="list-style-type: none">✓ Insert a disc.✓ Load in the disc with label facing up.✓ Replace or clean the disc, see "Care and safety information".✓ Use a finalised CD-R(W) or a correct format disc.
The system does not react when buttons are pressed.	<ul style="list-style-type: none">✓ Remove and reconnect the AC power cord and switch on the system again.
Recording or playback cannot be made.	<ul style="list-style-type: none">✓ Use only NORMAL (IEC I) tape.✓ Apply a piece of adhesive tape over the missing tab space.
The tape deck door cannot open.	<ul style="list-style-type: none">✓ Remove and reconnect the AC power plug and switch on the system again.
Sound cannot be heard or is of poor quality.	<ul style="list-style-type: none">✓ Adjust the volume.✓ Disconnect the headphones.✓ Check that the speakers are connected correctly.✓ Check that the AC power cord is connected properly.
The remote control does not function properly.	<ul style="list-style-type: none">✓ Select the source (CD or TUNER, for example) before pressing the function button (▶▶, ◀◀, ▶▶▶).✓ Reduce the distance between the remote control and the system.✓ Replace the battery.✓ Point the remote control directly toward the IR sensor.
The timer is not working.	<ul style="list-style-type: none">✓ Set the clock correctly.✓ Press TIMER ON/OFF to switch on the timer.✓ If recording is in progress, stop the recording.
The system displays features automatically and buttons start flashing.	<ul style="list-style-type: none">✓ Press and hold DEMO STOP on the main unit to switch off the demonstration mode.

DISMANTLING INSTRUCTIONS

Dismantling of the Cover Cassette and Universal Loader

- 1) Remove the Cover Cassette (pos 150) in the direction as shown in Figure 1.
- 2) Loosen 4 screws to remove the Cover Top (pos 240) by sliding it out towards the rear before lifting up.
 - 2 screws on the rear
 - 1 screw each on the left & right side
- 3) Loosen 2 screws each to remove the Panel Left (pos 180) and Panel Right (pos 181). The Panels are removed by sliding it towards the rear and outwards.
 - 1 screw on the rear
 - 1 screw on the side
 - see Service position A
- 4) Use a screw driver to give a push in the direction as shown in Figure 2 and Figure 2A to unlock the Loader Tray before sliding it out.
- 5) Slide out the Loader Tray and remove the Cover CD (pos 110 + pos 111) in the direction as shown in Figure 3.
- 6) Loosen 4 screws A (see Figure 4) to remove the Bracket Module Mounting (pos 156) and Universal Loader (pos 1103).
 - 2 screws each on the left & right side

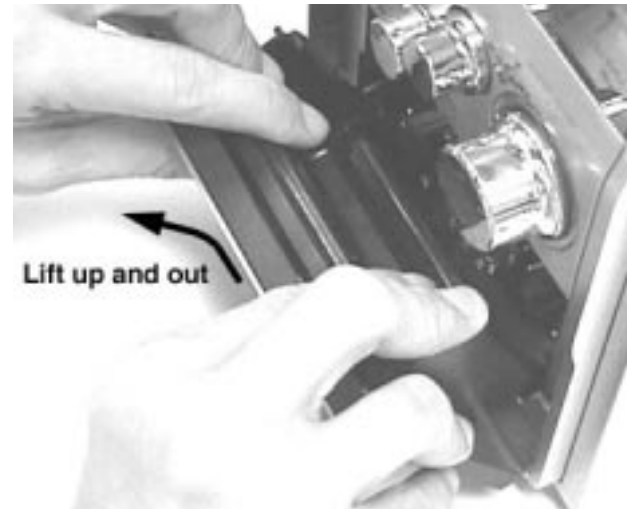

Figure 1

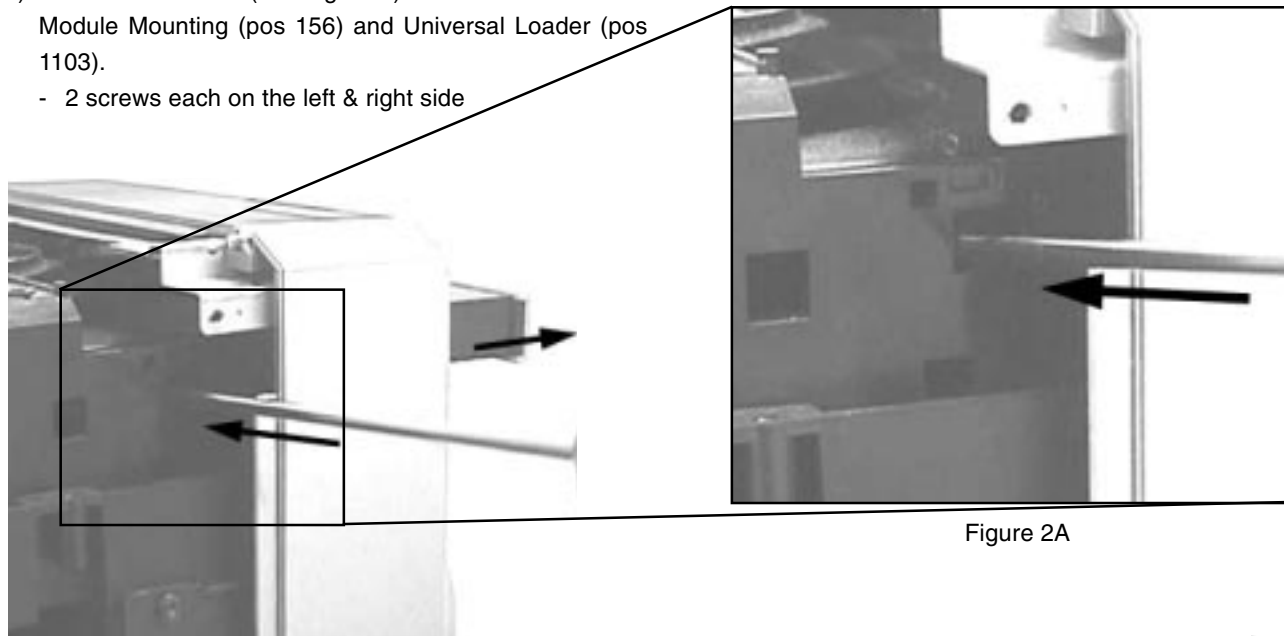

Figure 2A

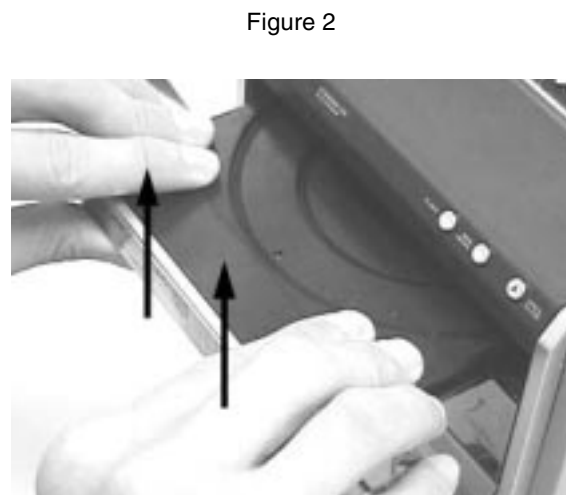

Figure 3

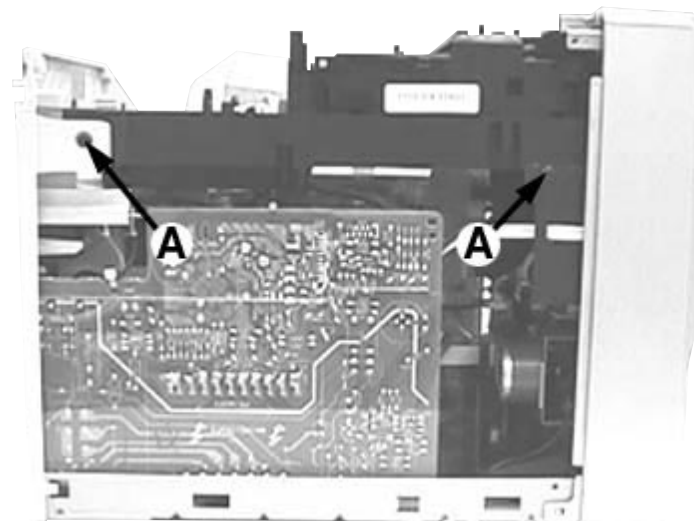

Figure 4

Detaching the Universal Loader from the Bracket Module Mounting

- 1) Slide out the Loader Tray fully and remove 4 screws B (see Figure 5) to detach the Universal Loader (pos 1103) from the Bracket Module Mounting (pos 156).
 - see Service position B

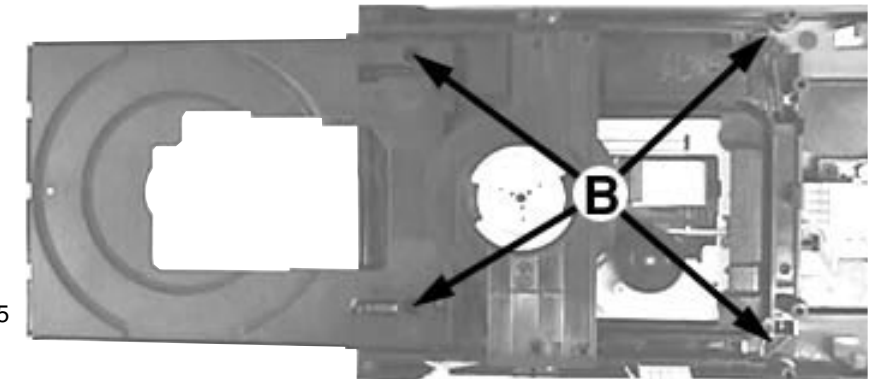

Figure 5

Detaching the Front Panel assembly from the Bottom/Rear assembly

- 1) Remove 2 screws C (see Figure 6) from the bottom of the Cabinet Front (pos 101).
- 2) Release the fixation of the Combi Board (pos 1102-1003) to Bracket Combi (pos 155) by releasing the 2 catches C1 (see Figure 7) and pulling the Combi Board outwards as shown in Figure 7A.
- 3) Uncatch 2 catches C2 (see Figure 7) on the left & right sides of the Cabinet Front (pos 101) and slides the Front Panel assembly out towards the front.
 - see Service position C

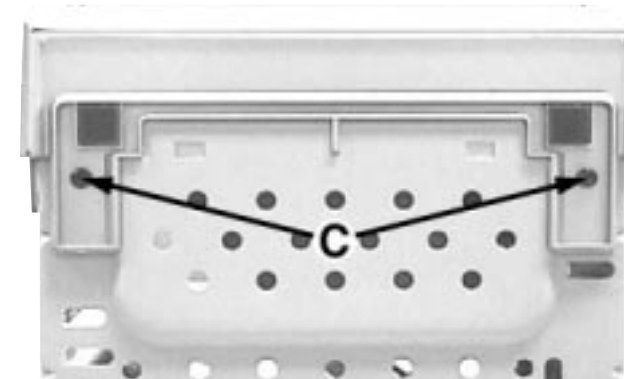

Figure 6

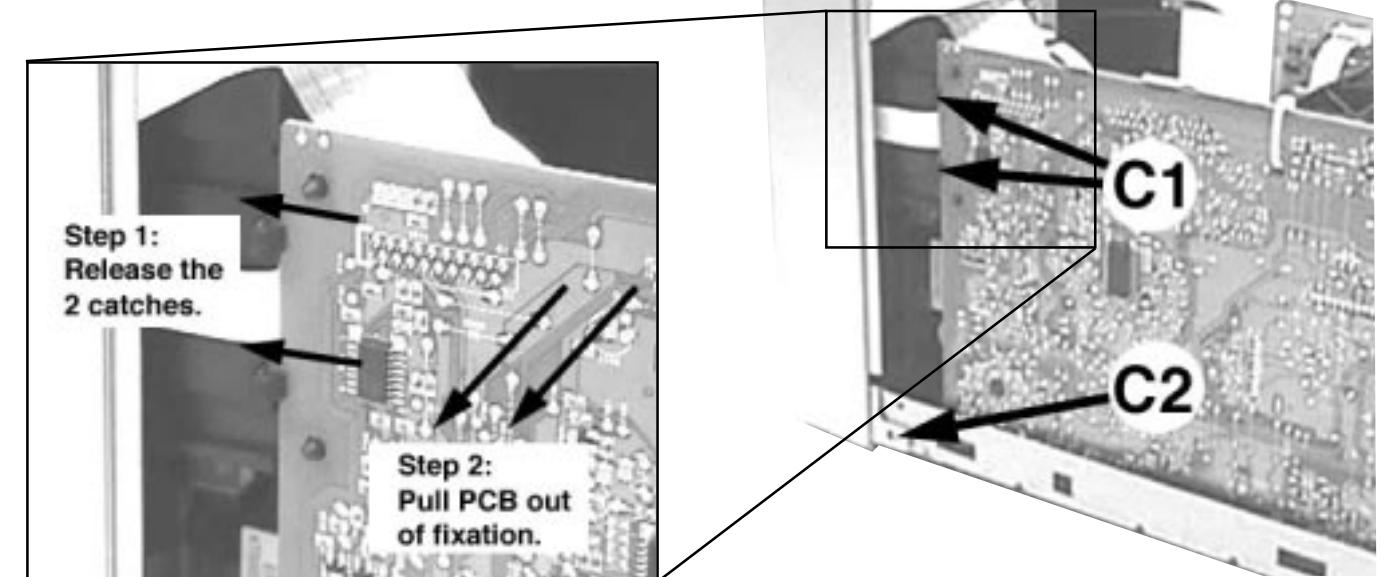

Figure 7A

Figure 7

DISMANTLING INSTRUCTIONS

Dismantling of the Front Panel assembly

- 1) The Knob Volume (pos 141) can be removed by pulling it out in the direction as shown in Figure 8.
- 2) The Knob Bass/Knob Treble (pos 140) can be removed by pulling it out in the direction as shown in Figure 9.
- 3) Loosen 4 screws D (see Figure 12) to remove the Shield Tape Deck and Module Tape Deck (pos 1107).
- 4) Loosen 2 screws E (see Figure 11) to remove the Bracket Top Support (pos 113).



Figure 8



Figure 9

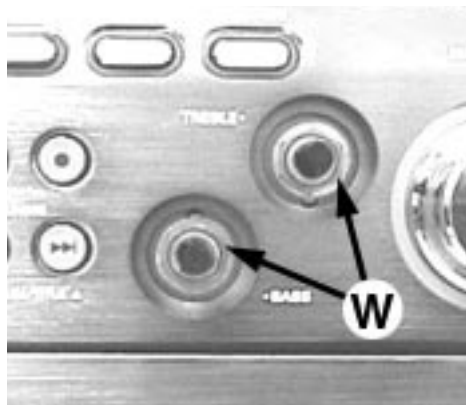

Figure 10

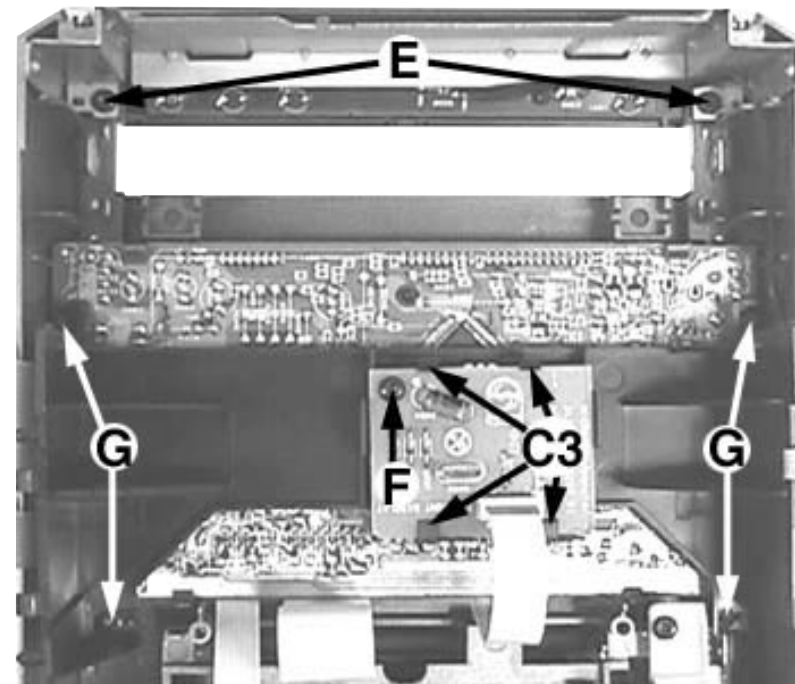

Figure 11

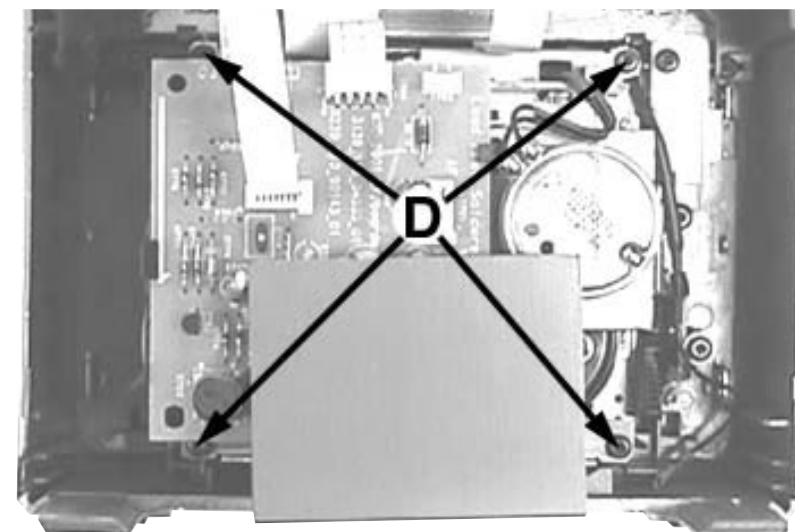

Figure 12

- 5) Loosen 1 screw F and 4 catches C3 (see Figure 11) to remove the Eeprom Board (pos 1105D).
- 6) Loosen 4 screws G (see Figure 11) to remove the Bracket Combi (pos 155).
- 7) Uncatch 4 catches C4 (see Figure 13) to remove the Display Board (pos 1105A).
- 8) Loosen 4 screws H (see Figure 13) to remove the Top Key Board (pos 1105C).
- 9) Loosen 5 screws J (see Figure 14) and 2 nuts W (see Figure 10) to remove the Control Board (pos 1105B).

Dismantling of the Front Panel assembly

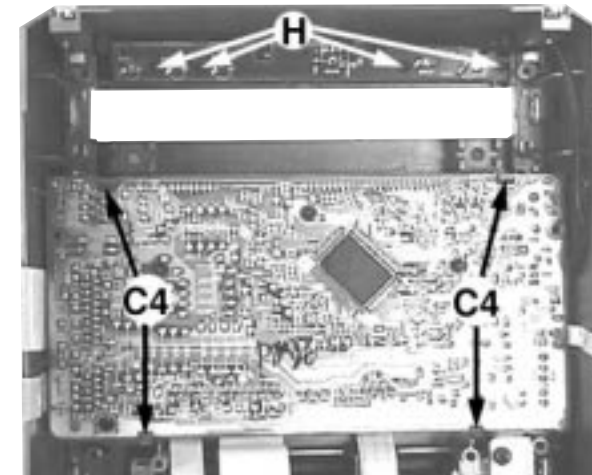

Figure 13

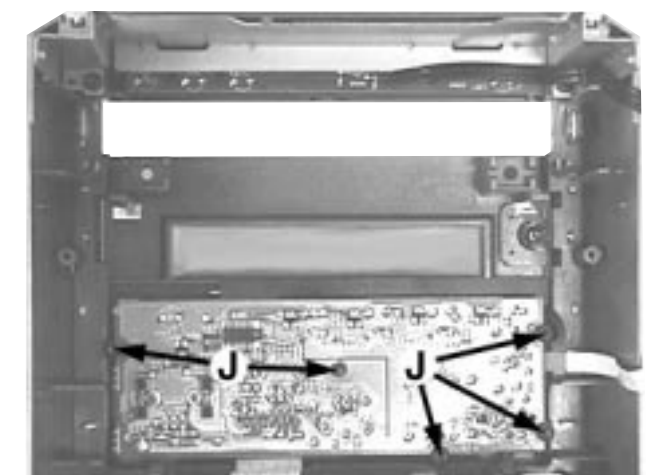

Figure 14

Dismantling of the Rear Panel assembly

- 1) Loosen 3 screws K and 2 catches C5 (see Figure 15) to remove the Tuner Board assembly.
- 2) Loosen 3 screws L (see Figure 15) to free the Combi Board (pos 1102-1003).
- 3) Loosen 1 screw M (see Figure 15) to free the Mains Socket Board (pos 1102-1001B).

- 4) Loosen 1 screw N and 2 catches C6 (see Figure 15) to free the Panel Rear (pos 230) by sliding it out towards the rear.

Note : Tuner Board assembly and Mains Socket Board can also be removed together with the Panel Rear.

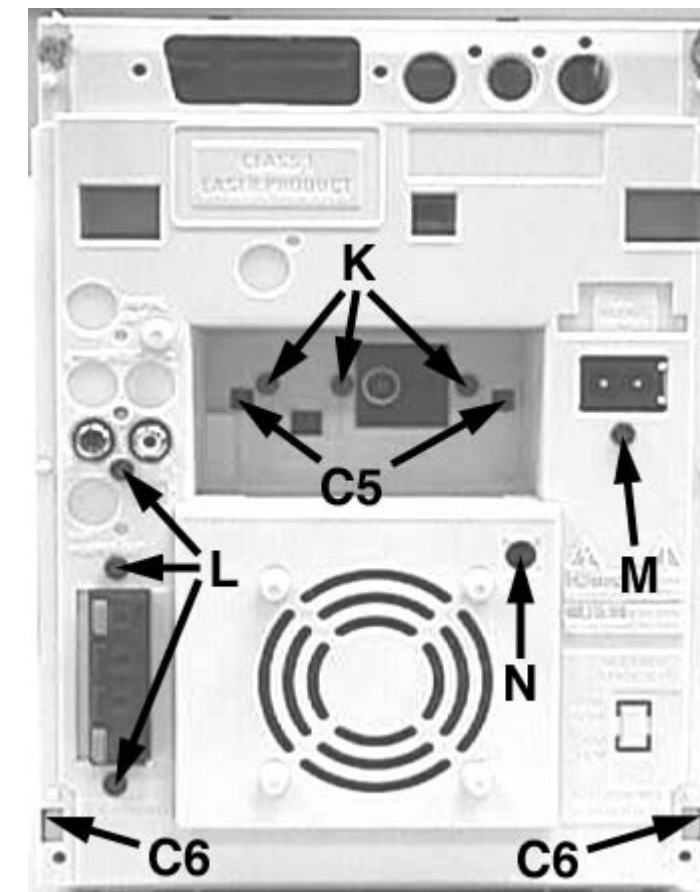

Figure 15

DISMANTLING INSTRUCTIONS

Repair Hints & Service Positions

- 1) During repair it is possible to disconnect the Tuner Board and/or CD Module completely unless the fault is suspected to be in that area. This will not affect the performance of the rest of the set.

Note: The flex cables are very fragile, care should be taken not to damage them during repair. After repair, be very sure that the flex cables are inserted properly into the flex sockets before encasing, otherwise faults may occur.

Service position A

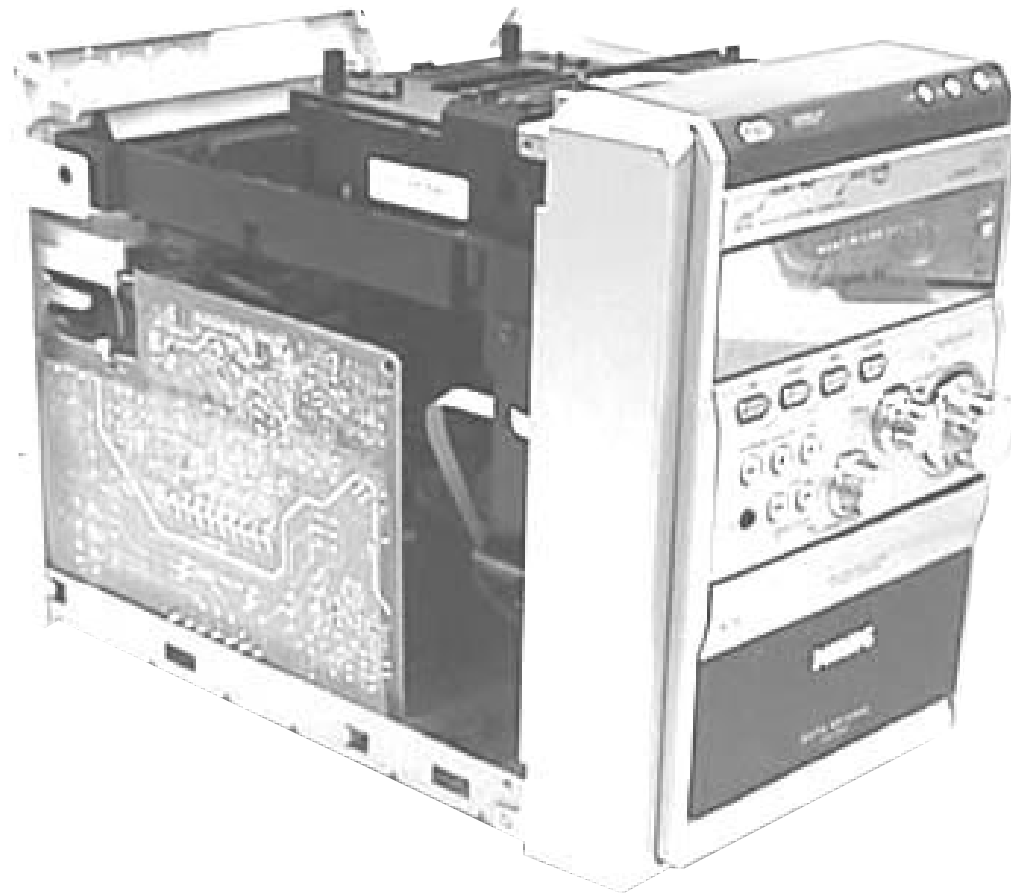

Service position B

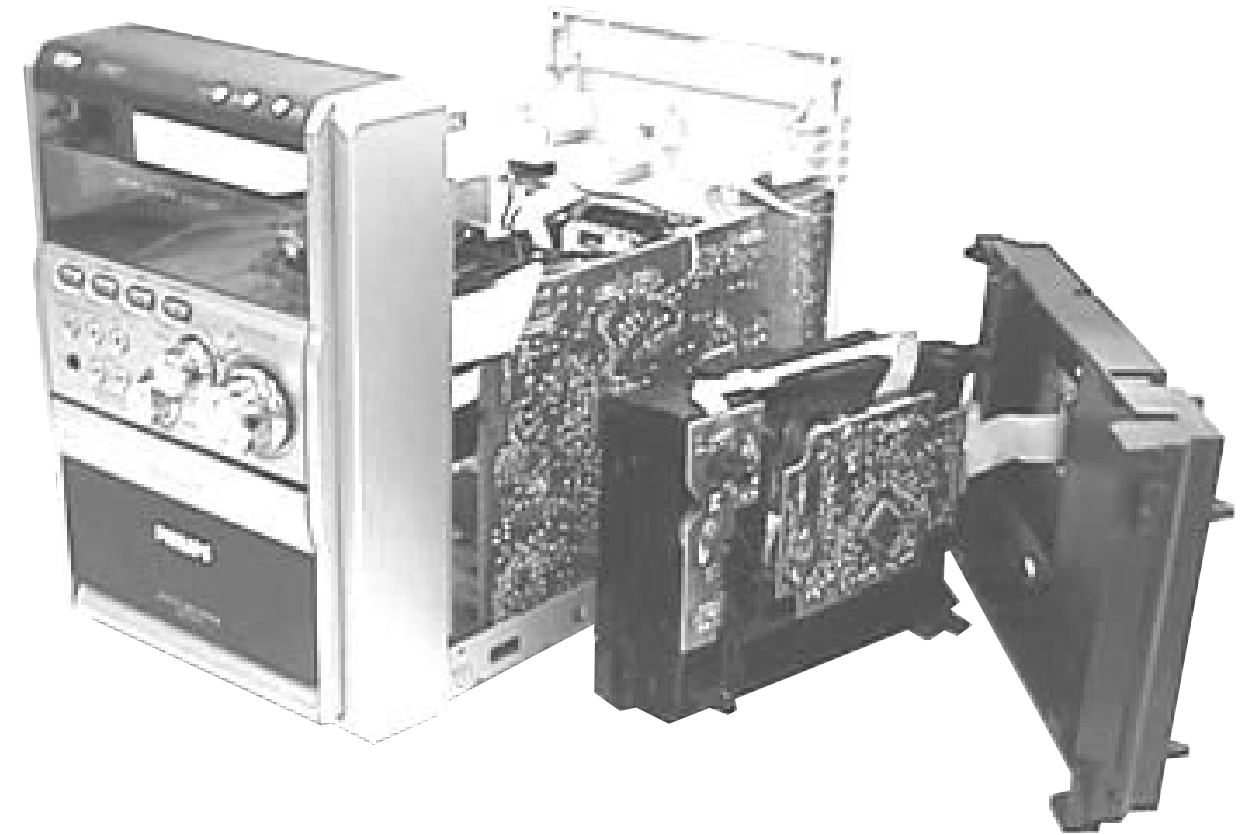

Service position C

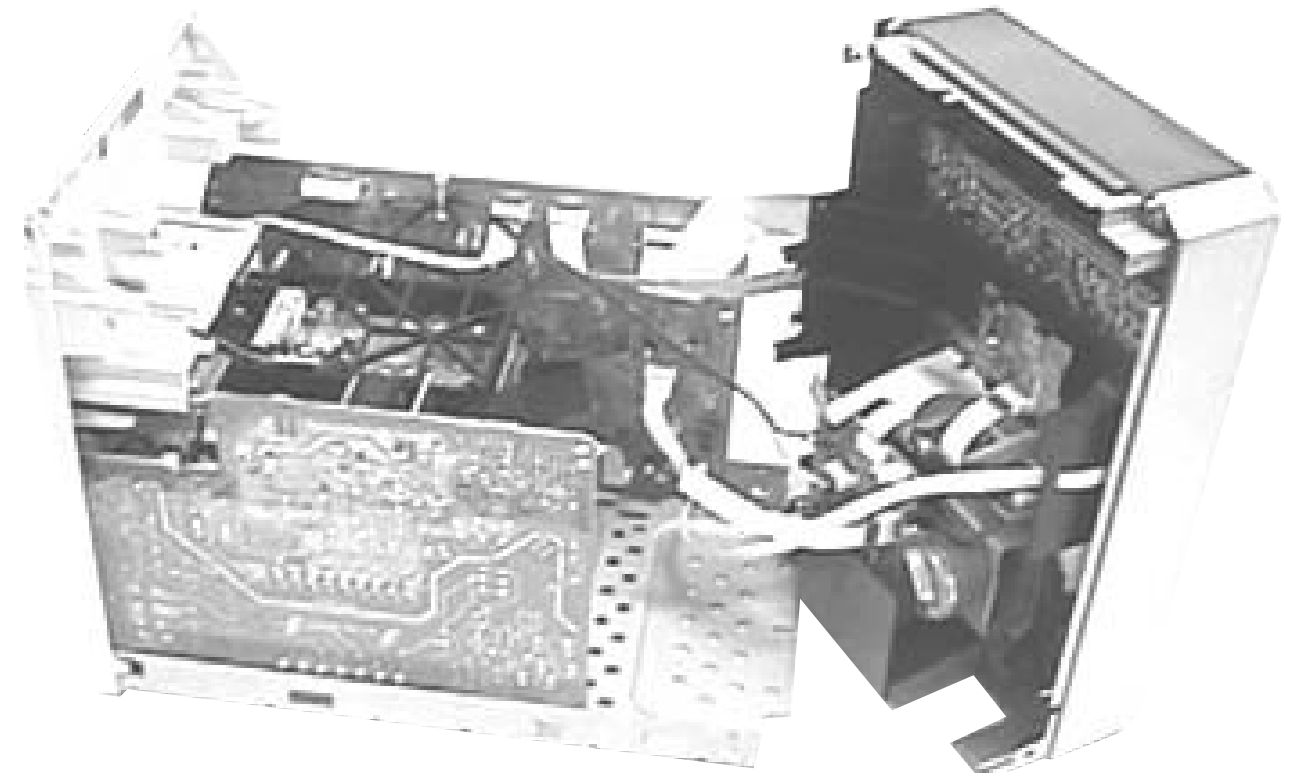

SERVICE TEST PROGRAM

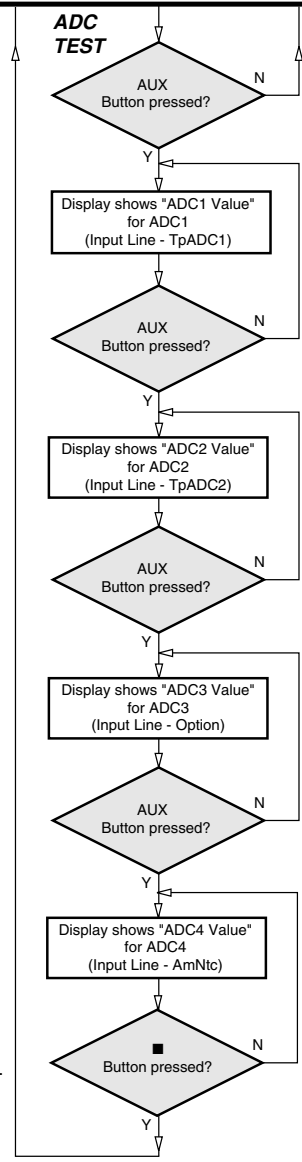
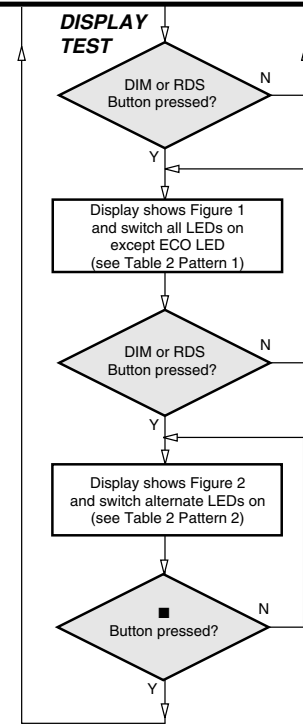
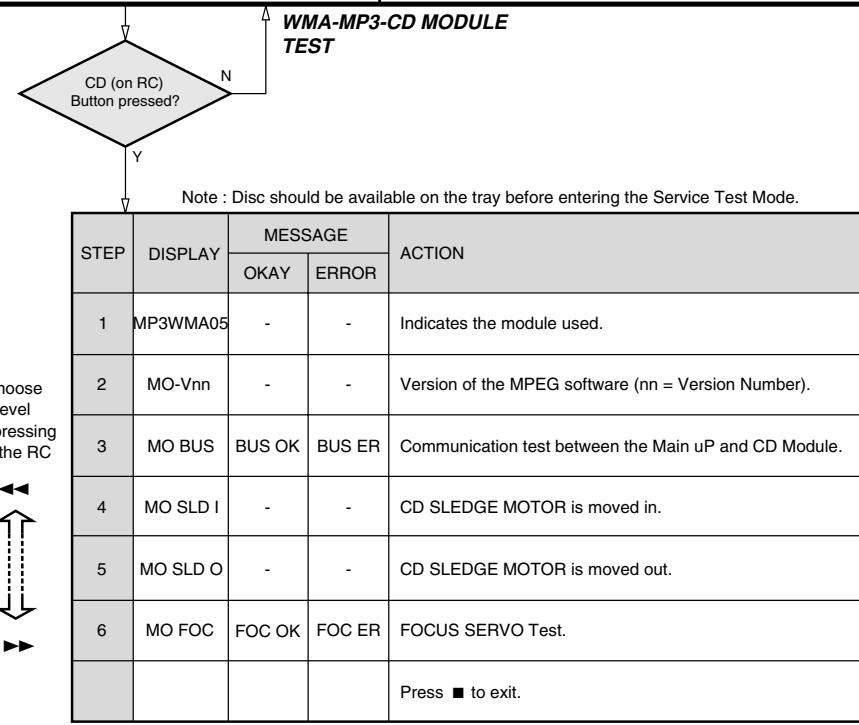
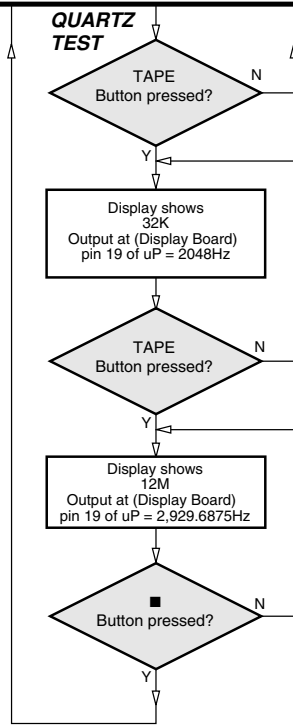
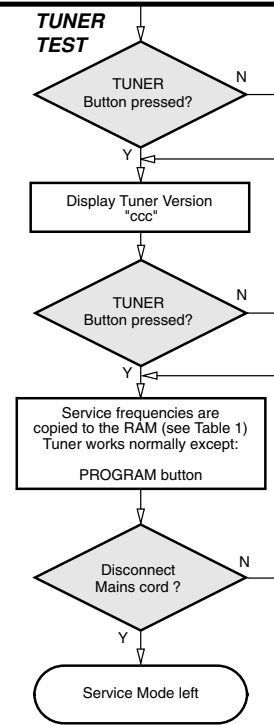
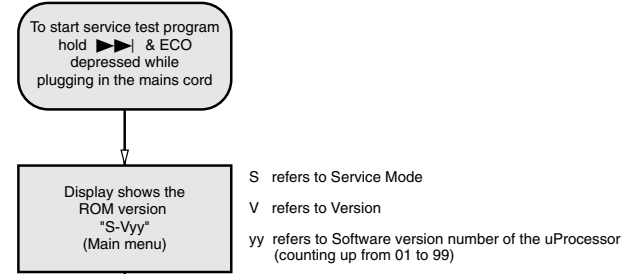

PRESET	Europe "EUR"	East Europe "EAS"	East Eur. Extended-band "EAS"	USA "USA"	Oversea "OSE"
1	87.5MHz	87.5MHz	65.81MHz	87.5MHz	87.5MHz
2	108MHz	108MHz	108MHz	108MHz	108MHz
3	531kHz	531kHz	74MHz	530kHz	531/530kHz*
4	1602kHz	1602kHz	87.5MHz	1700kHz	1602/1700kHz*
5	558kHz	558kHz	531kHz	560kHz	558/560kHz*
6	1494kHz	1494kHz	1602kHz	1500kHz	1494/1500kHz*
7	87.5MHz	87.5MHz	558kHz	98MHz	87.5/98MHz*
8	87.5MHz	87.5MHz	1494kHz	87.5MHz	87.5MHz
9	87.5MHz	87.5MHz	98MHz	87.5MHz	87.5MHz
10	87.5MHz	87.5MHz	70.01MHz	87.5MHz	87.5MHz
11	98MHz	98MHz	65.81MHz	87.5MHz	98/87.5MHz*

Table 1

Note: * Depending on the selected grid frequency (9 or 10kHz).
 By holding the ECO and TUNER buttons depressed while switching on the Mains supply, one of the undermentioned features will be activated:
 - the tuning grid frequency is toggled between 9kHz and 10kHz for the Oversea (/21) version.
 - the extended FM1 (65.81MHz - 74MHz) is toggled on and off for East Eur. (/34) version.

LEDs	Pattern 1	Pattern 2
ECO	Off	Off
CD	On	On
TUNER	On	Off
TAPE	On	On
AUX	On	Off
Volume Rotary	On	On

Table 2



Figure 1

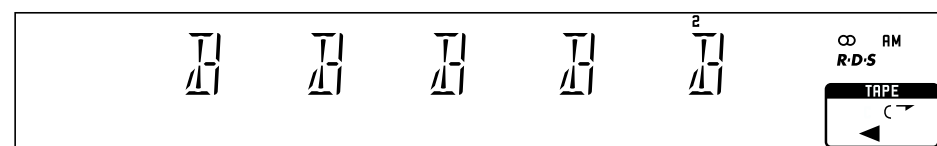
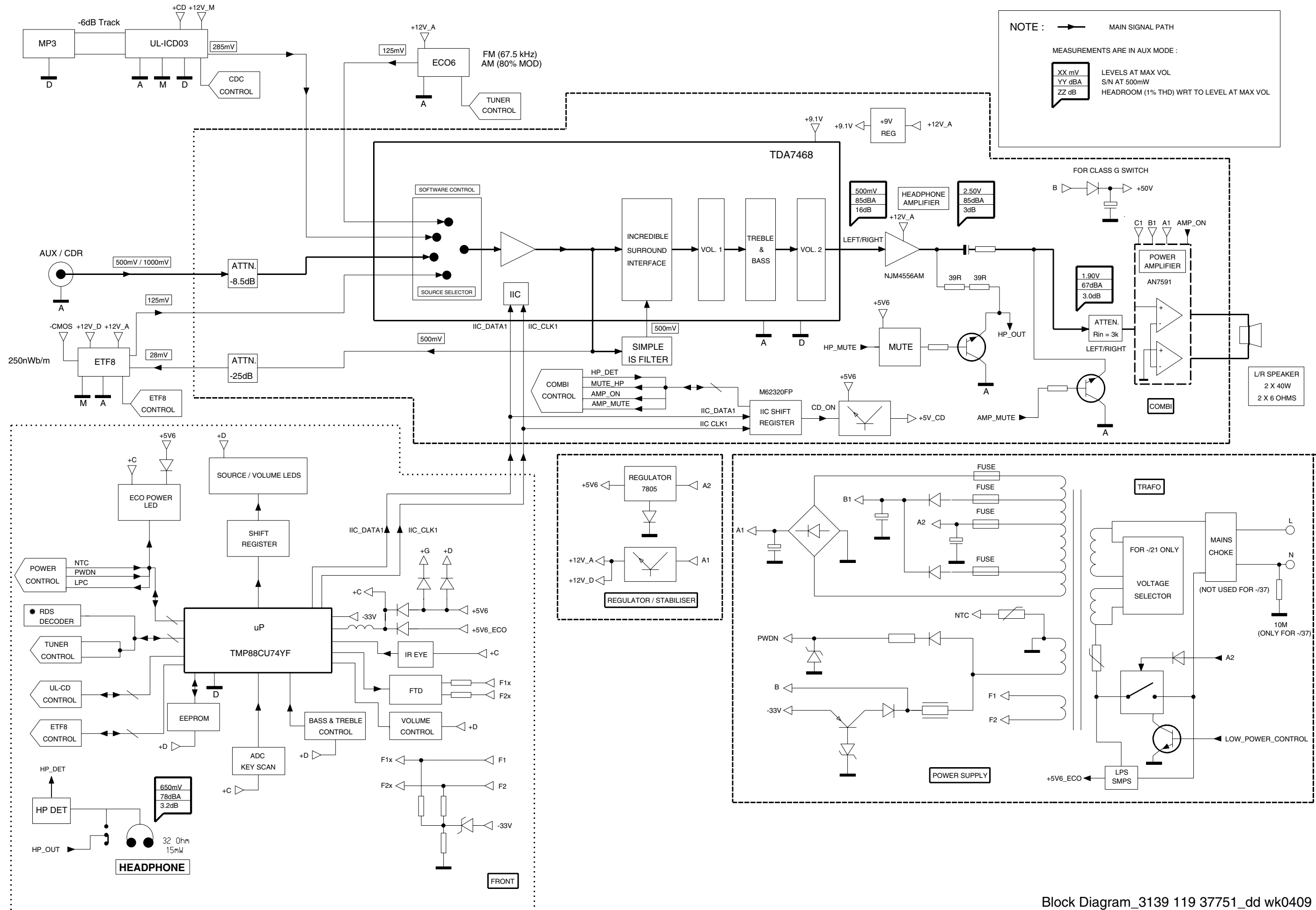

Figure 2

ADC Test is used for checking the ADC inputs to the microprocessor.
 The display shows an ADC value between 0 and 255 for an input signal between 0 and 5V.

TEST	Activated with	ACTION
EEPROM TEST	[TUNER] to Exit	Test patterns will be sent to the EEPROM. "PASS" is displayed if the uProcessor read back the test patterns correctly, otherwise "FAIL" will be displayed.
EEPROM FORMAT TEST	[TUNER]	Load default data. Display shows "NEW" for 1 second. Caution! All presets from the customer will be lost!!
DEMO TOGGLE	[TUNER]	Pressing this button will toggle between DEMO ON and DEMO OFF. The DEMO status will scroll once across the Display.
ROTARY ENCODER TEST	Volume, Treble or Bass Knob	Display shows value for 2 seconds. Values increases or decreases until Volume Maximum (0dB) or Volume Minimum (VOL MUTE) is reached.
LEAVE SERVICE TEST PROGRAM	Disconnect mains cord	

SET BLOCK DIAGRAM



SET WIRING DIAGRAM

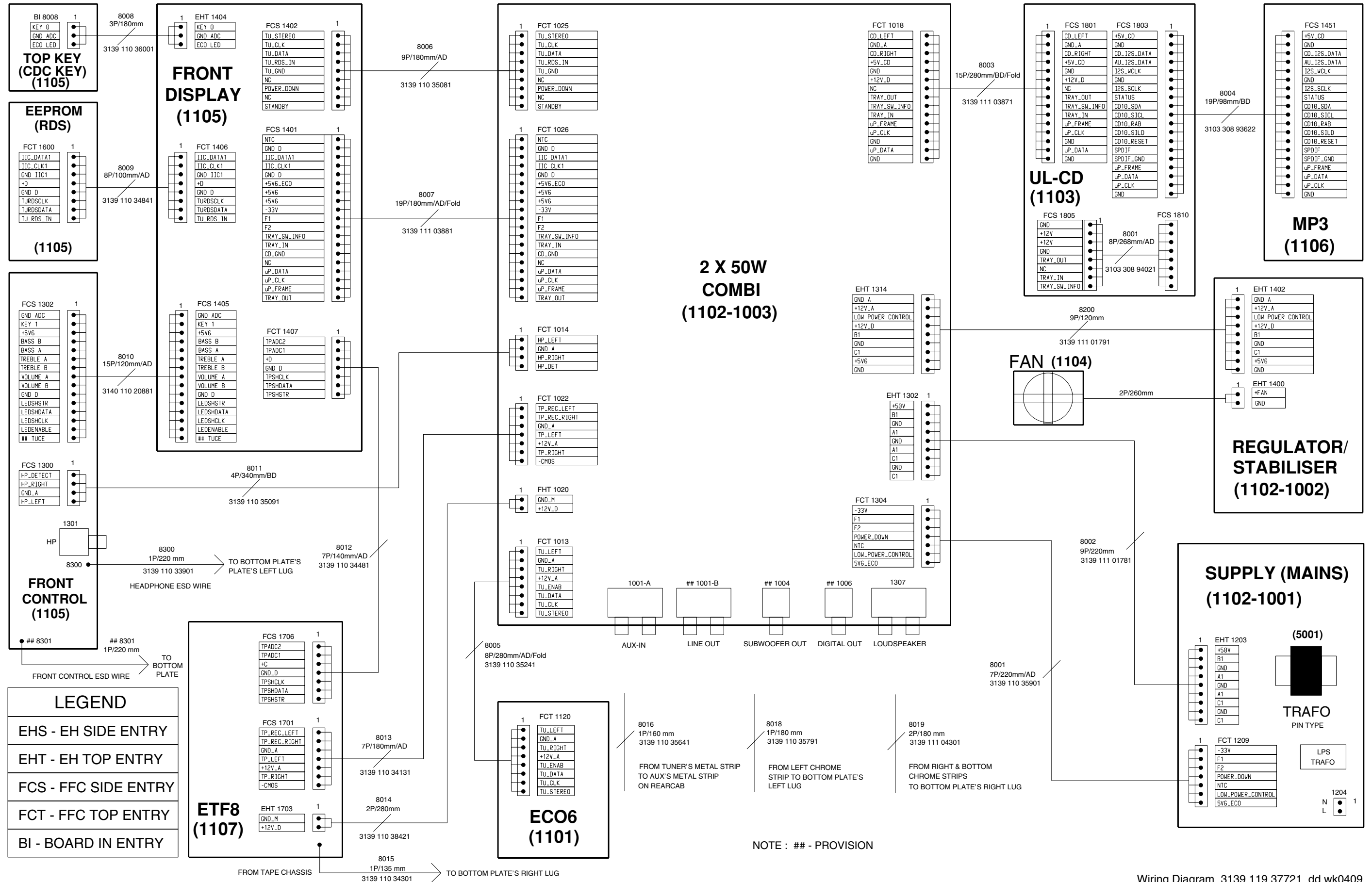

FRONT BOARD

TABLE OF CONTENTS

FTD Display Pin Connection	6-2
Display part - Component Layout	6-3
Display part - Chip Layout	6-4
Display part - Circuit Diagram Part 1	6-5
Display part - Circuit Diagram Part 2	6-6
Display part - Variant Table	6-7
Top Key part - Layout & Circuit diagram	6-7
Control part - Component & Chip Layout	6-8
Control part - Circuit Diagram Part 1	6-9
Control part - Circuit Diagram Part 2	6-10
Eeprom part - Layout & Circuit diagram	6-11
Karaoke part - Component & Chip Layout	6-12
Karaoke part - Circuit Diagram	6-13
Electrical parts list	6-14

DISPLAY BOARD - COMPONENT LAYOUT

1400 A4	2405 A5	2473 A1	3520 A1	5404 B5	6404 A5	9400 B6	9420 A2	9428 B1	9436 C2	9444 C4	9452 B5	9460 B5
1401 A6	2450 A2	3420 A6	3521 A6	5405 A5	6405 A2	9401 C2	9421 A3	9429 B1	9437 C2	9445 C4	9453 C6	9461 B6
1402 B6	2453 A2	3433 B2	3522 A6	5406 A5	6406 A2	9402 A3	9422 A2	9430 B1	9438 C3	9446 A5	9454 B5	9462 B6
1404 A1	2457 C2	3434 B1	3523 A6	5407 B1	6407 B2	9403 A4	9423 A2	9431 C1	9439 A4	9447 A5	9455 B5	9463 B6
1405 C5	2461 A1	3497 C3	3524 A6	6400 B1	6408 A1	9404 B6	9424 A2	9432 C1	9440 B3	9448 A6	9456 B5	9464 B6
1406 C3	2462 A1	3512 C6	3535 B2	6401 A5	6409 A6	9405 B5	9425 B1	9433 C1	9441 C3	9449 A5	9457 B5	9465 B6
1407 C6	2463 A6	3518 A6	5400 A4	6402 A5	6410 A6	9406 B2	9426 B2	9434 C1	9442 C3	9450 A5	9458 B5	9466 B5
2404 A4	2464 A6	3519 A1	5401 B4	6403 A5	7403 A1	9407 B1	9427 A2	9435 C1	9443 C4	9451 B5	9459 B5	

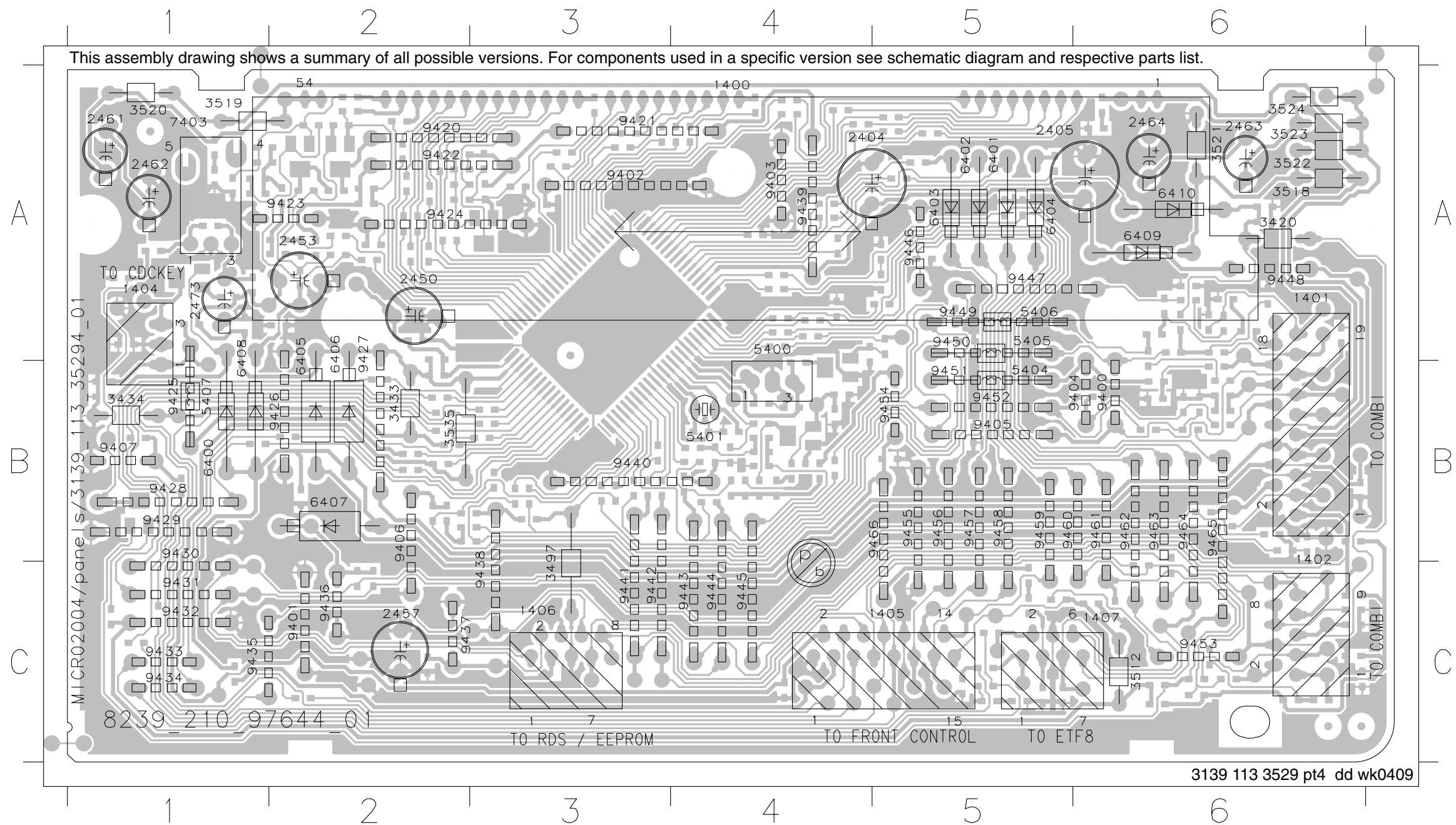

DISPLAY BOARD - CHIP LAYOUT

2400	C2	2423	C2	2459	C1	3402	A5	3422	A3	3443	B4	3462	B4	3481	A4	3501	B1	3529	A5	4410	B5	4431	A5	4451	C1
2401	B3	2424	C2	2460	C1	3403	B3	3423	A3	3444	B4	3463	B5	3482	A4	3502	B1	3531	A5	4411	A1	4432	A5	4452	A5
2402	B3	2425	A2	2465	A6	3404	B3	3424	A2	3445	B6	3464	B5	3483	A4	3503	B1	3532	A6	4412	A1	4433	A5	4453	A5
2403	B3	2426	A2	2466	A6	3405	B3	3425	A3	3446	B4	3465	A6	3484	A4	3504	B1	3533	A6	4413	A1	4434	A6	4454	C2
2406	B3	2440	B1	2467	A1	3406	B3	3426	A3	3447	B4	3466	A5	3485	A3	3505	B1	3534	A6	4415	C1	4436	C5	4455	B2
2407	A3	2441	B1	2468	A1	3407	A3	3427	A3	3448	B4	3467	A5	3486	A3	3506	A1	3535	C6	4416	B3	4437	C6	4456	C1
2408	B3	2442	B1	2469	A2	3408	A2	3428	A3	3449	B5	3468	A5	3487	A3	3507	A1	3537	B6	4417	C1	4438	B4	4457	B3
2409	B3	2443	B1	2470	C1	3409	A3	3429	B1	3450	B5	3469	A5	3488	A3	3508	B3	3538	B6	4418	B5	4439	A4	4458	C6
2410	B3	2444	B1	2471	A3	3410	A2	3430	C1	3451	B5	3470	A5	3489	A3	3509	C1	3539	A2	4419	B1	4440	A2	4459	B1
2411	B3	2445	A1	2472	C1	3411	A3	3431	A3	3452	B4	3471	A5	3490	A4	3510	C1	4400	B3	4420	C6	4441	A2	5402	B5
2412	B6	2446	B1	2474	A6	3412	A2	3432	A2	3453	B5	3472	A5	3491	A6	3511	C1	4401	A5	4421	B1	4442	A2	5403	A5
2413	A5	2447	A1	2476	A6	3413	A3	3435	B3	3454	B5	3473	A5	3492	A5	3513	C1	4402	A5	4422	B1	4443	A1	7400	A4
2414	A4	2448	A1	2477	A4	3414	A3	3436	B3	3455	B5	3474	A5	3493	A6	3514	C1	4403	A5	4423	A1	4444	B3	7401	A6
2415	A5	2449	B1	2478	A5	3415	A3	3437	B3	3456	B5	3475	A5	3494	C5	3515	C1	4404	C5	4424	A1	4445	B3	7402	B3
2416	A5	2451	A5	2479	A6	3416	A3	3438	B3	3457	B5	3476	A5	3495	C5	3516	C2	4405	A1	4426	A1	4446	B3	7404	B3
2417	A5	2452	B5	2480	C3	3417	A2	3439	B3	3458	B4	3477	A5	3496	A2	3517	B3	4406	B1	4427	B1	4447	C2	7405	A4
2418	A5	2454	A6	2481	A1	3418	A2	3440	B4	3459	B5	3478	A5	3498	C2	3525	A1	4407	B1	4428	A1	4448	C2	7406	B6
2419	A5	2456	B2	3400	A6	3419	A3	3441	B4	3460	B4	3479	A4	3499	C2	3526	A5	4408	A1	4429	C1	4449	C2	7407	A5
2420	A6	2458	C2	3401	B6	3421	A1	3442	B4	3461	B5	3480	A4	3500	B1	3527	A4	4409	A1	4430	A5	4450	C1	7408	A5

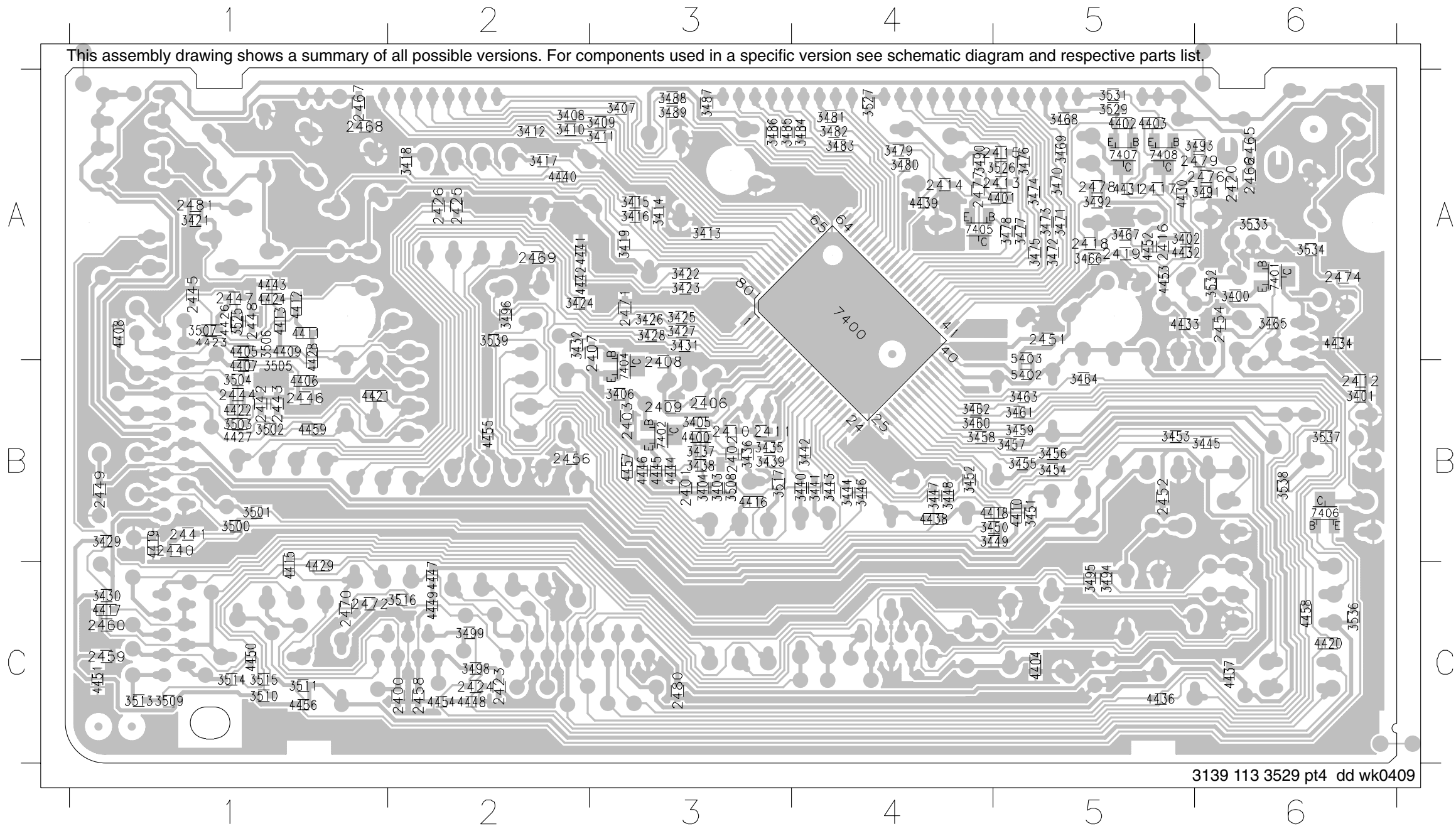

DISPLAY BOARD - CIRCUIT DIAGRAM PART 1

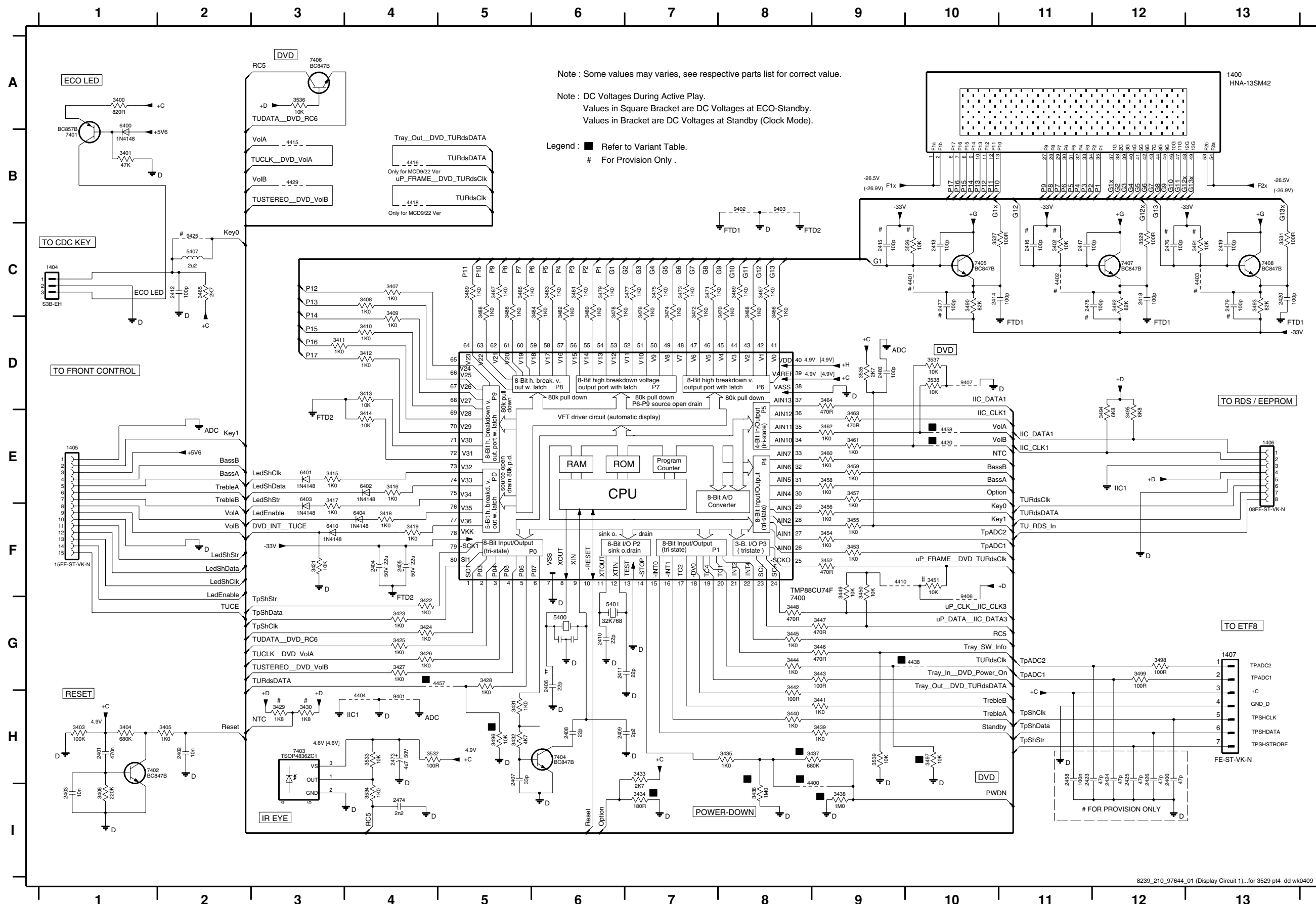

Note : Some values may varies, see respective parts list for correct value.

Note : DC Voltages During Active Play.
Values in Square Bracket are DC Voltages at ECO-Standby.
Values in Bracket are DC Voltages at Standby (Clock Mode).

Legend : ■ Refer to Variant Table.
For Provision Only .

- 1400 A13
- 1404 C1
- 1405 E1
- 1406 E13
- 1407 G13
- 2400 H12
- 2401 H1
- 2402 H2
- 2403 I1
- 2404 F4
- 2405 F4
- 2406 G6
- 2407 H5
- 2408 H6
- 2409 H6
- 2410 G6
- 2411 G6
- 2412 C2
- 2413 C10
- 2414 C10
- 2415 C9
- 2416 C11
- 2417 C11
- 2418 C12
- 2419 C13
- 2420 C13
- 2423 H11
- 2424 H12
- 2425 H12
- 2426 H12
- 2458 H11
- 2473 H4
- 2474 I4
- 2476 C12
- 2477 C10
- 2478 C11
- 2479 C13
- 2480 D9
- 3400 A1
- 3401 B1
- 3402 C11
- 3403 H1
- 3404 H11
- 3405 H2
- 3406 I1
- 3407 C4
- 3408 C4
- 3409 C4
- 3410 D4
- 3411 D3
- 3412 D4
- 3413 D4
- 3414 E4
- 3415 E3
- 3416 E4
- 3417 E3
- 3418 F4
- 3419 F4
- 3421 F3
- 3422 G4
- 3423 G4
- 3424 G4
- 3425 G4
- 3426 G4
- 3427 G4
- 3428 G5
- 3429 H3
- 3430 H3
- 3431 H5
- 3432 H5
- 3433 H7
- 3434 F7
- 3435 H8
- 3436 I8
- 3437 H9
- 3438 I9
- 3439 H9
- 3440 H8
- 3441 H9
- 3442 G8
- 3443 G9
- 3444 G8
- 3445 G8
- 3446 G9
- 3448 G8
- 3449 F9
- 3450 F9
- 3451 F10
- 3452 F9
- 3453 F9
- 3454 F9
- 3455 F9
- 3456 F9
- 3457 E9
- 3458 E9
- 3459 E9
- 3460 E9
- 3461 E9
- 3462 E9
- 3463 E9
- 3464 D9
- 3465 C2
- 3466 C8
- 3467 C8
- 3468 C8
- 3469 C8
- 3470 C8
- 3471 C7
- 3472 C7
- 3473 C7
- 3474 C7
- 3475 C7
- 3476 C7
- 3477 C7
- 3478 C6
- 3479 C6
- 3480 C6
- 3481 C6
- 3482 C6
- 3483 C6
- 3484 C6
- 3485 C5
- 3486 C5
- 3487 C5
- 3488 C5
- 3489 C5
- 3490 C10
- 3491 C13
- 3492 C12
- 3493 C13
- 3494 E12
- 3495 E12
- 3496 H5
- 3497 H10
- 3498 G12
- 3499 G12
- 3526 C10
- 3527 C10
- 3528 C12
- 3529 C12
- 3531 C13
- 3532 H4
- 3533 H4
- 3534 I4
- 3535 D9
- 3536 A3
- 3537 D10
- 3538 D10
- 3539 H9
- 4400 I9
- 4401 C10
- 4402 C11
- 4403 C13
- 4404 H4
- 4410 F9
- 4415 B3
- 4416 B4
- 4418 B4
- 4420 E10
- 4429 B3
- 4438 G10
- 4457 G5
- 4458 E10
- 5400 G6
- 5401 G6
- 5407 C2
- 6400 A1
- 6401 E3
- 6402 E4
- 6403 E3
- 6404 F4
- 6410 F3
- 7400 G8
- 7401 B1
- 7402 H1
- 7403 H3
- 7404 H6
- 7405 C10
- 7406 A3
- 7407 C12
- 7408 C13
- 9401 H4
- 9402 B8
- 9403 B8
- 9404 G10
- 9405 G10
- 9406 G10
- 9407 D10
- 9425 C2

DISPLAY BOARD - CIRCUIT DIAGRAM PART 2

1401 A3	2442 C6	2446 D4	2450 F3	2454 F3	2460 C9	2464 F10	2468 F10	2472 C9	3501 B5	3505 D4	3509 B8	3513 B10	3517 C8	3521 F9	3525 D6	4408 C4	4413 E6	4422 C5	4427 C5	5403 F3	6405 E2	6409 G8	9449 D6
1402 B11	2443 C5	2447 D5	2451 F3	2456 F3	2461 E10	2465 E10	2469 C8	2481 C7	3502 B6	3506 D4	3510 B8	3514 B9	3518 E9	3522 F8	4405 D4	4409 D5	4417 C10	4423 D4	4428 D5	5404 C6	6406 F2	9400 C6	9450 D6
2440 B5	2444 C5	2448 D5	2452 F2	2457 F5	2462 E10	2466 E10	2470 C8	3420 C8	3503 C5	3507 D4	3511 B9	3515 B10	3519 D9	3523 F9	4406 D5	4411 D5	4419 A4	4424 D6	4459 C4	5405 D6	6407 E4	9404 C6	9451 D6
2441 B6	2445 D4	2449 F2	2453 F2	2459 F5	2463 F10	2467 F10	2471 C9	3500 B5	3504 C4	3508 B8	3512 B9	3516 B9	3520 E9	3524 F9	4407 C4	4412 D5	4421 C6	4426 E6	5402 E3	5406 D6	6408 F4	9405 B6	9453 B9

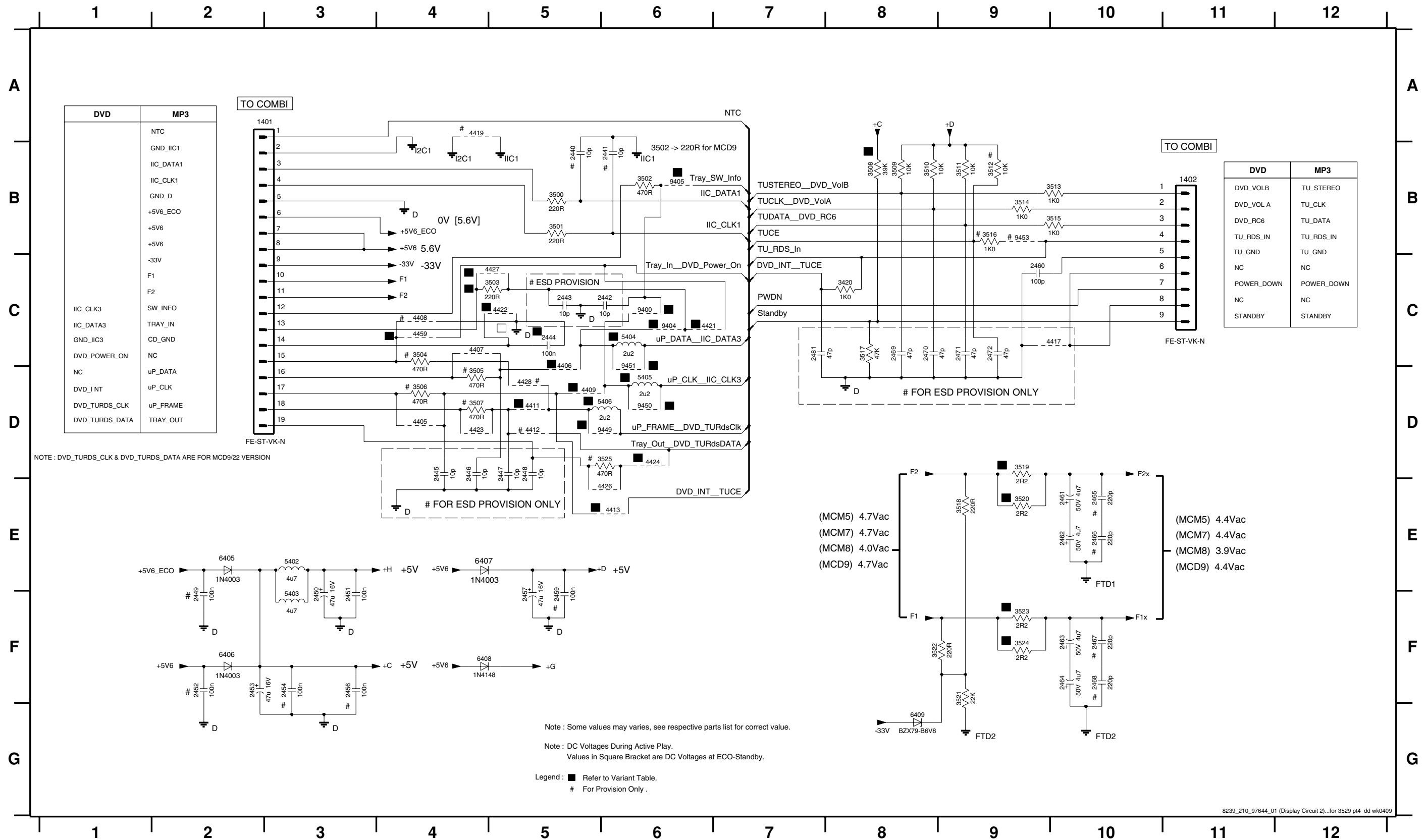

NOTE : DVD_TURDS_CLK & DVD_TURDS_DATA ARE FOR MCD9/22 VERSION

Note : Some values may varies, see respective parts list for correct value.

Note : DC Voltages During Active Play.
Values in Square Bracket are DC Voltages at ECO-Standby.

Legend : ■ Refer to Variant Table.
For Provision Only .

DISPLAY BOARD - VARIANT TABLE

	MCM9/22 MCM9/25	MCM9/37	MCM11/22 MCM11/25	MCM11/21
2444	100N	100N	100N	100N
3434	180R	180R	470R	470R
3436	1M	1M	2M2	2M2
3437	680K	680K	-	-
3438	1M	1M	-	-
3496	-	10K	-	10K
3497	-	10K	-	10K
3503	-	-	-	-
3508	39K	39K	-	-
3519	2R2	2R2	1R	1R
3520	2R2	2R2	1R	1R
3523	2R2	2R2	1R	1R
3524	2R2	2R2	1R	1R
4400	-	-	X	X
4406	X	X	X	X
4409	X	X	X	X
4411	X	X	X	X
4413	-	-	-	-
4420	X	X	X	X
4421	X	X	X	X
4422	-	-	-	-
4424	X	X	X	X
4427	X	X	X	X
4438	X	-	X	-
4457	X	-	X	-
4458	X	X	X	X
4459	-	-	-	-
5404	2U2	2U2	2U2	2U2
5405	2U2	2U2	2U2	2U2
5406	2U2	2U2	2U2	2U2
9400	-	-	-	-
9404	-	-	-	-
9405	X	X	X	X
9449	-	-	-	-
9450	-	-	-	-
9451	-	-	-	-

X - Item in use.

TOP KEY BOARD - COMPONENT LAYOUT

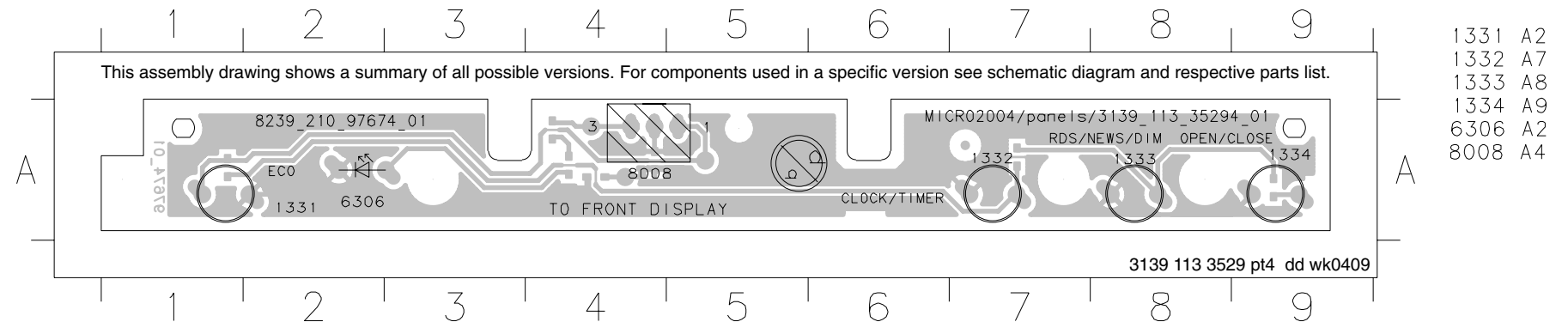

- 1331 A2
- 1332 A7
- 1333 A8
- 1334 A9
- 6306 A2
- 8008 A4

TOP KEY BOARD - CHIP LAYOUT

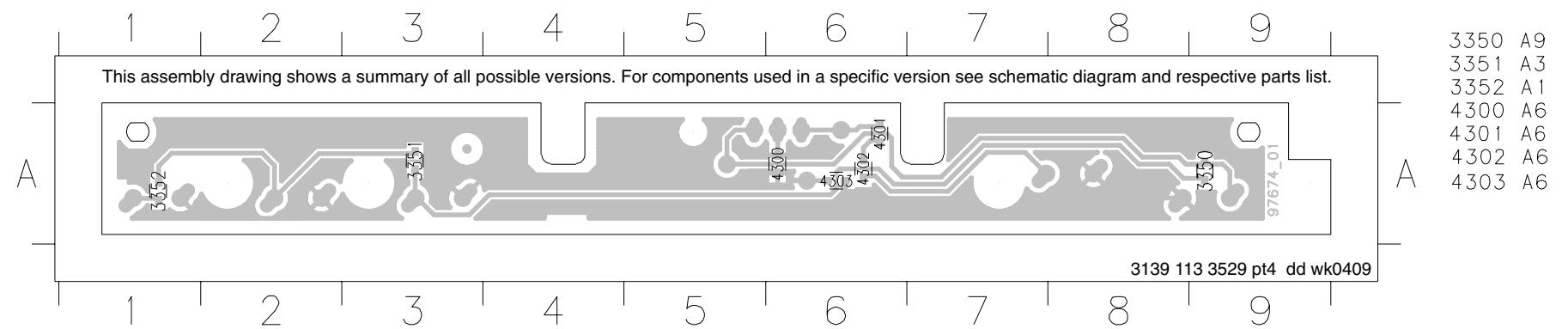

- 3350 A9
- 3351 A3
- 3352 A1
- 4300 A6
- 4301 A6
- 4302 A6
- 4303 A6

TOP KEY BOARD - CIRCUIT DIAGRAM

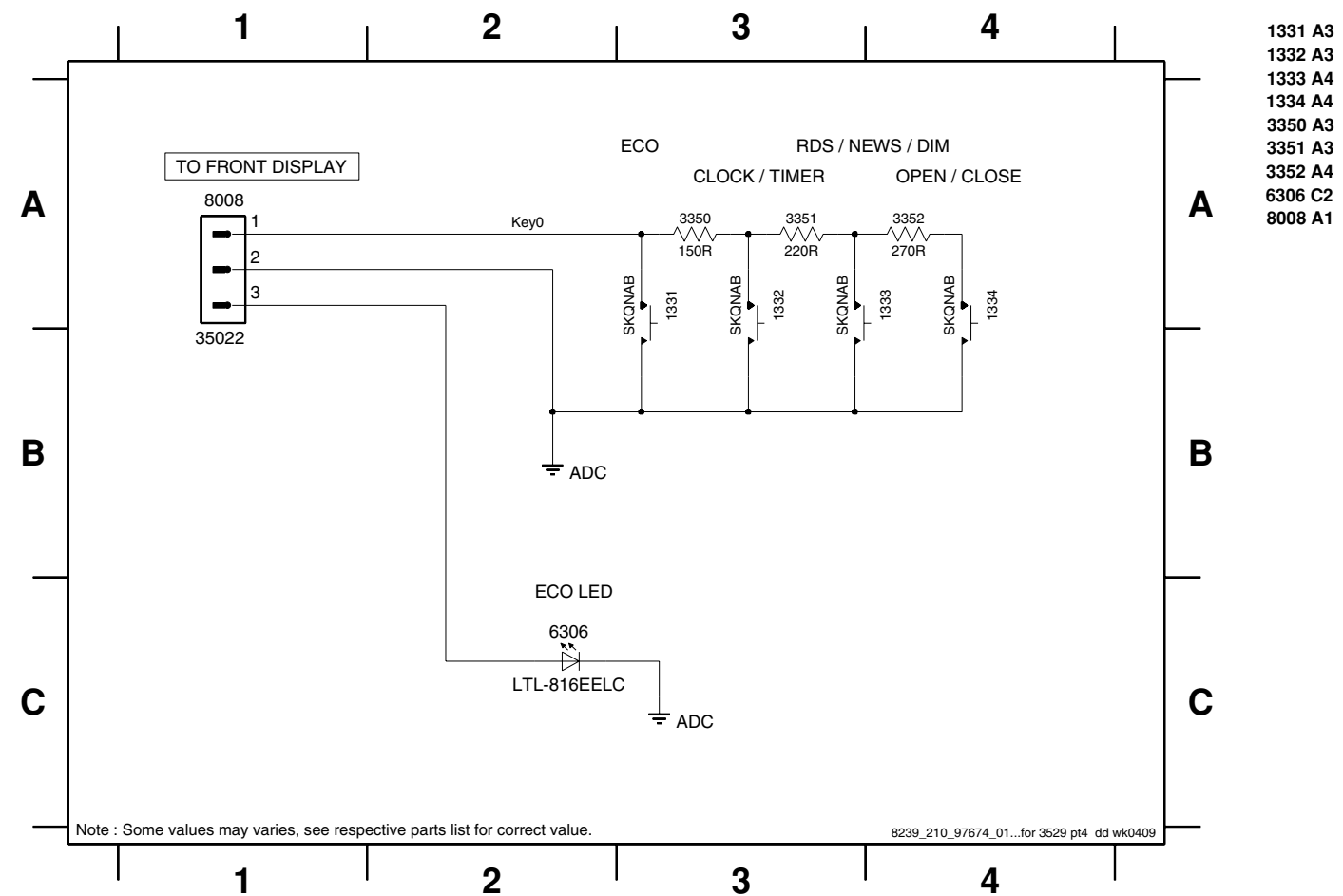

- 1331 A3
- 1332 A3
- 1333 A4
- 1334 A4
- 3350 A3
- 3351 A3
- 3352 A4
- 6306 C2
- 8008 A1

CONTROL BOARD - COMPONENT LAYOUT

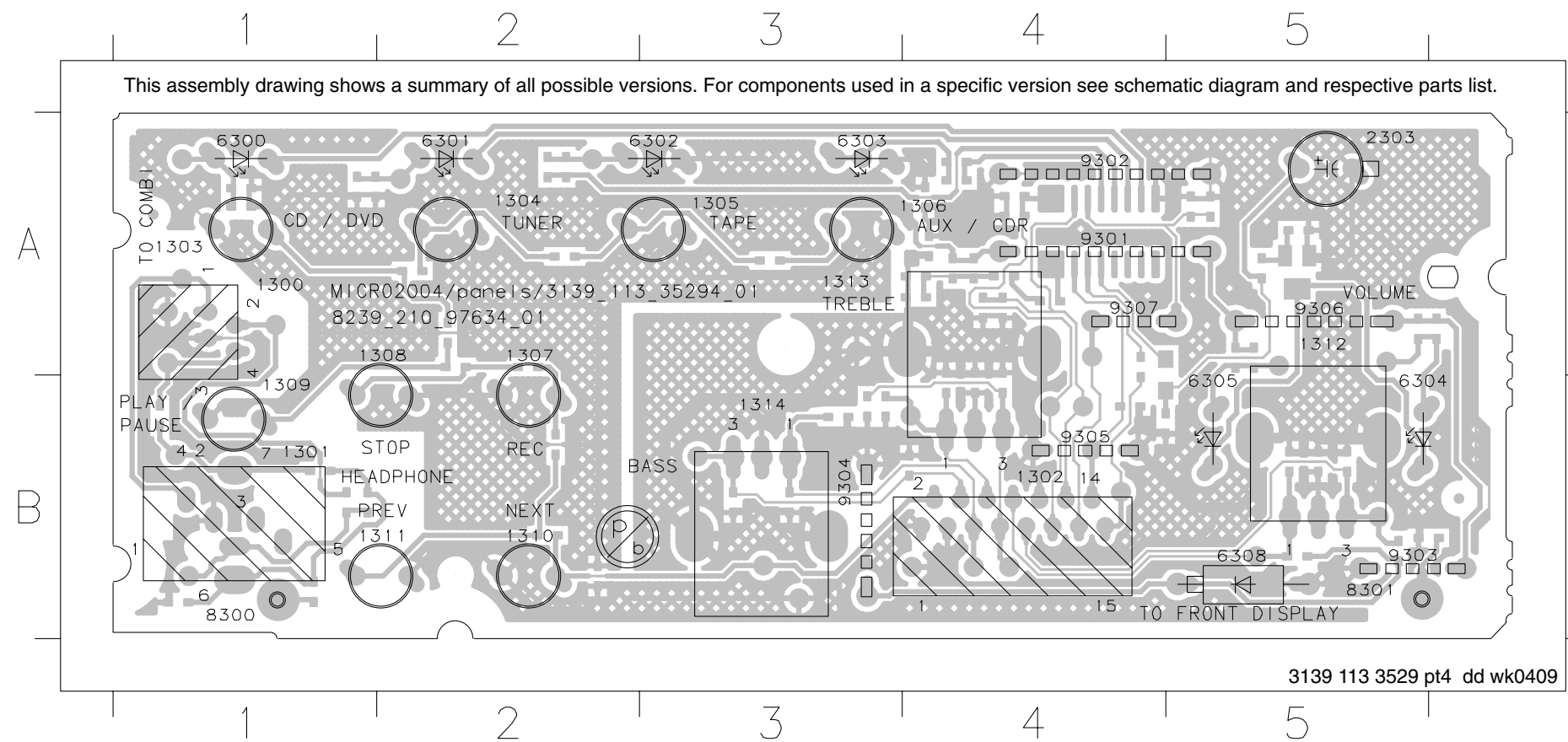

1300	A1	9305	B4
1301	B1	9306	A5
1302	B4	9307	A4
1303	A1		
1304	A2		
1305	A3		
1306	A4		
1307	A2		
1308	A2		
1309	B1		
1310	B2		
1311	B2		
1312	A5		
1313	A3		
1314	B3		
2303	A5		
6300	A1		
6301	A2		
6302	A3		
6303	A3		
6304	B5		
6305	B5		
6308	B5		
8300	B1		
8301	B5		
9301	A4		
9302	A4		
9303	B5		
9304	B3		

CONTROL BOARD - CHIP LAYOUT

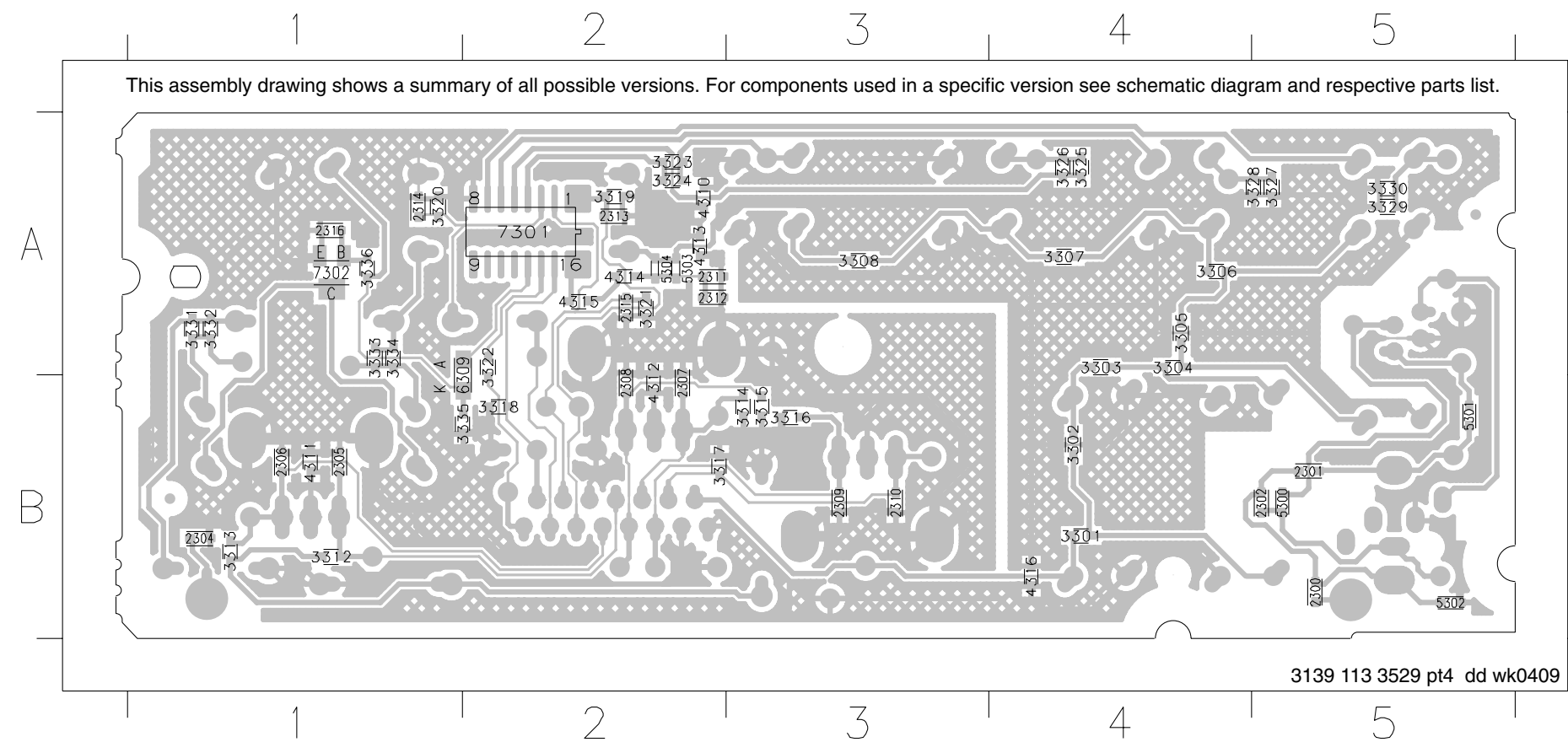

2300	B5	3317	B2	5302	B5
2301	B5	3318	B2	5303	A2
2302	B5	3319	A2	5304	A2
2304	B1	3320	A1	6309	A1
2305	B1	3321	A2	7301	A2
2306	B1	3322	A2	7302	A1
2307	B2	3323	A2		
2308	B2	3324	A2		
2309	B3	3325	A4		
2310	B3	3326	A4		
2311	A2	3327	A5		
2312	A2	3328	A5		
2313	A2	3329	A5		
2314	A1	3330	A5		
2315	A2	3331	A1		
2316	A1	3332	A1		
3301	B4	3333	A1		
3302	B4	3334	A1		
3303	A4	3335	B1		
3304	A4	3336	A1		
3305	A4	4310	A2		
3306	A4	4311	B1		
3307	A4	4312	B2		
3308	A3	4313	A2		
3312	B1	4314	A2		
3313	B1	4315	A2		
3314	B3	4316	B4		
3315	B3	5300	B5		
3316	B3	5301	B5		

CONTROL BOARD - CIRCUIT DIAGRAM PART 1

1300 A7 1302 A1 1304 A5 1306 A6 1308 A4 1310 A3 1312 E2 1314 E5 2301 A8 2304 E2 2306 E3 2308 E5 2310 E6 3302 A3 3304 A4 3306 A5 3308 A5 3313 D3 3315 D5 3317 D6 5301 A8 6308 D2 8301 E2
 1301 A9 1303 A5 1305 A5 1307 A3 1309 A4 1311 A3 1313 E4 2300 B8 2302 A9 2305 E3 2307 E4 2309 E6 3301 A3 3303 A4 3305 A4 3307 A5 3312 D3 3314 D4 3316 D6 5300 A8 5302 B8 8300 B7

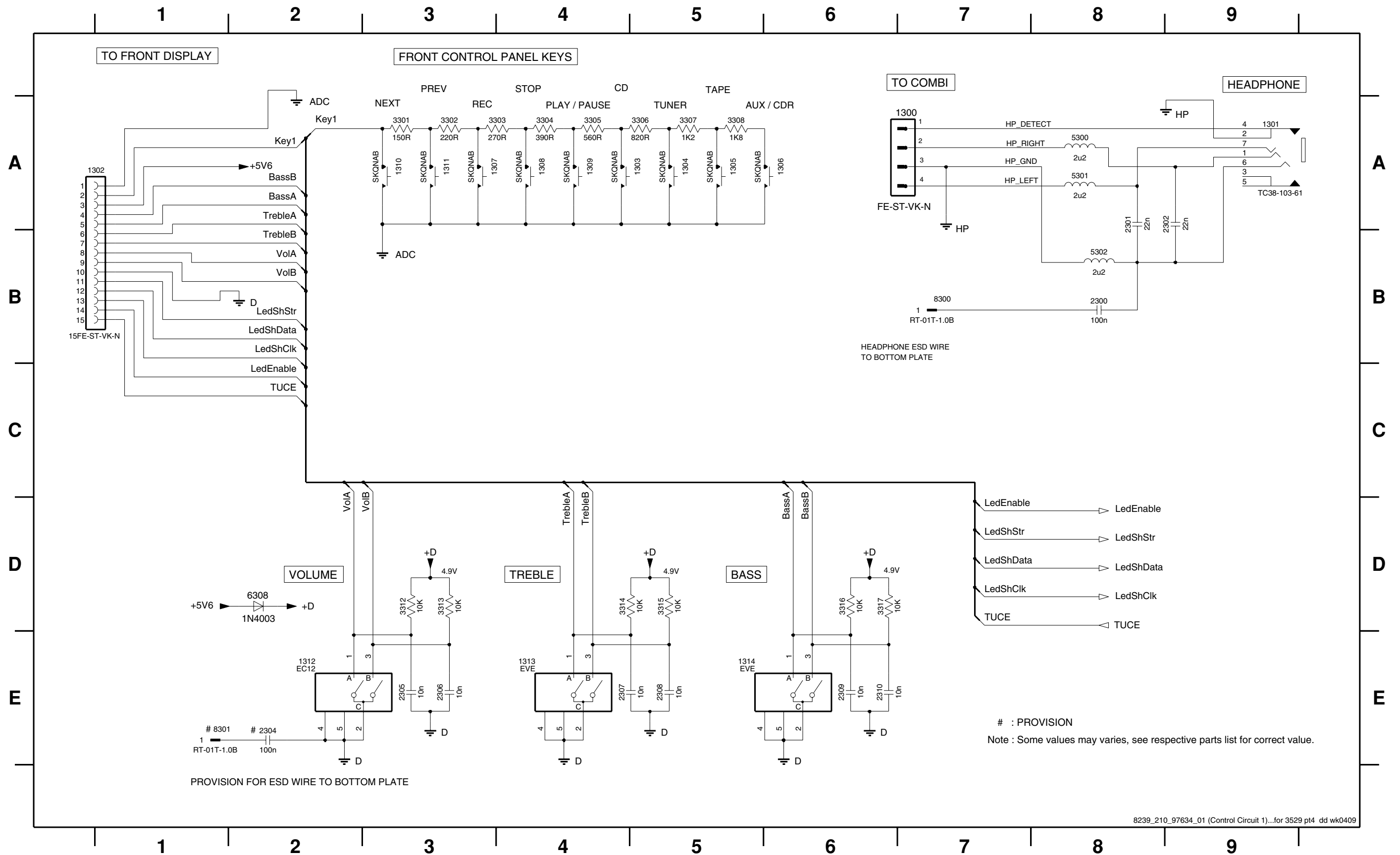

CONTROL BOARD - CIRCUIT DIAGRAM PART 2

2303 D5 2312 A4 2314 C3 2316 C8 3319 C2 3321 D2 3323 B5 3325 B6 3327 B7 3329 B7 3331 B8 3333 B9 3335 D5 5303 A3 6300 B8 6302 B6 6304 B8 6309 C5 7302 C9
 2311 A4 2313 C3 2315 D3 3318 B2 3320 C2 3322 E2 3324 B6 3326 B6 3328 B7 3330 B8 3332 B8 3334 B9 3336 C5 5304 A3 6301 B7 6303 B5 6305 B9 7301 B3

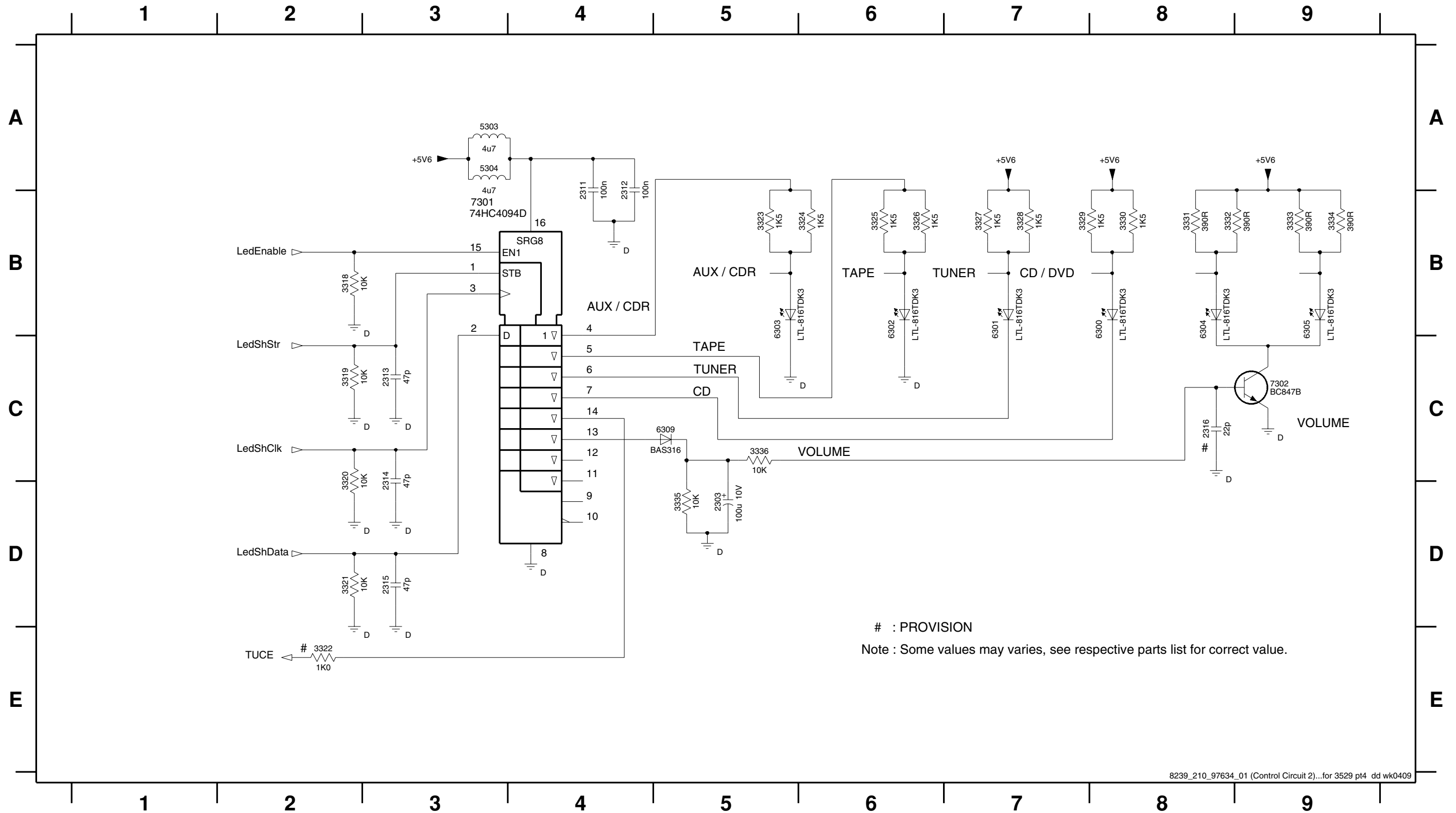

EEPROM BOARD - COMPONENT LAYOUT

1600 A1 3603 A2 3607 A2 9600 A1
 2604 B2 3606 A2 5602 A2

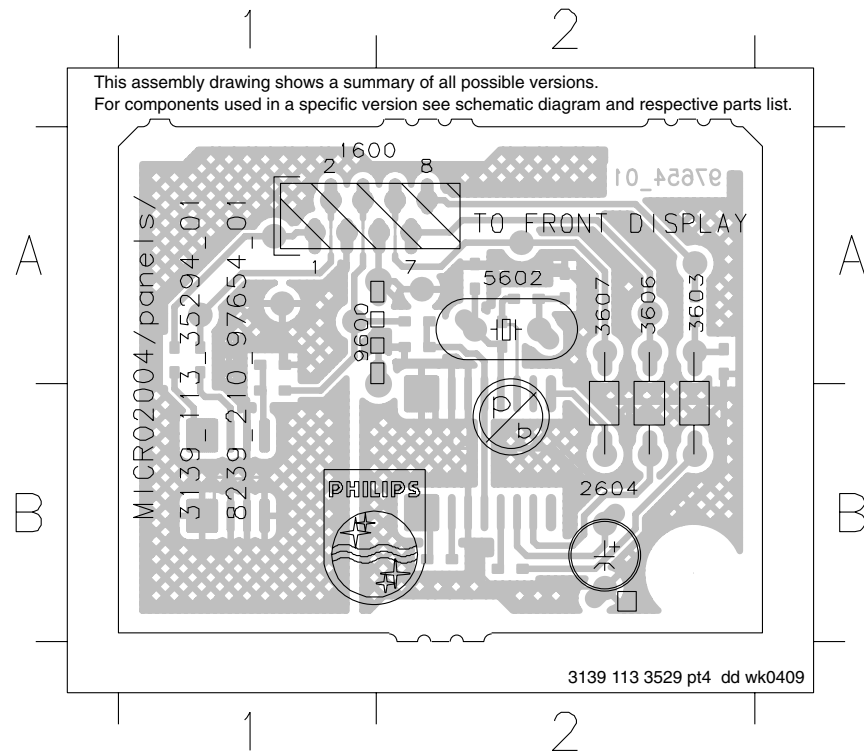

EEPROM BOARD - CHIP LAYOUT

2600 A2 2605 A1 3601 A2 5600 B2
 2601 A1 2606 A1 3602 A1 5601 A1
 2602 B1 2607 A1 3604 A1 7600 B2
 2603 B1 3600 A2 3605 A1 7601 B1

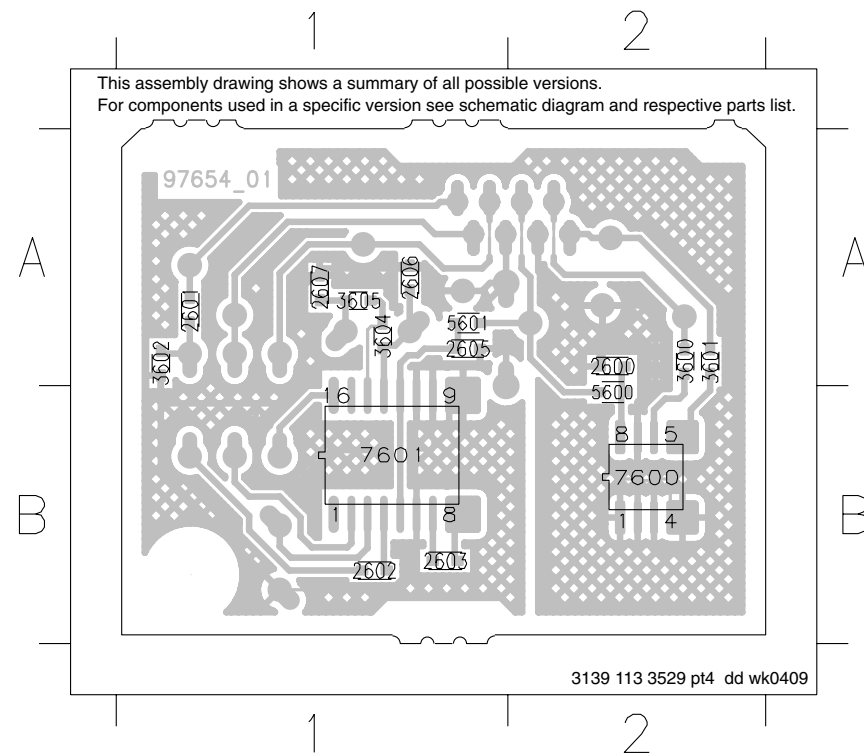

EEPROM BOARD - CIRCUIT DIAGRAM

1600 A4 2601 C1 2603 D1 2605 D4 2607 E3 3601 B2 3603 C1 3605 E2 3607 D3 5601 C2 7600 A1
 2600 A2 2602 D1 2604 D3 2606 E2 3600 B2 3602 C1 3604 E2 3606 D3 5600 A1 5602 E2 7601 C1

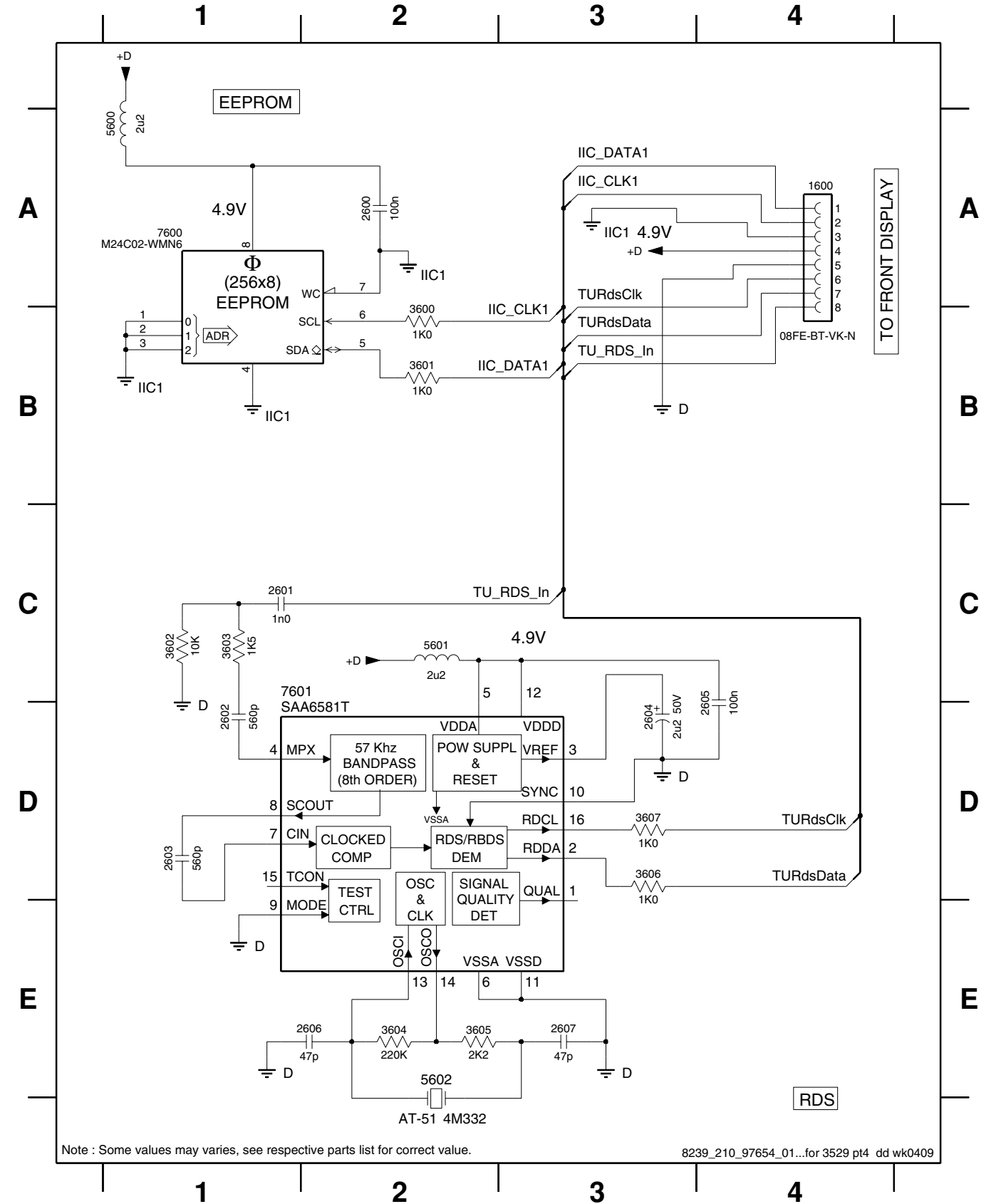

ELECTRICAL PARTS - FRONT BOARD

1301	2422 026 05563	SOC PHONE V 1P F 3.5 ST
1303	4822 276 13775	SWITCH
1304	4822 276 13775	SWITCH
1305	4822 276 13775	SWITCH
1306	4822 276 13775	SWITCH
1307	4822 276 13775	SWITCH
1308	4822 276 13775	SWITCH
1309	4822 276 13775	SWITCH
1310	4822 276 13775	SWITCH
1311	4822 276 13775	SWITCH
1312	9940 000 02116	ROTARY ENCODER
1313	9940 000 02117	ROTARY ENCODER
1314	9940 000 02117	ROTARY ENCODER
1331	4822 276 13775	SWITCH
1332	4822 276 13775	SWITCH
1333	4822 276 13775	SWITCH
1334	4822 276 13775	SWITCH
1400	3139 110 53601	FTD HNA-13SM42 (MCM7)
5400	5322 242 73686	CST12,00MTW-TF01
6300	9940 000 02114	LED 3MM SUPER BLUE
6301	9940 000 02114	LED 3MM SUPER BLUE
6302	9940 000 02114	LED 3MM SUPER BLUE
6303	9940 000 02114	LED 3MM SUPER BLUE
6304	9940 000 02114	LED 3MM SUPER BLUE
6305	9940 000 02114	LED 3MM SUPER BLUE
6306	9940 000 02115	LED 3MM 3R4HD-7(REDF)
7301	4822 209 15449	74HC4094D
7400	9940 000 02112	IC 88CU74YFG-6C67(TZ) MASK
7403	9322 185 95667	IR RECEIVER TSOP4836
7600	9940 000 02113	IC M24C02-WMN6 EEPROM
	9940 000 02123	FFC CABLE 9P L=180MM
	9940 000 02124	FFC CABLE 19P L=180MM
	9940 000 02125	FFC CABLE 15P L=130MM

Note: Only these parts mentioned in the list are normal service parts.

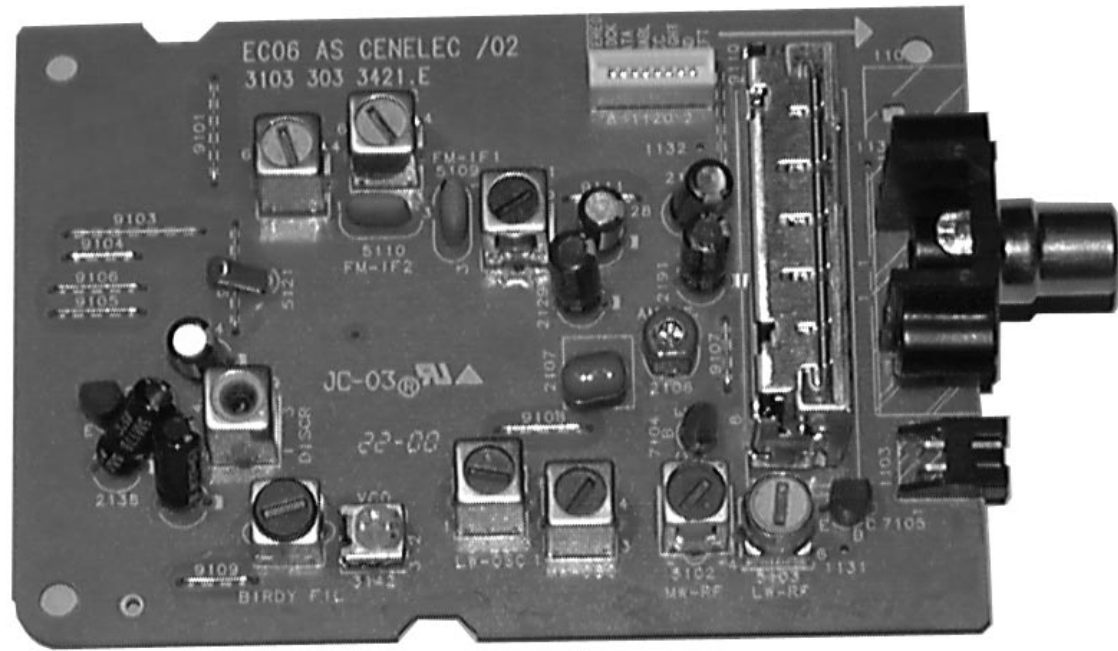

ECO6 Tuner Board

version: **SYSTEMS CENELEC**

TABLE OF CONTENTS

Blockdiagram.....	7B-1
Schematic Diagram.....	7B-2
Component Layout.....	7B-3
Adjustment table.....	7B-3
Electrical Partslist.....	7B-4

BLOCK DIAGRAM

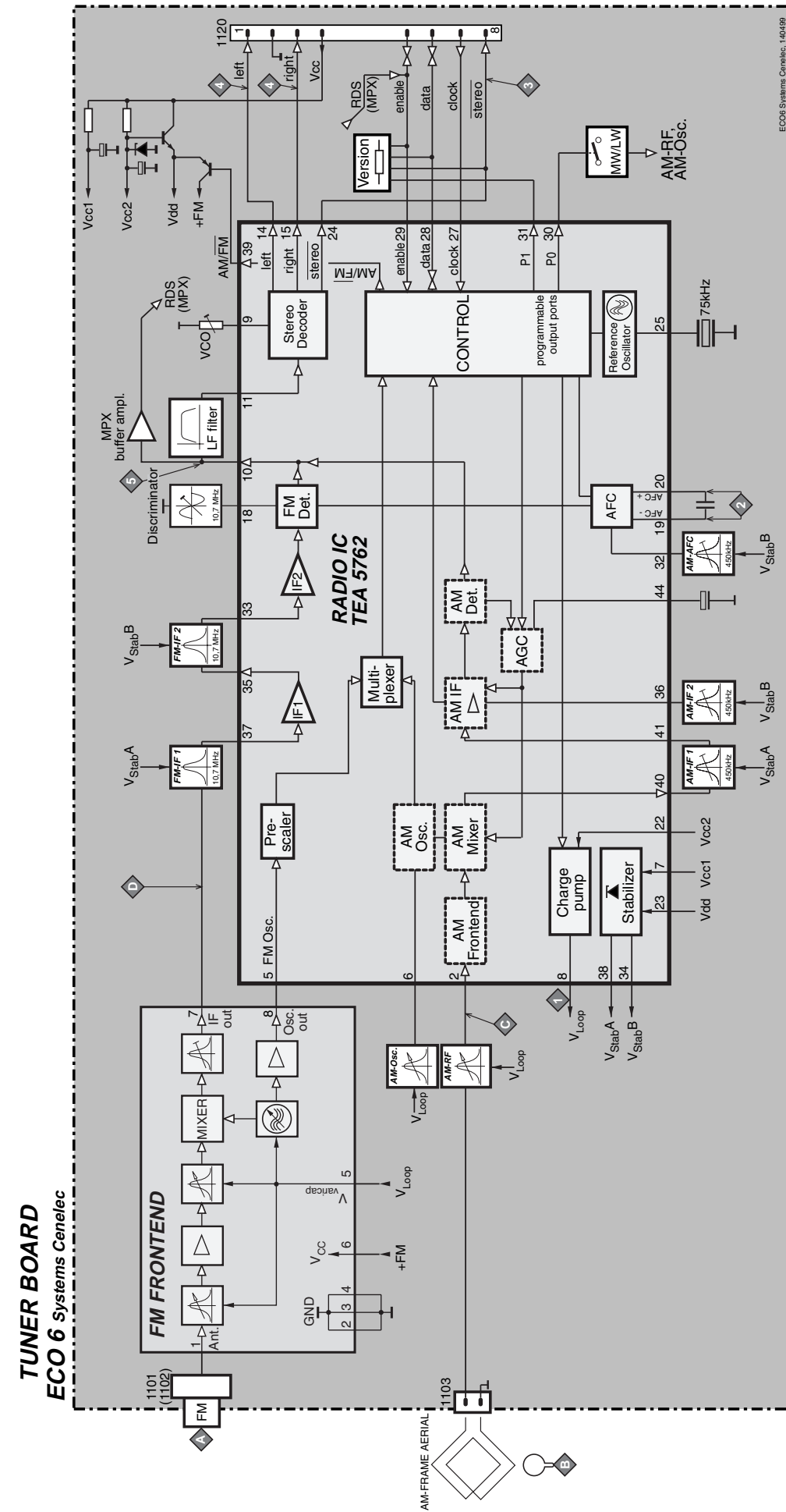

TUNER BOARD ECO6 / SYSTEMS-CENELEC

VERSION PROGRAMMING COMPONENTS

VERSION	6120	3156	3157	3170	7111
/00 /02 FM/MW/LW					
/00 /02 FM/MW					
/01 FM/MW					
/14 FM-OIRT/MW					
/17 FM/AM					

☒ component mounted

VERSION DETECTION

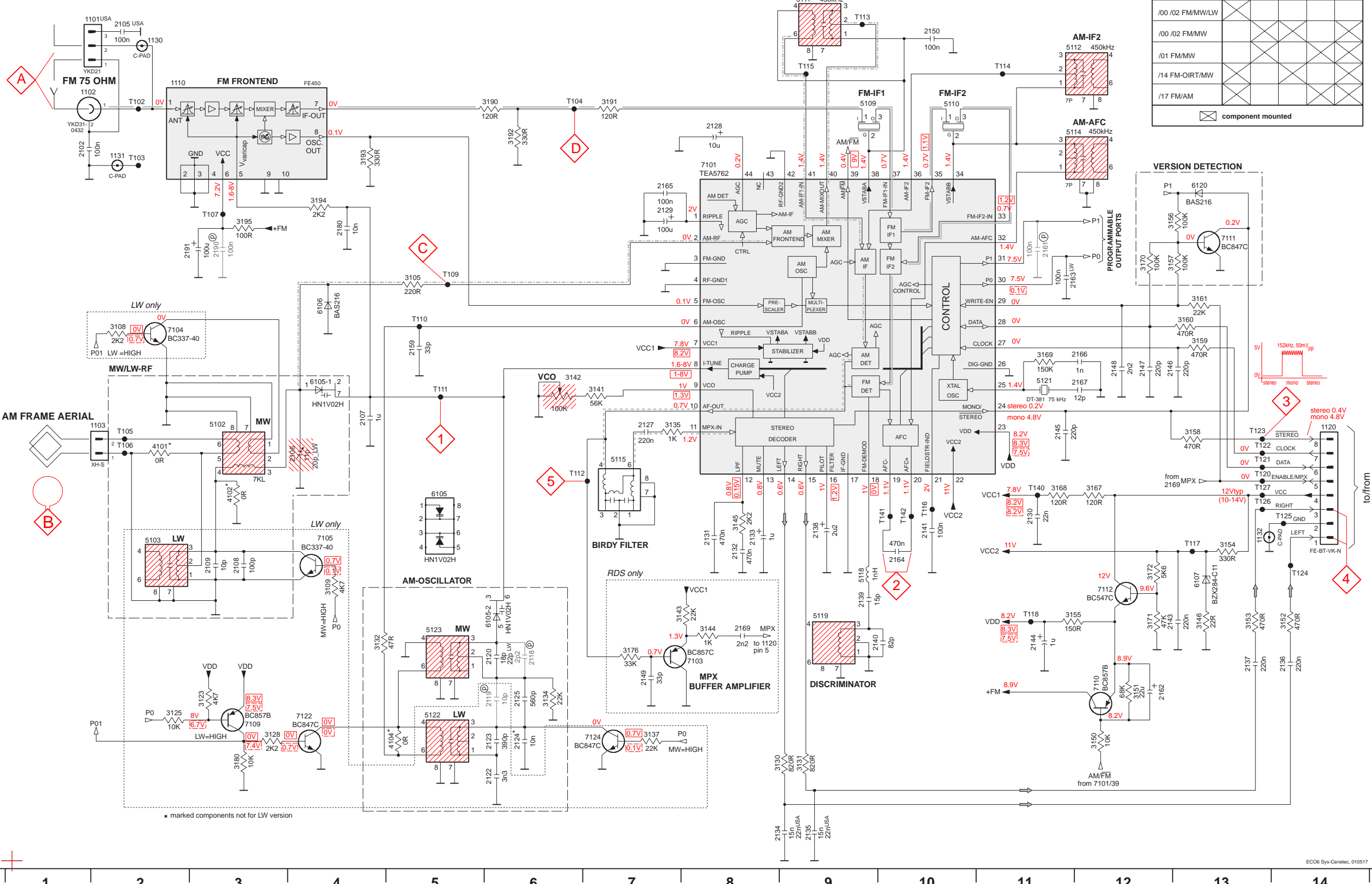
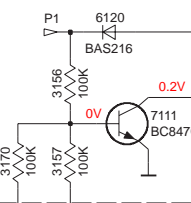

- 1101 A2
- 1102 B1
- 1103 E5
- 1110 B4
- 1120 E14
- 1130 A2
- 1131 C2
- 1132 F13
- 1132 B1
- 2105 A2
- 2106 E3
- 2107 E4
- 2108 G3
- 2109 G3
- 2118 H6
- 2119 H6
- 2120 H6
- 2122 I6
- 2123 H6
- 2124 H6
- 2125 H6
- 2127 E7
- 2128 B8
- 2129 C7
- 2130 F11
- 2131 F8
- 2132 F8
- 2133 F8
- 2134 I8
- 2135 I9
- 2136 H14
- 2137 H13
- 2138 F9
- 2139 G9
- 2140 G9
- 2141 F10
- 2143 G12
- 2144 G11
- 2145 E11
- 2146 E12
- 2147 E12
- 2148 E12
- 2149 H7
- 2150 A10
- 2159 D5
- 2161 C11
- 2162 H12
- 2163 D11
- 2164 G10
- 2165 C7
- 2166 E11
- 2167 E11
- 2169 G8
- 2180 C4
- 2190 C3
- 2191 C3
- 3105 D5
- 3108 D2
- 3109 G4
- 3123 H3
- 3125 H2
- 3128 H3
- 3130 I9
- 3131 I9
- 3132 G4
- 3134 H6
- 3135 E7
- 3137 H7
- 3141 E7
- 3142 E6
- 3143 G7
- 3144 G8
- 3145 F8
- 3146 G13
- 3150 H12
- 3151 H12
- 3152 G14
- 3153 G13
- 3154 F13
- 3155 G12
- 3156 C12
- 3157 D12
- 3158 E13
- 3159 D13
- 3160 D13
- 3161 D13
- 3167 F12
- 3168 F11
- 3169 E11
- 3170 D12
- 3171 G12
- 3172 G12
- 3176 H7
- 3180 I3
- 3190 B6
- 3191 B7
- 3192 B6
- 3193 B4
- 3194 C4
- 3195 C3
- 4101 E2
- 4102 F3
- 4104 H5
- 5102 E3
- 5103 F2
- 5109 B9
- 5110 B10
- 5111 A9
- 5112 A11
- 5114 B11
- 5115 E7
- 5118 G9
- 5119 G9
- 5121 E11
- 5122 H5
- 5123 G5
- 6105-1 E4
- 6105-2 G6
- 6106 D4
- 6107 G13
- 6120 C13
- 7101 C8
- 7103 H8
- 7104 D2
- 7105 F4
- 7109 H3
- 7110 H12
- 7111 C13
- 7112 G12
- 7122 H4
- 7124 H7
- T102 B2
- T103 B2
- T104 B6
- T105 B6
- T106 B6
- T107 B6
- T109 C2
- T110 C2
- T111 C2
- T112 C2
- T113 C2
- T114 C2
- T115 C2
- T120 C2
- T121 C2
- T122 C2
- T123 C2
- T124 C2
- T125 C2
- T126 C2
- T127 C2
- T128 C2
- T129 C2
- T130 C2
- T131 C2
- T132 C2
- T133 C2
- T134 C2
- T135 C2
- T136 C2
- T137 C2
- T138 C2
- T139 C2
- T140 C2
- T141 C2
- T142 C2
- T143 C2
- T144 C2
- T145 C2
- T146 C2
- T147 C2
- T148 C2
- T149 C2
- T150 C2

LEGEND

- *... only assembled in FM/AM-version
- Ⓢ... for provision only
- USA ... for USA version only
- LW ... for LW version only

- SMD jumper
- 41xx
- OR

- ...V FM mode stereo
- ...V MW mode
- ...V LW mode
- voltages measured while set is tuned to a strong transmitter

Signal path

- FM
- - - AM
- MPX (Audio Frequency)
- ⇒ AF - left/right

1101 B5 1110 B4 1131 C5 2107 B3 2133 C1 2162 A4 5102 C4 5110 A2 5114 A2 5121 B2 7104 C4 9101 A2 9104 B1 9107 B4 9110 A4
 1102 B5 1120 A4 1132 A4 2128 A3 2138 B1 2191 B4 5103 C4 5111 A3 5115 C2 5122 C3 7105 C5 9102 B2 9105 B1 9108 B3 9111 A3
 1103 C5 1130 A5 2106 B4 2129 B3 2144 B1 3142 C2 5109 B3 5112 A2 5119 B2 5123 C3 7112 B1 9103 A1 9106 B1 9109 C2

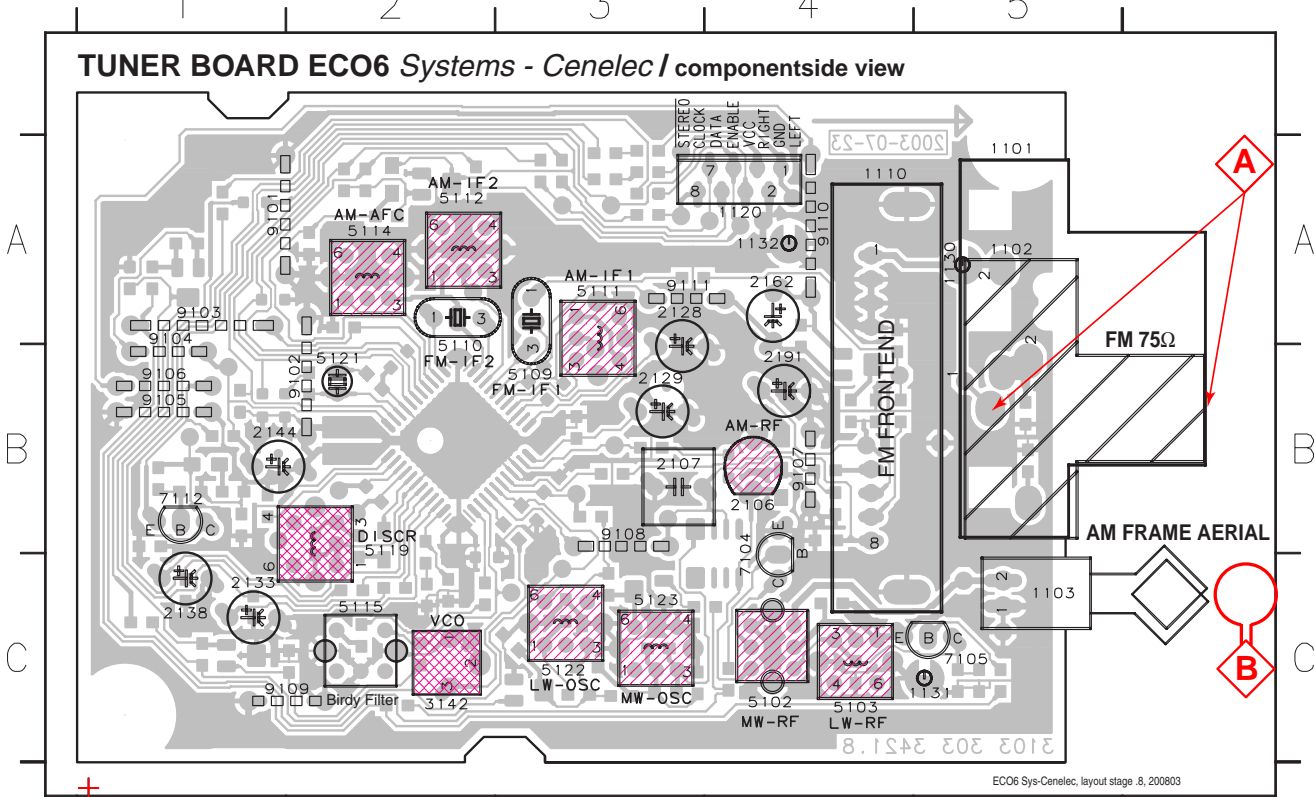

2102 B1 2120 C3 2130 B3 2137 A3 2146 B5 2161 A4 2169 A3 3123 A5 3134 C3 3145 C4 3154 B5 3160 A3 3171 B5 3192 A2 4104 C3 6106 B2 7110 B2
 2105 B1 2122 C3 2131 C4 2139 B4 2147 A5 2163 A4 2180 B2 3125 A5 3135 C4 3146 B5 3155 B5 3161 A4 3172 B5 3193 B2 4105 B2 6107 B5 7111 A4
 2108 C1 2123 C3 2132 C4 2140 B4 2148 B4 2164 B4 2190 B2 3128 C2 3137 C4 3150 B3 3156 A4 3167 A5 3176 C4 3194 B2 4106 B3 6120 A4 7122 C3
 2109 C1 2124 C3 2134 C5 2141 B5 2149 C4 2165 B3 3105 B3 3130 C4 3141 B3 3151 A2 3157 A4 3168 C5 3180 A5 3195 B2 4107 C4 7101 B4 7124 C3
 2118 C3 2125 C3 2135 C5 2143 B5 2150 B3 2166 B5 3108 C2 3131 C4 3143 C5 3152 A3 3158 A3 3169 B4 3190 B2 4101 C2 5118 C4 7103 C5
 2119 C3 2127 C4 2136 A3 2145 B5 2159 B3 2167 B4 3109 C1 3132 B3 3144 A5 3153 A3 3159 A3 3170 A4 3191 A3 4102 C2 6105 B2 7109 A5

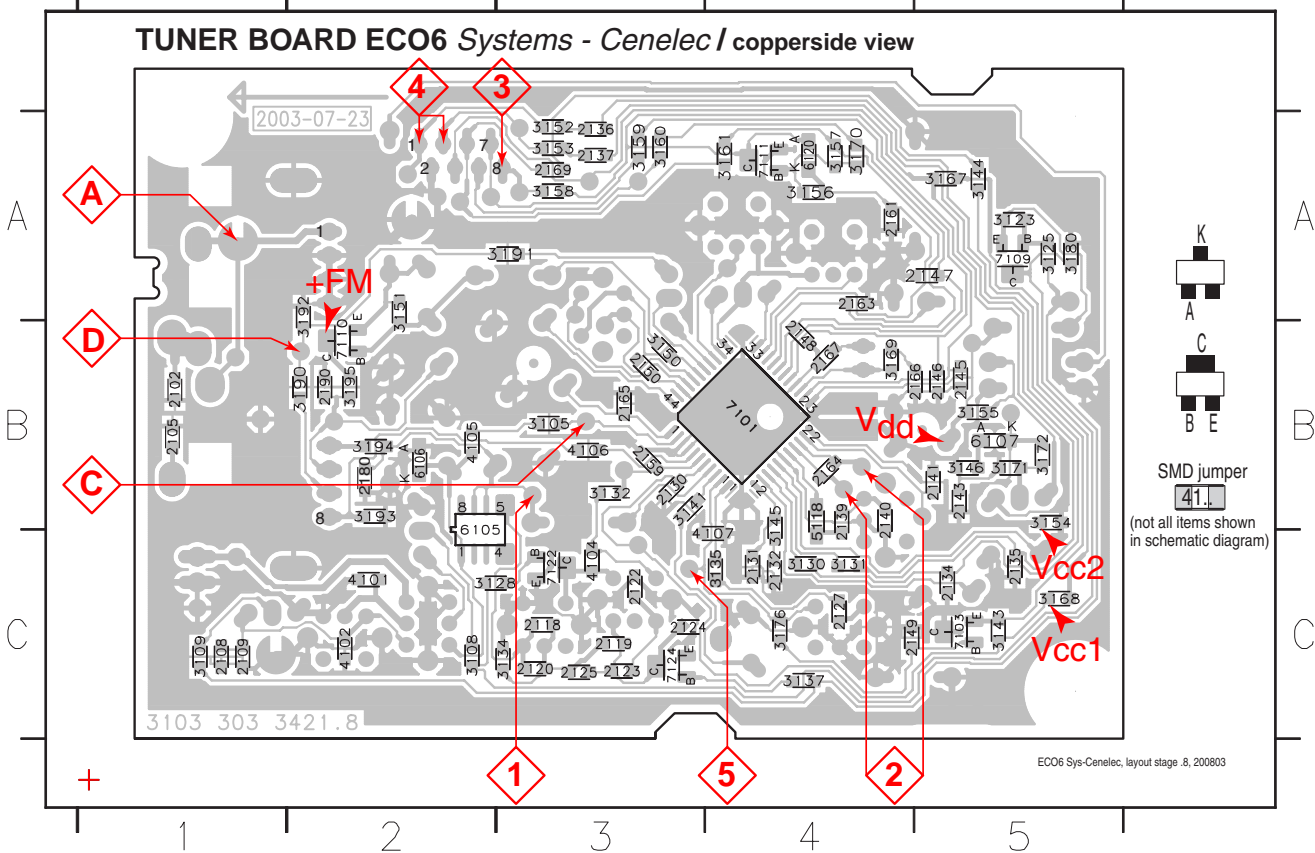

These assembly drawings show a summary of all possible versions.
 For components used in a specific version see schematic diagram respectively partslist.

TUNER ADJUSTMENT TABLE (ECO6 Cenelec FM/MW - and FM/MW/LW - versions with AM-frame aerial)

Waverange	Input frequency	Input	Tuned to	Adjust	Output	Scope/Voltmeter
VARICAP ALIGNMENT						
FM 87.5 - 108MHz (50kHz grid)			108MHz	check		8V ±1.2V
			87.5MHz	check		1.6V ±0.5V
MW 531 - 1602kHz (9kHz grid)			1602kHz	5123	1	8V ±0.2V 3-band 6.9V ±0.2V 2-band
			531kHz	check		1.1V ±0.4V
LW 153 - 279kHz (3kHz grid)			279kHz	5122		8V ±0.2V
			153kHz	check		1.1V ±0.4V
FM - IF						
FM	10.7MHz, 45mV continuous wave	D		5119	2	0mV ±3mV
FM - VCO						
FM	98MHz, 1mV continuous wave	A	98MHz	3142	3	152kHz ±1kHz ¹⁾
FM RF (channel separation) Note: The FM-frontend unit has already been adjusted by the factory and needs therefore no further adjustments for service purposes.						
FM	98MHz, 1mV 90% Left + 9% pilot mod=1kHz	A	98MHz	IF coil inside FM frontend 1110	4	right channel min.
AM IF						
MW	450kHz connect pin 6 of IC 7101 (AM Osc.) with 3.3kΩ to Vcc	C		5111	5	
				5112		
AM AFC MW	continuous wave V _{RF} = 2mV	C		5114	2	0mV ±2mV
AM RF³⁾						
MW	1494kHz	B	1494kHz	2106	5	
	558kHz					
LW	198kHz		198kHz	5103		

Use Service Testprogram. By selecting the TUNER TEST test frequencies will be stored as preset frequencies automatically.

- 1) If sensitivity of frequency counter is too low adjust to max. channel separation (input signal: stereo left 90% + 9%, adjust output on right channel to minimum)
- 2) RC network serves for damping the IF-filter while adjusting the other one.
- 3) For AM RF adjustments the original frame antenna has to be used!
 MW has to be aligned before LW.

↑ Repeat

MISCELLANEOUS

1101	2422 015 19376	SOCKET CLICKFIT 2P	USA only
1102	4822 267 10283	SOCKET COAX, IEC 75Ω	not USA
1103	4822 265 31184	JST CONNECTOR, 2 POLE	
1110	2422 542 90071	FM FRONTEND	
1120	4822 265 11515	FFC SOCKET, 8P	

CAPACITORS

2102	4822 126 13838	100nF	10%	50V	not USA
2105	4822 126 13838	100nF	10%	50V	USA only
2106	2020 800 00204	TRIMCAP. 4,2 - 20pF, N750			LW only
2106	2020 800 00191	TRIMCAP. 3 - 11pF, N450			FM/AM only
2107	4822 121 51319	1μF	20%	50V	
2108	5322 122 32531	100pF	5%	50V	LW only
2109	5322 122 32448	10pF	5%	50V	LW only
2120	4822 126 13689	18pF	1%	63V	FM/AM only
2120	5322 122 32658	22pF	5%	50V	LW only
2122	4822 122 33891	3,3nF	10%	63V	LW only
2123	2020 552 93494	390pF	1%	50V	LW only
2124	4822 122 33177	10nF	20%	50V	FM/AM only
2125	2020 552 96199	560pF	1%	50V	
2127	4822 126 14076	220nF	20%	25V	
2128	4822 124 40248	10μF	20%	63V	
2129	4822 124 41584	100μF	20%	10V	
2130	5322 122 32654	22nF	10%	63V	
2131	4822 126 13482	470nF	20%	16V	
2132	4822 126 13482	470nF	20%	16V	
2133	4822 124 21913	1μF	20%	63V	
2134	3198 017 31530	15nF	10%	50V	not USA
2134	5322 122 32654	22nF	10%	63V	USA only
2135	3198 017 31530	15nF	10%	50V	not USA
2135	3198 017 32230	22nF	10%	25V	USA only
2136	4822 126 14076	220nF	20%	25V	
2137	4822 126 14076	220nF	20%	25V	
2138	4822 124 22652	2,2μF	20%	50V	
2139	4822 126 14236	15pF	5%	50V	
2140	4822 126 13695	82pF	1%	63V	
2141	4822 126 13838	100nF	10%	50V	
2143	4822 126 14076	220nF	20%	25V	
2144	4822 124 21913	1μF	20%	63V	
2145	4822 122 33575	220pF	5%	50V	
2146	4822 122 33575	220pF	5%	50V	
2147	4822 122 33575	220pF	5%	50V	
2148	4822 122 33127	2,2nF	10%	63V	
2149	5322 122 32659	33pF	5%	50V	RDS only
2150	4822 126 13838	100nF	10%	50V	
2159	5322 122 31151	22μF	20%	50V	
2163	4822 126 13838	100nF	10%	50V	LW only
2164	4822 126 13482	470nF	20%	16V	
2165	4822 126 13838	100nF	10%	50V	
2166	5322 122 31647	1nF	10%	63V	
2167	4822 122 33926	12pF	5%	50V	
2169	4822 122 33127	2,2nF	10%	63V	RDS only
2180	3198 017 31030	10nF	10%	50V	
2190	4822 126 13838	100nF	10%	50V	
2191	4822 124 40178	100μF	20%	10V	

RESISTORS

3105	4822 117 11503	220Ω	5%	0,1W	
3108	4822 117 11449	2,2kΩ	1%	0,1W	LW only
3109	4822 051 20472	4,7kΩ	5%	0,1W	LW only
3123	4822 051 20472	4,7kΩ	5%	0,1W	LW only
3125	4822 117 10833	10kΩ	1%	0,1W	LW only

RESISTORS

3128	4822 117 11449	2,2kΩ	1%	0,1W	LW only
3130	3198 021 38210	820Ω	5%	0,06W	
3131	3198 021 38210	820Ω	5%	0,06W	
3132	4822 051 20479	47Ω	5%	0,1W	
3134	4822 051 20223	22kΩ	5%	0,1W	
3135	3198 021 31020	1kΩ	5%	0,06W	
3137	4822 051 20223	22kΩ	5%	0,1W	LW only
3141	4822 117 11148	56kΩ	1%	0,1W	
3142	4822 100 12159	TRIMPOT. 100kΩ			
3143	4822 051 20223	22kΩ	5%	0,1W	RDS only
3144	4822 051 10102	1kΩ	2%	0,25W	RDS only
3145	4822 117 11449	2,2kΩ	1%	0,1W	
3146	4822 051 20229	22Ω	5%	0,1W	
3150	4822 117 10833	10kΩ	1%	0,1W	
3151	4822 051 20683	68kΩ	5%	0,1W	
3152	4822 051 20471	470Ω	5%	0,1W	
3153	4822 051 20471	470Ω	5%	0,1W	
3154	4822 117 13577	330Ω	1%	0,1W	
3155	4822 117 10353	150Ω	5%	0,1W	
3156	4822 117 10837	100kΩ	1%	0,1W	
3157	4822 117 10837	100kΩ	1%	0,1W	
3158	4822 051 20471	470Ω	5%	0,1W	
3159	4822 051 20471	470Ω	5%	0,1W	
3160	4822 051 20471	470Ω	5%	0,1W	
3161	4822 051 20223	22kΩ	5%	0,1W	
3167	4822 051 20121	120Ω	5%	0,1W	
3168	4822 051 20121	120Ω	5%	0,1W	
3169	4822 051 20154	150kΩ	5%	0,1W	
3170	4822 117 10837	100kΩ	1%	0,1W	
3171	4822 117 10834	47kΩ	1%	0,1W	
3172	4822 051 20562	5,6kΩ	5%	0,1W	
3176	4822 051 20333	33kΩ	5%	0,1W	RDS only
3180	4822 117 10833	10kΩ	1%	0,1W	LW only
3190	4822 051 20121	120Ω	5%	0,1W	
3191	4822 051 20121	120Ω	5%	0,1W	
3192	4822 117 13577	330Ω	1%	0,1W	
3193	4822 117 13577	330Ω	1%	0,1W	
3194	4822 117 11449	2,2kΩ	1%	0,1W	
3195	4822 051 20101	100Ω	5%	0,1W	
4101	4822 051 20008	CHIP JUMPER 0805			FM/AM only
4102	4822 051 20008	CHIP JUMPER 0805			FM/AM only
4104	4822 051 20008	CHIP JUMPER 0805			FM/AM only
4105	4822 051 20008	CHIP JUMPER 0805			
4106	4822 051 20008	CHIP JUMPER 0805			
4107	4822 051 20008	CHIP JUMPER 0805			

COILS

5102	4822 157 71634	RF-COIL MW			
5103	2422 549 44107	RF-COIL LW			LW only
5109	4822 157 71639	FM-IF FILTER 10,7MHz			
5110	4822 242 70665	FM-IF FILTER 10,7MHz			
5111	2422 549 44023	AM-IF FILTER 450kHz			
5112	4822 157 70302	AM-IF FILTER 450kHz			
5114	4822 157 70302	AM-IF FILTER 450kHz			
5115	4822 157 71636	ANTI BIRDY FILTER			
5118	2422 535 95881	100nH			
5119	4822 157 11443	DISCRIMINATOR COIL			
5121	4822 242 10261	QUARTZ 75kHz			
5122	2422 549 44108	RF-COIL, LW-OSCILLATOR			LW only
5123	2422 549 44108	RF-COIL, MW-OSCILLATOR			

DIODES

6105	4822 130 83075	HN1V02H	
6106	4822 130 83757	BAS216	
6107	9340 386 90115	BZX284-C11	
6120	4822 130 83757	BAS216	

TRANSISTORS

7103	5322 130 42756	BC857C	RDS only
7104	9322 003 64676	TBC337-40	LW only
7105	9322 003 64676	TBC337-40	LW only
7109	4822 130 60373	BC856B	LW only
7110	4822 130 60373	BC856B	
7111	5322 130 42755	BC847C	
7112	4822 130 44503	BC547C	
7122	5322 130 42755	BC847C	LW only
7124	5322 130 42755	BC847C	LW only

INTEGRATED CIRCUITS

7101	4822 209 90315	TEA5762H/V1, RADIO IC	
------	----------------	-----------------------	--

MAINS BOARD

TABLE OF CONTENTS

Brief introduction	8-1
Mains Socket - Circuit diagram & Component layout	8-1
Mains Board - Component layout	8-2
Mains Board - Chip layout	8-3
Mains Board - Circuit diagram	8-4
Electrical parts list	8-5

Brief introduction of the Mains Board

ECO Power

Standby Transformer 5203 provides the LPS supply to control the relay 1210, cutting of the Mains supply to the Mains transformer during the ECO Power (standby) mode.

The Mains transformer provides the following:

- 5V6_ECO for Low Power Supply
- +A, +A/2 and +B to the Combi board

MAINS SOCKET - CIRCUIT DIAGRAM & COMPONENT LAYOUT

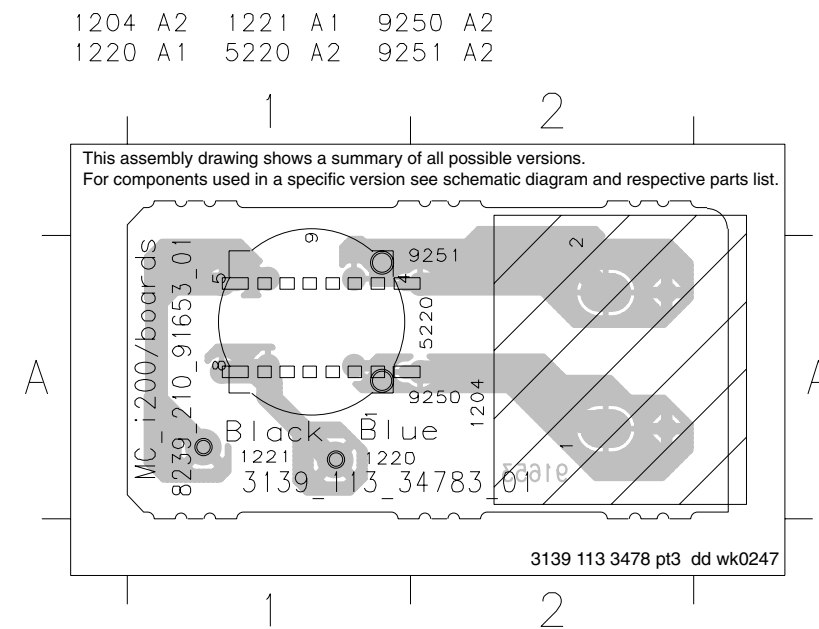

1204 A1 1220 A2 1221 A2 5220 A1 9250 A1 9251 A1

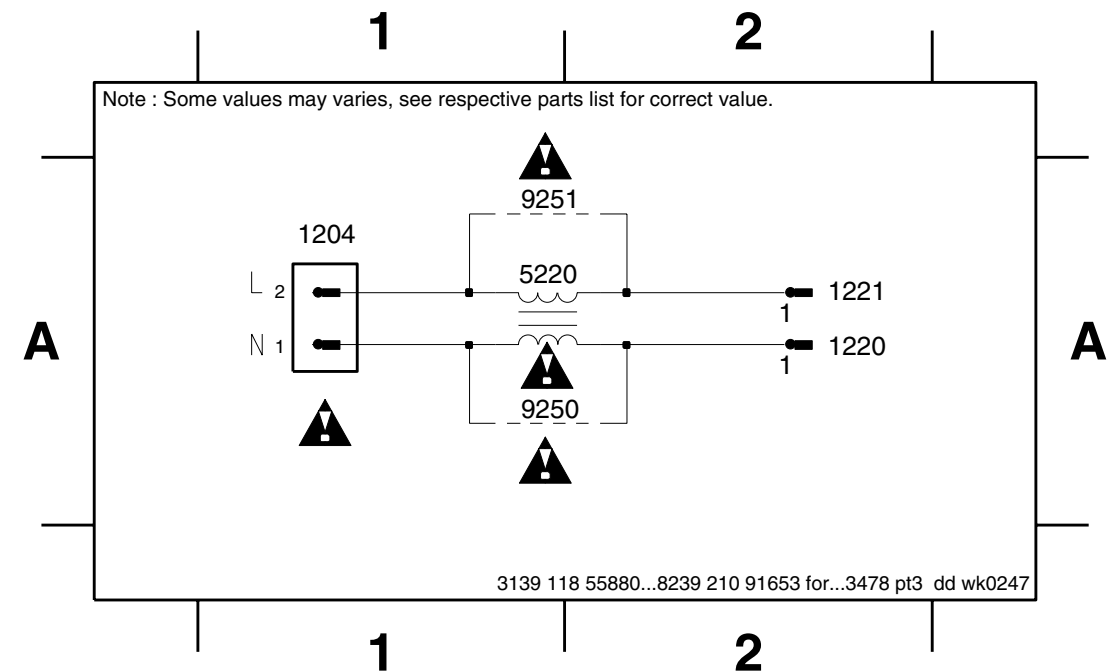

MAINS BOARD - COMPONENT LAYOUT

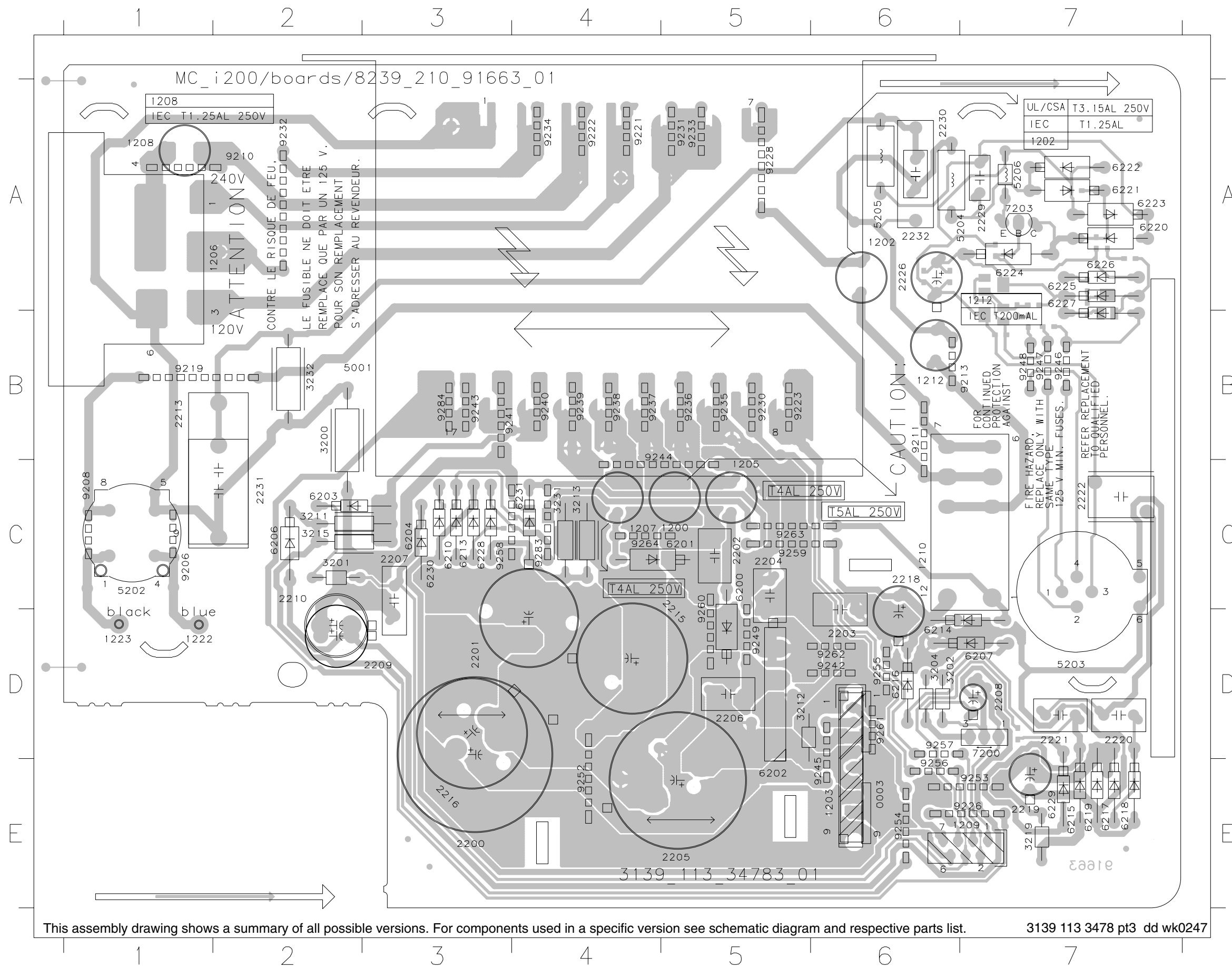

This assembly drawing shows a summary of all possible versions. For components used in a specific version see schematic diagram and respective parts list. 3139 113 3478 pt3 dd wk0247

MAINS BOARD - CIRCUIT DIAGRAM

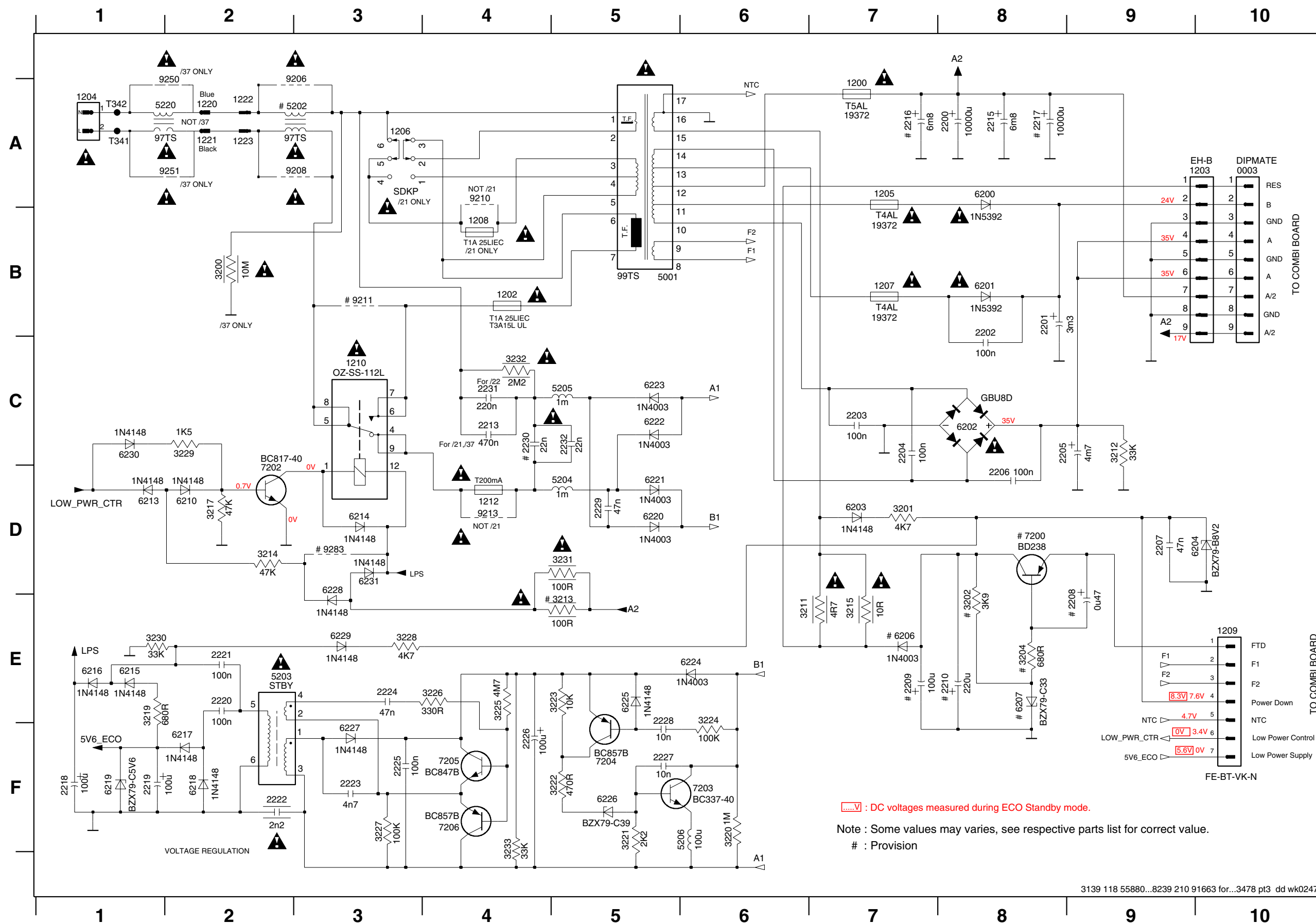

0003 A10	6219 F1
1200 A7	6220 D5
1202 B4	6221 D5
1203 A9	6222 C5
1205 A7	6223 C5
1206 A3	6224 E6
1207 B7	6225 E5
1208 B4	6226 F5
1209 E10	6227 F3
1210 C3	6228 D3
1212 D4	6229 E3
1222 A2	6230 C1
1223 A2	6231 D3
2200 A8	7200 D8
2201 B8	7202 D2
2202 B8	7203 F6
2203 C7	7204 E5
2204 C7	7205 F4
2205 C8	7206 F4
2206 D8	9206 A3
2207 D9	9208 A3
2208 E9	9210 A4
2209 E7	9211 B3
2210 E8	9213 D4
2213 C4	9283 D3
2215 A8	
2216 A7	
2217 A8	
2218 F1	
2219 F1	
2220 E2	
2221 E2	
2222 F2	
2223 F3	
2224 E3	
2225 F3	
2226 F4	
2227 F5	
2228 E5	
2229 D5	
2230 C4	
2231 C4	
2232 C5	
3200 B2	
3201 D7	
3202 E8	
3204 E8	
3211 E6	
3212 C9	
3213 E5	
3214 D2	
3215 E7	
3217 D2	
3219 E1	
3220 F6	
3221 F5	
3222 F5	
3223 E5	
3224 F6	
3225 E4	
3226 E4	
3227 F3	
3228 E3	
3229 C2	
3230 E1	
3231 D5	
3232 C4	
3233 F4	
5001 B5	
5202 A3	
5203 E3	
5204 D5	
5205 C5	
5206 F6	
6200 A8	
6201 B8	
6202 C8	
6203 D7	
6204 D9	
6206 E7	
6207 E8	
6210 D2	
6213 D1	
6214 D3	
6215 E1	
6216 E1	
6217 F2	
6218 F2	

[...V] : DC voltages measured during ECO Standby mode.
 Note : Some values may varies, see respective parts list for correct value.
 # : Provision

ELECTRICAL PARTS - MAINS BOARD

1104	2822 031 01494	FAN 12VDC 0.8W 3100RPM
1200	△ 2422 086 10963	FUSE RAD LT 5A 250V IEC A
1202	△ 4822 071 51252	FUSE 1.25A
1204	△ 4822 265 31015	AC POWER SOCKET
1205	△ 2422 086 10786	FUSE RAD 372 LT4A 250V
1207	△ 2422 086 10786	FUSE RAD 372 LT4A 250V
1210	△ 9940 000 02118	POWER RELAY 2P 12VDC 16A
3211	△ 4822 052 10478	4R70 5% 0,33W
3215	△ 4822 052 10109	10R00 5% 0,33W
3231	△ 4822 052 10101	100R00 5% 0,33W
5001	△ 3103 308 30780	TRAFO MAINS P2001 2X45W
5203	△ 2422 549 45157	TRAFO STANDBY 3A1631N
5220	△ 4822 157 11832	FILTER 400UH 3A
6202	△ 4822 130 11139	BRIDGE DIODE GBU8D
	9940 000 02126	FFC CABLE 7P L=220MM

Note: Only these parts mentioned in the list are normal service parts.

ETF8 TAPE MODULE

TABLE OF CONTENTS

Connector assignment 9-1
 Tape Module Wiring 9-2
 Tape Mechanism electronics 9-2
 Tape adjustment / Check Table 9-3
 HEF4094BT Functional Block & Application Logic Table ... 9-3
 ETF8 Board layouts - Components & Chips 9-4
 ETF8 Circuit diagram 9-5
 Exploded Views & mechanical parts list 9-6
 Electrical parts list 9-8

CONNECTORS ASSIGNMENTS:

CONNECTOR 1701

- 1 REC-L
- 2 REC-R
- 3 GND A
- 4 TAPE-L
- 5 +12V
- 6 TAPE-R
- 7 -CMOS

INTERCONNECTION TO AF BOARD

- Record input left
- Record input right
- AF Ground
- Playback output left
- D.C. supply (+12V) for AF electronics
- Playback output right
- Negative d.c. supply (-9V) for controlling JFET J111

CONNECTOR 1703

- 1 GND M
- 2 +MOTOR

INTERCONNECTION TO AF BOARD

- Motor Ground
- D.C. supply (+12V) for tape deck motor & solenoid

CONNECTOR 1706

- 1 CR_IN
- 2 AD1
- 3 +5V
- 4 GND_P
- 5 CLK
- 6 DATA
- 7 STROBE

INTERCONNECTION TO FRONT BOARD

- Deck sensing Chrome Tape
- Deck sensing switches output voltage / Deck EOT
- DC supply (+5V) for deck status ADC network (ref to microprocessor's supply)
- Control & Oscillator Ground
- HEF4094BT shift register Clock line
- HEF4094BT shift register Data line
- HEF4094BT shift register Strobe line

CONNECTOR 1710

- 1 GND A
- 2 ERASE HEAD
- 3 R/P HD Rch
- 4 Common
- 5 R/P HD Lch

TAPE HEAD CONNECTIONS

- Erase Head ground
- Erase Head
- R/P Head right channel positive
- Pb Head return ground shield
- R/P Head left channel positive

CONNECTOR 1760

- 1 Vcc 12V
- 2 PHOTO
- 3 GND_M
- 4 MODE
- 5 Sol_supply
- 6 CR_IN
- 7 REC FWD
- 8 REC REW

DECK CONTROL INTERFACE

- Deck / Motor supply
- Photo sensor output (tape movement indication)
- Deck / Motor ground
- Mode switch (head engagement)
- Solenoid supply
- Chrome tape detection switch
- Record tab protection status switch (forward)
- Record tab protection status switch (reverse)

TAPE DECK WIRING

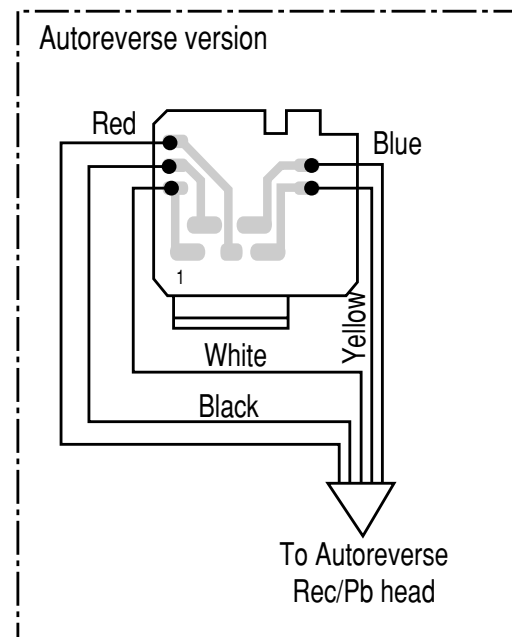
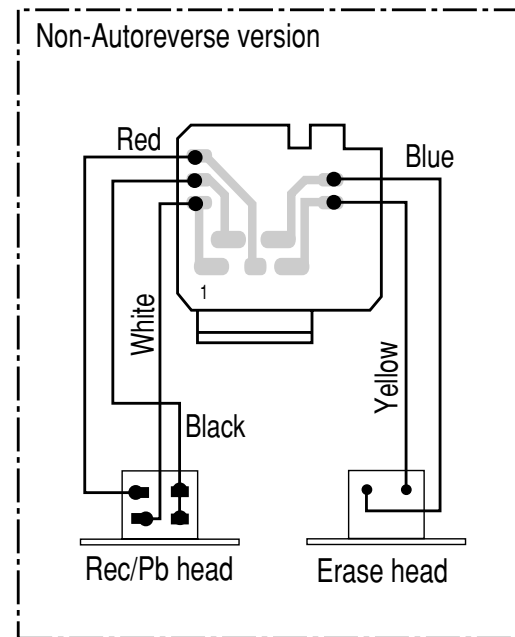
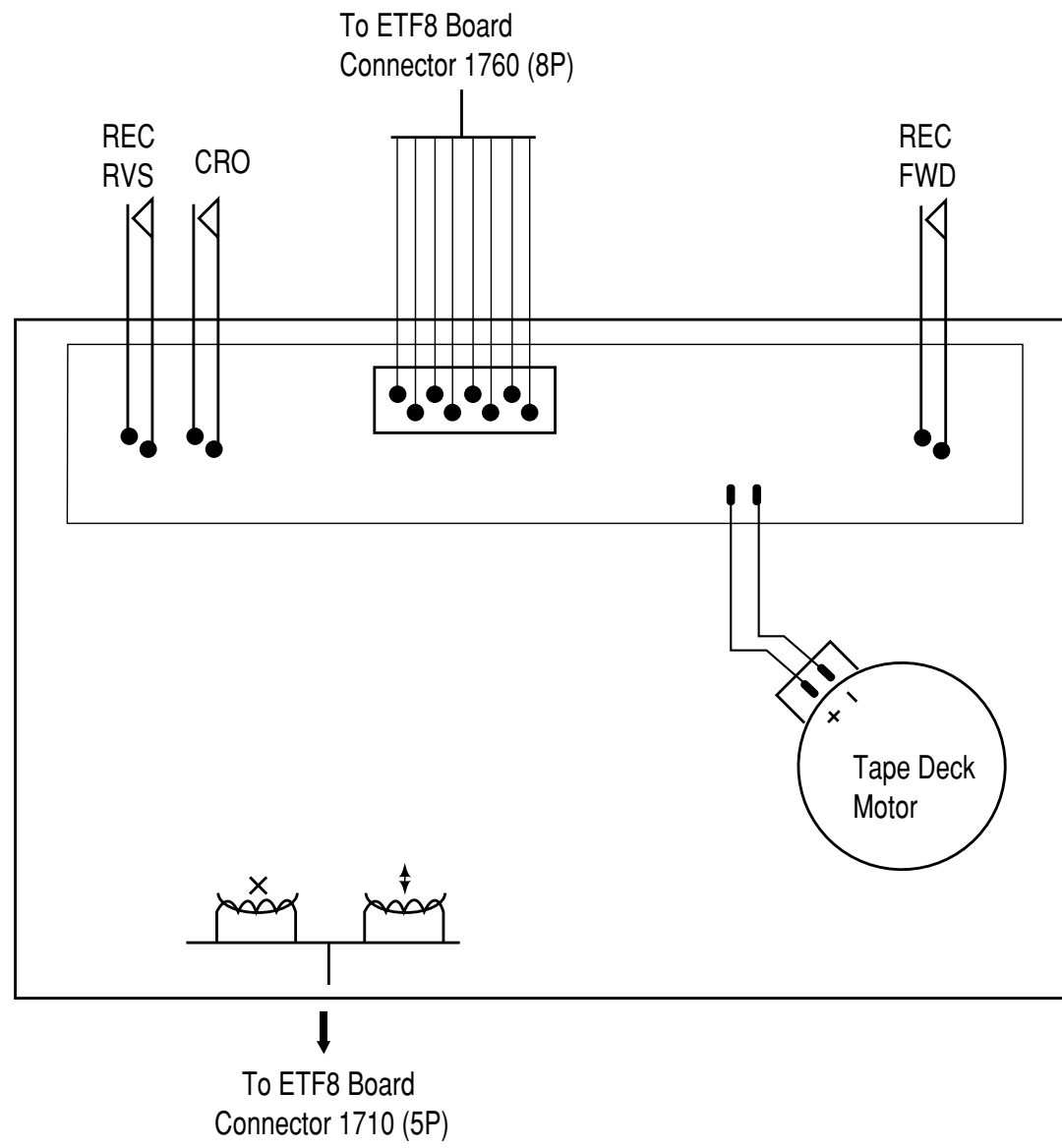

TAPE MECHANISM ELECTRONICS

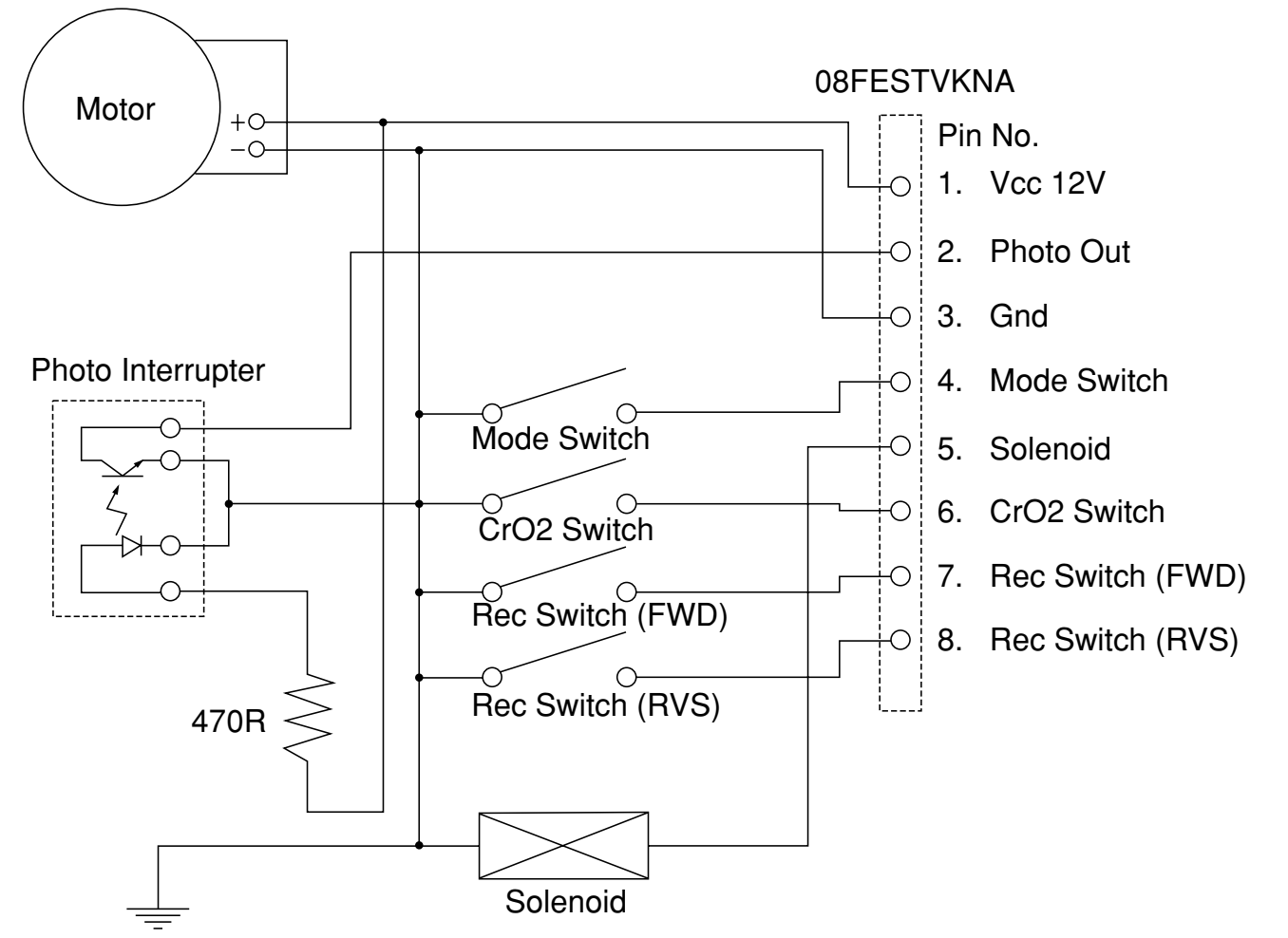

TAPE ADJUSTMENT & CHECK TABLE

	TEST CASSETTE	RECORDER MODE	MEASURE ON	READ ON	ADJUST	
					with	to
MOTOR SPEED	SBC420 3150Hz	PLAY		frequency counter	check	3150Hz +/- 2%
WOW & FLUTTER	SBC420 3150Hz	PLAY		W&F-meter	check	< 0.4 % DIN
ADJUST AZIMUTH	SBC420 10kHz	PLAY FWD	1 or 2 LEFT RIGHT	mV-meter	left hand screw	max. output level & left=right
		PLAY REV ^			right hand screw	
PLAYBACK FREQ. RESPONSE	SBC420	PLAY		mV-meter	check	limits see fig. 1 *
CHECK RECORD/PLAYBACK FREQUENCY AND DISTORTION						
Inject 8.85mV signals 100Hz, 250Hz, 1kHz, 10kHz, 12.5kHz via 3 or 4	SBC419A or SBC420	RECORD				
	RECORDED CASSETTE	PLAY	1 or 2 LEFT RIGHT	mV-meter	check	limits see fig. 2 *
Inject 1kHz 28mV via 3 or 4	SBC419A or SBC420	RECORD				
	RECORDED CASSETTE	PLAY	1 or 2 LEFT RIGHT	THD-meter	check	< 3% *

SBC419A : 4822 397 30069
SBC420 : 4822 397 30071

^ For Auto-reverse version only
* If high frequencies are not within limits, decrease bias and re-measure.
If distortion is too high, increase bias and re-measure

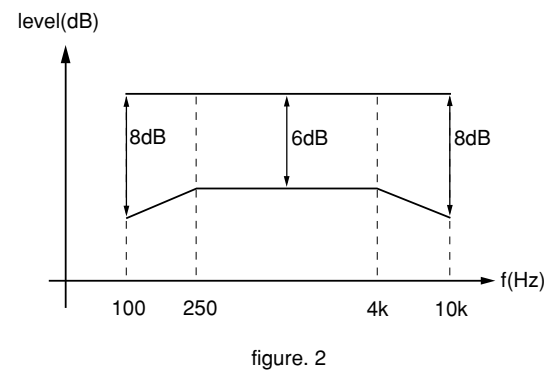
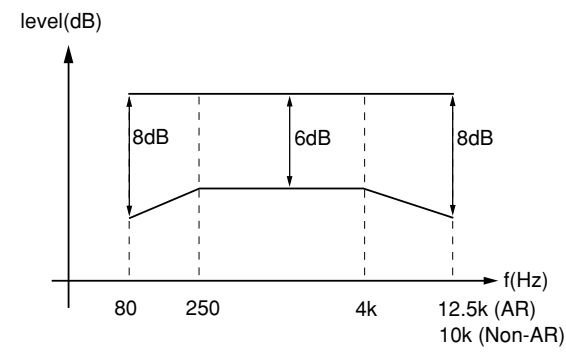

HEF4094BT FUNCTIONAL BLOCK DIAGRAM

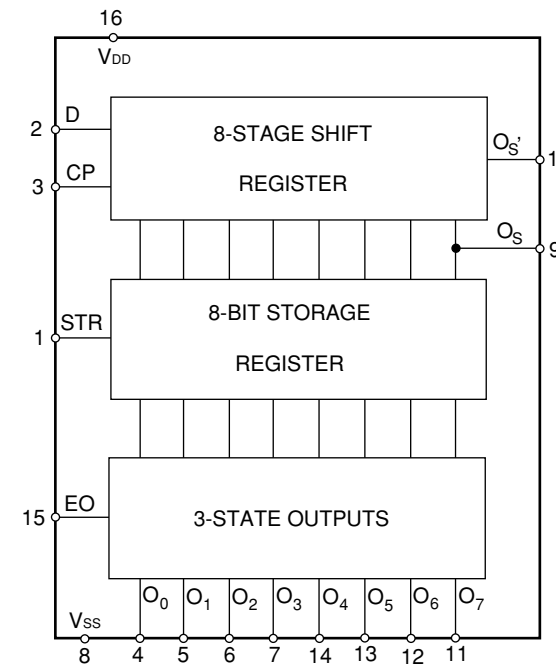

AF Control Logic State Table

State of Module	Control lines from HEF4094BT							
	O ₀	O ₁	O ₂	O ₃	O ₄	O ₅	O ₆	O ₇
	CR_SEL	REC	BIAS_OFF	CR_BIAS		SOL	MUTE_OFF	MOT
Stop	0	0	1	X	Not in used	Deck Mechanism Timing	0	0
Playback (Ferro)	0	0	1	0			1	1
Playback (Chrome)	1	0	1	1			1	1
Record (Ferro)	0	1	0	0			0	1
Record (Chrome)	1	1	0	1			0	1
FWD	0	0	1	X			0	1
REW	0	0	1	X			0	1

Note: 0 = Logic Low
1 = Logic High
X = Not applicable

COMPONENT LAYOUT

1701 A2	2715 A3	2795 A2	6612 A1	6777 B2	9704 A3
1703 A1	2716 A3	2796 B2	6770 B2	6778 B2	9705 A3
1706 A1	2761 A2	2797 A2	6771 B2	7782 B3	9706 B3
1710 A3	2768 A2	2798 A2	6772 B3	7786 A3	
1760 A1	2780 B1	3778 B2	6773 A3	9701 B2	
2713 A3	2784 A3	5701 A3	6774 B3	9702 B1	
2714 A2	2785 B2	5703 B3	6776 B2	9703 A3	

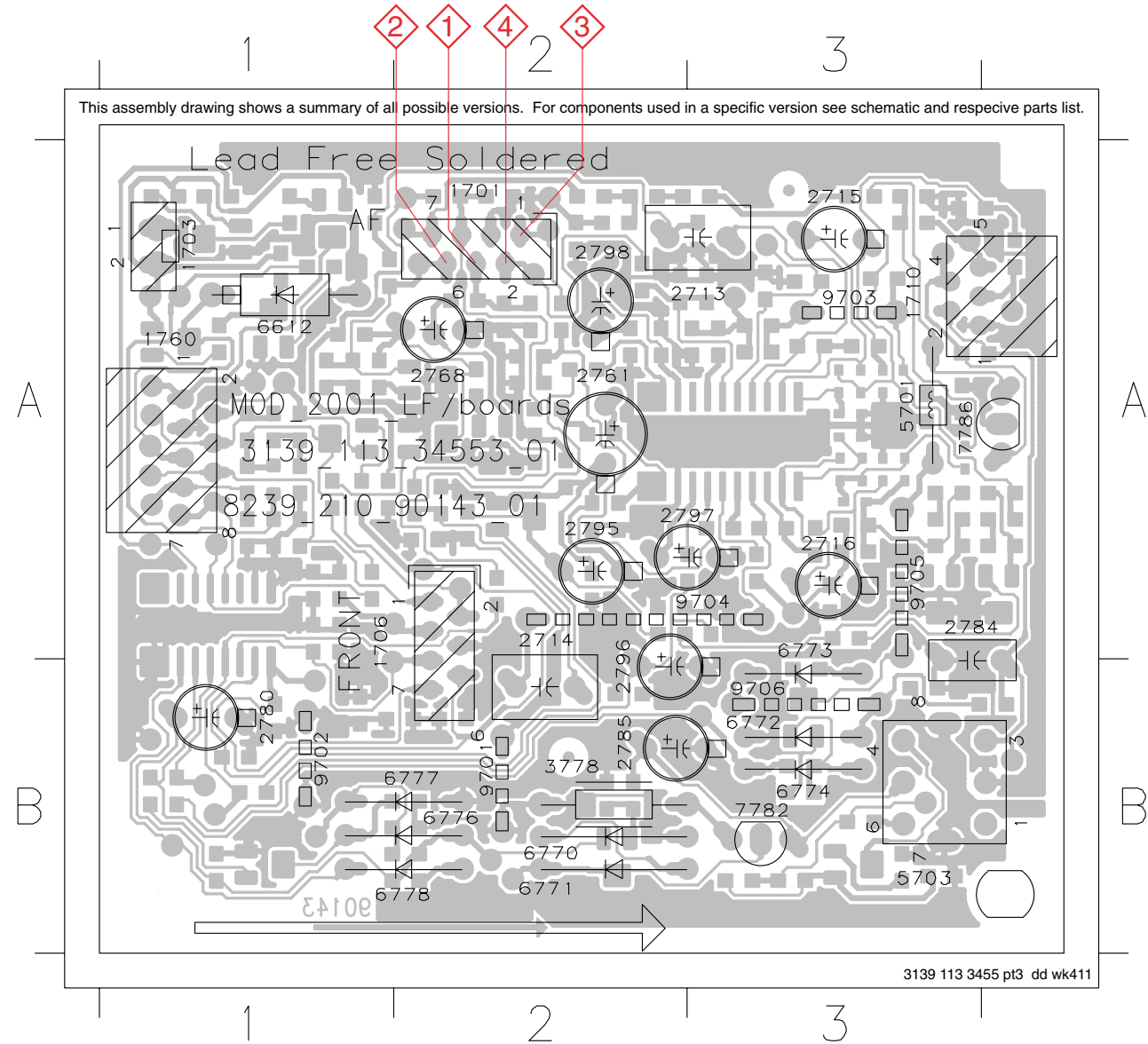

CHIP LAYOUT

2621 B3	2732 A1	3630 A3	3745 A3	3796 A2	4735 A2
2622 B3	2743 B1	3678 A3	3746 A3	3797 A3	4736 A1
2623 A3	2747 A2	3680 A3	3749 A1	3800 B3	4737 A1
2625 A3	2769 A2	3686 A3	3750 A1	4701 A2	4738 A1
2701 A1	2770 A3	3709 A1	3762 B2	4702 A3	4739 A1
2702 A1	2781 B1	3710 A1	3764 A2	4705 A2	4741 A2
2703 A2	2782 B1	3711 A1	3768 A2	4707 B2	4746 A1
2704 A2	2786 B1	3712 A1	3769 B2	4708 A2	4747 A1
2709 A1	2787 B1	3717 A1	3770 B2	4709 A3	7610 A3
2710 A1	2788 A2	3718 A1	3771 B2	4710 A3	7612 A3
2711 A1	2789 A1	3719 A1	3772 B3	4711 A3	7614 A3
2712 A2	2790 A1	3720 A1	3774 B2	4712 A3	7618 A3
2717 A1	2791 A1	3721 A1	3775 B1	4718 A2	7620 A3
2718 A1	2793 A1	3722 A1	3776 B1	4719 A2	7624 A3
2719 A1	2794 A1	3723 A1	3777 B1	4720 A2	7720 A1
2720 A1	2799 A2	3724 A1	3779 B1	4721 B2	7780 B3
2721 A1	3607 A3	3733 A2	3780 B1	4723 A2	7781 B1
2722 A1	3608 A3	3734 A1	3781 A1	4725 A2	7783 B2
2723 A1	3609 A3	3735 A2	3786 B3	4726 A2	7784 B1
2724 A1	3610 A3	3736 A2	3789 B2	4727 B3	7788 A2
2725 A3	3611 A3	3737 A2	3790 A2	4729 A1	7789 A2
2727 A1	3612 A3	3738 A3	3791 A1	4730 A1	7790 A2
2728 A1	3614 A3	3739 A3	3792 B3	4731 B2	7792 A2
2729 A1	3624 A3	3740 A3	3793 A2	4732 A2	7793 A1
2730 A1	3626 A3	3743 A2	3794 A1	4733 A2	7794 A1
2731 A1	3628 A3	3744 A3	3795 A1	4734 A2	

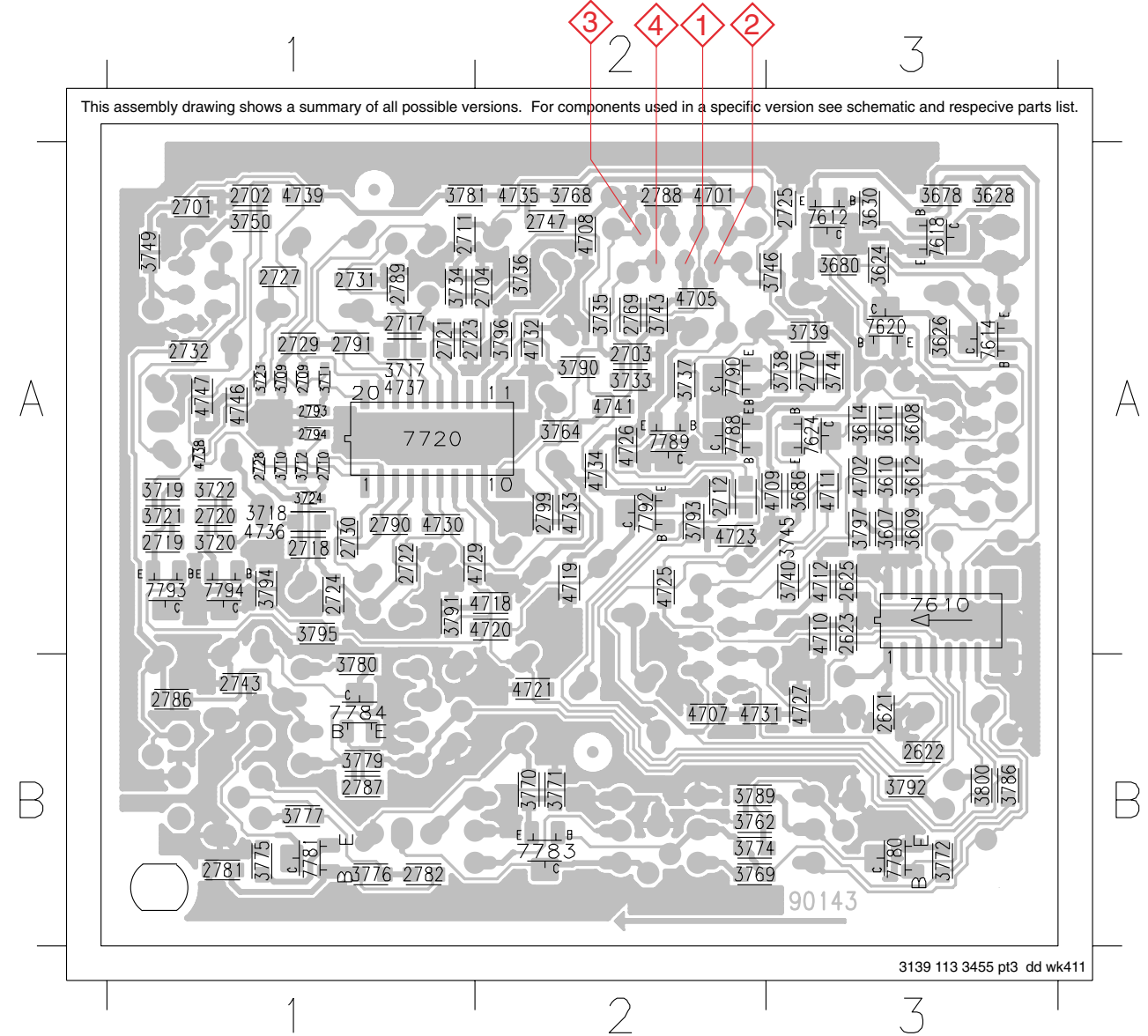

CIRCUIT DIAGRAM

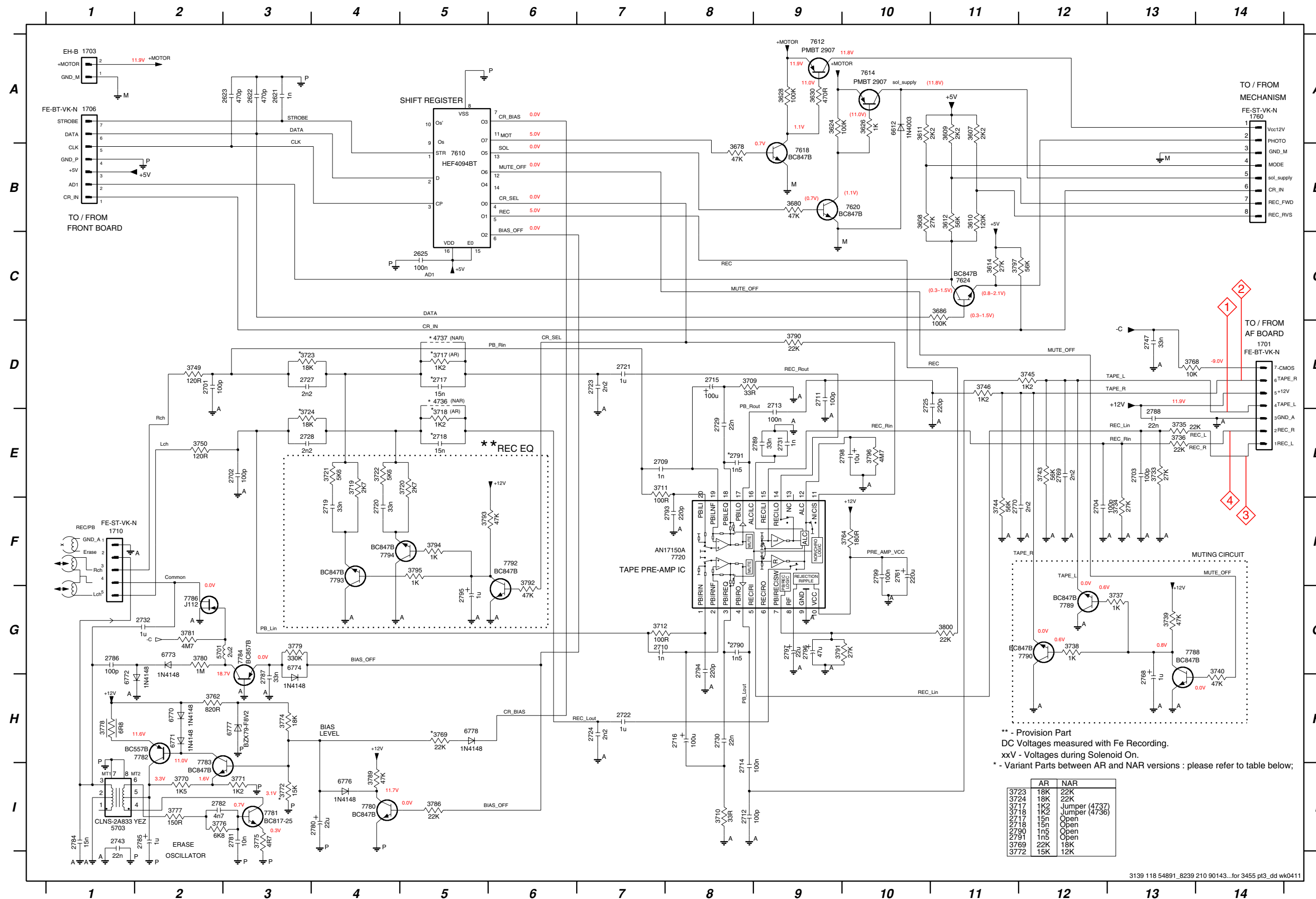

** - Provision Part
 DC Voltages measured with Fe Recording.
 xxV - Voltages during Solenoid On.
 * - Variant Parts between AR and NAR versions : please refer to table below;

	AR	NAR
3723	18K	22K
3724	18K	22K
3717	1K2	Jumper (4737)
3718	1K2	Jumper (4736)
2717	15n	Open
3718	15n	Open
3730	1n5	Open
2791	1n5	Open
3769	22K	18K
3772	15K	12K

- 1701 D14
- 1703 A1
- 1706 A1
- 1710 F1
- 1760 A14
- 2621 A3
- 2622 A3
- 2623 A3
- 2625 C5
- 2701 D2
- 2702 E3
- 2703 E13
- 2704 F12
- 2709 E7
- 2710 G7
- 2711 D9
- 2712 B8
- 2713 D9
- 2714 B8
- 2715 D8
- 2716 H8
- 2717 D5
- 2718 E5
- 2719 F4
- 2720 F4
- 2721 D7
- 2722 H7
- 2723 D7
- 2724 H7
- 2725 D10
- 2727 D3
- 2728 E3
- 2729 E8
- 2730 H8
- 2731 E9
- 2732 G2
- 2743 I1
- 2747 D13
- 2761 F10
- 2768 H13
- 2769 E12
- 2770 F11
- 2780 A4
- 2781 I3
- 2782 I2
- 2784 I1
- 2785 I2
- 2786 G1
- 2787 H3
- 2788 E13
- 2789 E9
- 2790 G8
- 2791 E8
- 2793 F8
- 2794 G8
- 2795 G5
- 2796 G9
- 2797 G9
- 2798 E9
- 2799 F10
- 3607 A11
- 3608 B10
- 3609 A11
- 3610 B11
- 3611 A10
- 3612 B11
- 3614 C11
- 3624 A9
- 3626 A10
- 3628 A9
- 3630 A9
- 3678 B8
- 3680 B9
- 3686 C11
- 3709 D8
- 3710 I8
- 3711 E7
- 3712 G7
- 3717 D5
- 3718 E5
- 3719 E4
- 3720 E5
- 3721 E4
- 3722 E4
- 3723 D3
- 3724 E3
- 3733 E13
- 3734 F13
- 3735 E13
- 3736 E13
- 3737 G13
- 3738 G12
- 3739 G13
- 3740 G14
- 3743 E12
- 3744 F11
- 3745 D12
- 3746 D11
- 3749 D2
- 3750 E2
- 3762 H2
- 3764 F10
- 3768 D13
- 3769 H5
- 3770 I2
- 3771 I2
- 3772 I3
- 3774 H3
- 3775 I3
- 3776 I2
- 3777 I2
- 3778 H1
- 3779 G3
- 3780 G2
- 3781 G2
- 3786 I5
- 3789 I4
- 3790 D9
- 3791 G9
- 3793 F5
- 3794 F5
- 3795 F5
- 3796 E10
- 3797 C11
- 3800 G11
- 4736 D5
- 4737 D5
- 5701 G2
- 5703 I1
- 6612 A10
- 6770 H2
- 6771 H2
- 6772 H1
- 6773 G2
- 6774 G3
- 6776 I4
- 6777 H3
- 6778 H5
- 6780 H2
- 6781 H2
- 6782 H2
- 6783 I2
- 6784 G3
- 6788 G14
- 6789 G12
- 6790 G12
- 6792 F6
- 6793 F4
- 6794 F4

AUTOREVERSE (AR) TAPE MECHANISM

MECHANICAL PARTS LIST - AUTOREVERSE TAPE MECHANISM

1	9965 000 10041	Rec/Pb Head assembly
7	9965 000 10042	Cap Pinch R
8	9965 000 10043	Cap Pinch L
9	9965 000 10044	Roller Pinch
32	9965 000 10045	Solenoid assembly
34	9965 000 10046	Motor Assembly
36	9965 000 07441	Belt-SR
37	9965 000 07442	Belt-FR
39	9965 000 10047	Flex Socket 5pin Hort.
40-2	9965 000 10048	Flex Socket 8pin Hort.
40-3	9965 000 10049	Mode Switch
40-4	4822 116 83883	470R 5% 0,5W
40-5	9965 000 10050	Spacer
40-6	9965 000 10051	Photo Interrupter
40-7	9965 000 07443	Box Switch
40-8	9965 000 10052	Spring Sw
61	9965 000 10053	Spring
62	9965 000 10054	Spring

Note: Only the parts mentioned in this list are normal service spare parts.

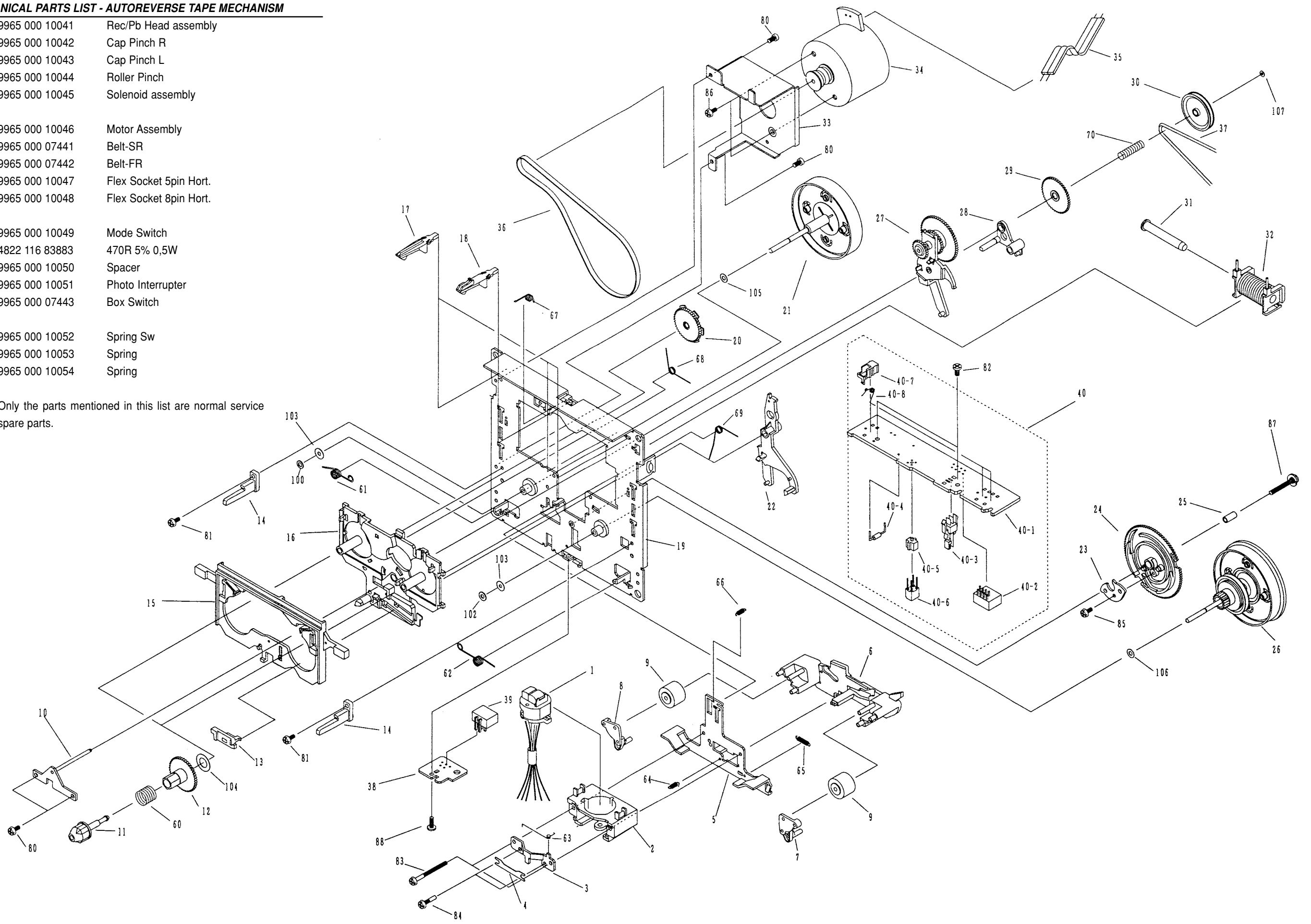

NON-AUTOREVERSE (NAR) TAPE MECHANISM

MECHANICAL PARTS LIST - NON-AUTOREVERSE TAPE MECHANISM

1	9965 000 12110	Play Head
2	9965 000 02600	Erase Head
7	9965 000 10042	Cap Pinch Roller
9	9965 000 10044	Roller Pinch
32	9965 000 07439	Solenoid Assy
34	9965 000 10046	Assembly Motor
36	9965 000 12114	Belt SF
37	9965 000 07442	Belt FR
39	9965 000 12115	Flex Socket 5pin Hort.
40-2	4822 265 11535	Flex Socket 8pin Hort.
40-3	9965 000 10049	Mode Switch
40-4	4822 116 83883	470R 5% 0,5W
40-5	9965 000 12116	Spacer
40-6	9965 000 10051	Photo Interrupter
40-7	9965 000 07443	Box Switch
40-8	9965 000 10052	Spring Sw
61	9965 000 10053	Spring
62	9965 000 10054	Spring

Note: Only the parts mentioned in this list are normal service spare parts.

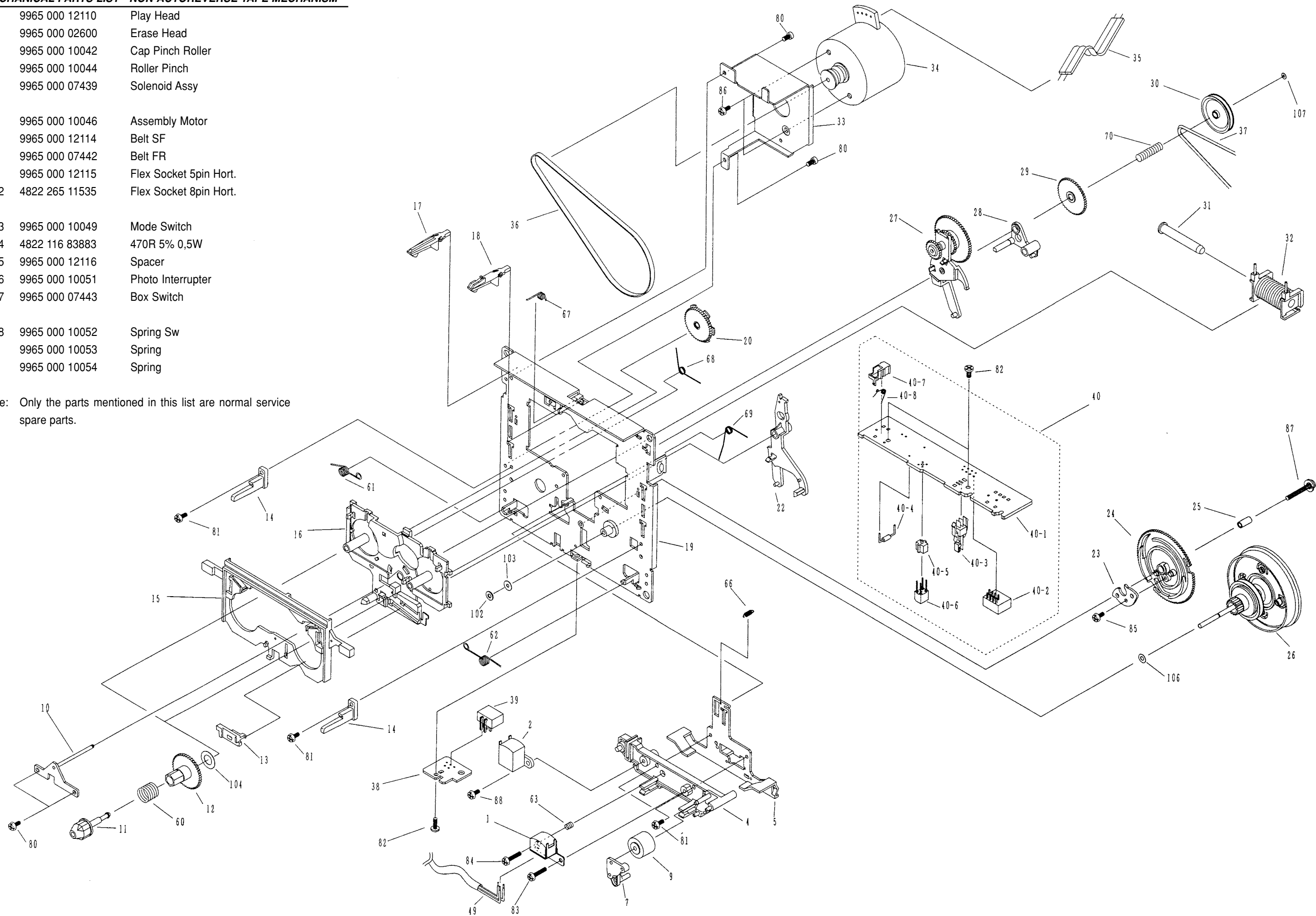

TAPE MODULE EXPLODED VIEW

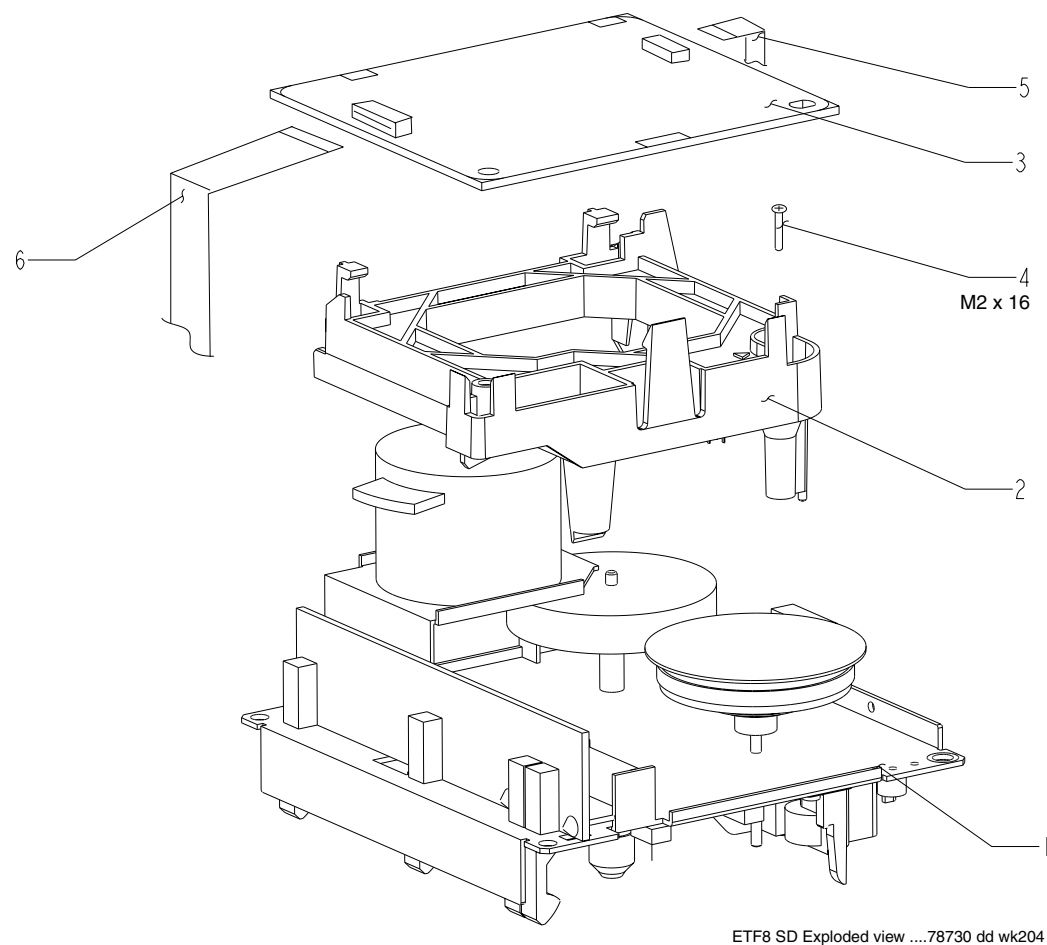

MECHANICAL PARTS LIST - TAPE MODULE

1	3139 118 78740	AR Tape Mech. CRL4438
1	3139 118 79220	Non-AR Tape Mech. CFL4217
5	3139 110 35580	Flex Cable 5pin 40mm AD
6	3139 110 35590	Flex Cable 8pin 48mm AD

Note: Only the parts mentioned in this list are normal service spare parts.

ELECTRICAL PARTS LIST - ETF8 BOARD

MISCELLANEOUS

1701	4822 267 10953	Flex Socket 7pin Vert.
1706	4822 267 10953	Flex Socket 7pin Vert.
1710	4822 267 10958	Flex Socket 5pin Hort.
1760	4822 265 11535	Flex Socket 8pin Hort.

CAPACITORS

2621	5322 126 11578	1nF 10% 50V
2621	5322 122 31647	1nF 10% 63V
2622	4822 126 13881	470pF 5% 50V
2622	5322 122 32268	470pF 5% 50V
2623	4822 126 13881	470pF 5% 50V
2623	5322 122 32268	470pF 5% 50V
2625	4822 126 14305	100nF 10% 16V
2625	2238 586 59812	100nF +80/-20% 50V
2701	4822 122 31765	100pF 2% 63V
2701	5322 122 32531	100pF 5% 50V
2702	4822 122 31765	100pF 2% 63V
2702	5322 122 32531	100pF 5% 50V
2703	4822 122 31765	100pF 2% 63V
2703	5322 122 32531	100pF 5% 50V
2704	4822 122 31765	100pF 2% 63V
2704	5322 122 32531	100pF 5% 50V
2709	5322 126 11578	1nF 10% 50V
2710	5322 126 11578	1nF 10% 50V
2711	4822 122 31765	100pF 2% 63V
2711	5322 122 32531	100pF 5% 50V
2712	4822 122 31765	100pF 2% 63V
2712	5322 122 32531	100pF 5% 50V
2713	5322 121 42386	100nF 5% 63V
2714	5322 121 42386	100nF 5% 63V
2715	4822 124 41584	100uF 20% 10V
2716	4822 124 41584	100uF 20% 10V
2717	3198 017 31530	15nF 50V
2717	4822 126 13188	15nF 5% 63V
2718	3198 017 31530	15nF 50V
2718	4822 126 13188	15nF 5% 63V
2721	3198 017 41050	1uF 10V
2721	4822 126 14043	1uF +80/-20% 16V
2722	3198 017 41050	1uF 10V
2722	4822 126 14043	1uF +80/-20% 16V
2723	4822 126 14238	2,2nF 50V
2724	4822 126 14238	2,2nF 50V
2725	4822 126 13883	220pF 5% 50V
2727	4822 126 14238	2,2nF 50V
2728	4822 126 14238	2,2nF 50V
2729	4822 126 14494	22nF 10% 25V
2729	2238 916 15641	22nF 10% 25V
2730	4822 126 14494	22nF 10% 25V
2730	2238 916 15641	22nF 10% 25V
2731	5322 126 11578	1nF 10% 50V
2731	5322 122 31647	1nF 10% 63V
2732	3198 017 41050	1uF 10V

2732	4822 126 14043	1uF +80/-20% 16V
2743	4822 126 14494	22nF 10% 25V
2743	2238 916 15641	22nF 10% 25V
2747	4822 126 14549	33nF 16V
2761	4822 124 40196	220uF 20% 16V
2768	4822 124 40756	1uF 20% 100V
2769	4822 126 14238	2,2nF 50V
2770	4822 126 14238	2,2nF 50V
2780	4822 124 81151	22uF 50V
2781	5322 126 11583	10nF 10% 50V
2781	4822 122 33177	10nF 20% 50V
2782	4822 126 13193	4,7nF 10% 63V
2784	4822 121 51305	15nF 10% 50V
2785	4822 124 21913	1uF 20% 63V
2786	4822 122 31765	100pF 2% 63V
2786	5322 122 32531	100pF 5% 50V
2787	4822 126 14549	33nF 16V
2788	4822 126 14494	22nF 10% 25V
2788	2238 916 15641	22nF 10% 25V
2789	4822 126 14549	33nF 16V
2790	4822 126 14247	1,5nF 50V
2791	4822 126 14247	1,5nF 50V
2793	4822 126 13883	220pF 5% 50V
2794	4822 126 13883	220pF 5% 50V
2796	4822 124 40433	47uF 20% 25V
2797	4822 124 81151	22uF 50V
2798	4822 124 21732	10uF 20% 25V
2799	4822 126 14305	100nF 10% 16V
2799	2238 586 59812	100nF +80/-20% 50V

RESISTORS

3607	4822 051 30222	2k2 5% 0,062W
3607	4822 117 11449	2k2 5% 0,1W
3608	4822 051 30273	27k 5% 0,062W
3609	4822 051 30222	2k2 5% 0,062W
3609	4822 117 11449	2k2 5% 0,1W
3610	4822 051 20124	120k 5% 0,1W
3611	4822 051 30222	2k2 5% 0,062W
3611	4822 117 11449	2k2 5% 0,1W
3612	4822 051 30563	56k 5% 0,062W
3614	4822 051 30273	27k 5% 0,062W
3624	4822 117 13632	100k 1% 0,062W
3624	4822 117 10837	100k 1% 0,1W
3626	4822 051 30102	1k 5% 0,062W
3628	4822 117 13632	100k 1% 0,062W
3628	4822 117 10837	100k 1% 0,1W
3630	4822 051 30471	470R 5% 0,062W
3678	4822 117 12925	47k 1% 0,063W
3680	4822 117 12925	47k 1% 0,063W
3686	4822 117 13632	100k 1% 0,062W
3686	4822 117 10837	100k 1% 0,1W
3709	4822 051 30339	33R 5% 0,062W

AR
AR

ELECTRICAL PARTS LIST - ETF8 BOARD

RESISTORS

3710	4822 051 30339	33R 5% 0,062W	
3711	4822 051 30101	100R 5% 0,062W	
3712	4822 051 30101	100R 5% 0,062W	
3717	4822 117 11817	1k2 1% 1/16W	AR
3717	4822 051 20122	1k2 5% 0,1W	AR
3718	4822 117 11817	1k2 1% 1/16W	AR
3718	4822 051 20122	1k2 5% 0,1W	AR
3723	4822 051 30183	18k 5% 0,062W	AR
3723	4822 051 30223	22k 5% 0,062W	Non-AR
3724	4822 051 30183	18k 5% 0,062W	AR
3724	4822 051 30223	22k 5% 0,062W	Non-AR
3733	4822 051 30273	27k 5% 0,062W	
3734	4822 051 30273	27k 5% 0,062W	
3735	4822 051 30223	22k 5% 0,062W	
3735	4822 051 20223	22k 5% 0,1W	
3736	4822 051 30223	22k 5% 0,062W	
3736	4822 051 20223	22k 5% 0,1W	
3737	4822 051 30102	1k 5% 0,062W	
3737	4822 051 10102	1k 2% 0,25W	
3738	4822 051 30102	1k 5% 0,062W	
3738	4822 051 10102	1k 2% 0,25W	
3739	4822 117 12925	47k 1% 0,063W	
3740	4822 117 12925	47k 1% 0,063W	
3743	4822 051 30563	56k 5% 0,062W	
3744	4822 051 30563	56k 5% 0,062W	
3745	4822 117 11817	1k2 1% 1/16W	
3745	4822 051 20122	1k2 5% 0,1W	
3746	4822 117 11817	1k2 1% 1/16W	
3746	4822 051 20122	1k2 5% 0,1W	
3749	4822 051 30121	120R 5% 0,062W	
3749	4822 051 20121	120R 5% 0,1W	
3750	4822 051 30121	120R 5% 0,062W	
3750	4822 051 20121	120R 5% 0,1W	
3762	4822 117 12968	820R 5% 0,62W	
3764	4822 051 30181	180R 5% 0,062W	
3764	4822 117 11448	180R 1% 0,1W	
3768	4822 051 30103	10k 5% 0,062W	
3768	4822 117 10833	10k 1% 0,1W	
3769	4822 051 30223	22k 5% 0,062W	AR
3769	4822 051 30183	18k 5% 0,062W	Non-AR
3770	4822 051 30152	1k5 5% 0,062W	
3771	4822 117 11817	1k2 1% 1/16W	
3771	4822 051 20122	1k2 5% 0,1W	
3772	4822 051 30153	15k 5% 0,062W	AR
3772	4822 051 30123	12k 5% 0,062W	Non-AR
3774	4822 051 30183	18k 5% 0,062W	
3775	4822 117 13608	4,7R 5% 0,063W	
3776	4822 051 30682	6k8 5% 0,062W	
3777	4822 051 30151	150R 5% 0,062W	
3777	4822 117 10353	150R 1% 0,1W	
3778	4822 052 10688	6R8 5% 0,33W	
3779	4822 051 30334	330k 5% 0,062W	

3780	4822 051 30105	1M 5% 0,062W	
3780	4822 051 20105	1M 5% 0,1W	
3781	4822 051 30475	4M7 5% 0,062W	
3786	4822 051 30223	22k 5% 0,062W	
3786	4822 051 20223	22k 5% 0,1W	
3789	4822 117 12925	47k 1% 0,063W	
3790	4822 051 30223	22k 5% 0,062W	
3790	4822 051 20223	22k 5% 0,1W	
3791	4822 051 30273	27k 5% 0,062W	
3796	4822 051 30475	4M7 5% 0,062W	
3797	4822 051 30563	56k 5% 0,062W	
3800	4822 051 30223	22k 5% 0,062W	
3800	4822 051 20223	22k 5% 0,1W	
4701	4822 051 30008	0R Jumper 0603	
4702	4822 051 30008	0R Jumper 0603	
4705	4822 051 30008	0R Jumper 0603	
4707	4822 051 30008	0R Jumper 0603	
4708	4822 051 30008	0R Jumper 0603	
4709	4822 051 30008	0R Jumper 0603	
4710	4822 051 30008	0R Jumper 0603	
4711	4822 051 30008	0R Jumper 0603	
4712	4822 051 30008	0R Jumper 0603	
4718	4822 051 30008	0R Jumper 0603	
4719	4822 051 30008	0R Jumper 0603	
4720	4822 051 30008	0R Jumper 0603	
4721	4822 051 30008	0R Jumper 0603	
4723	4822 051 30008	0R Jumper 0603	
4725	4822 051 30008	0R Jumper 0603	
4726	4822 051 30008	0R Jumper 0603	
4727	4822 051 30008	0R Jumper 0603	
4729	4822 051 30008	0R Jumper 0603	
4730	4822 051 30008	0R Jumper 0603	
4731	4822 051 30008	0R Jumper 0603	
4732	4822 051 30008	0R Jumper 0603	
4733	4822 051 30008	0R Jumper 0603	
4734	4822 051 30008	0R Jumper 0603	
4735	4822 051 30008	0R Jumper 0603	
4736	4822 051 30008	0R Jumper 0603	Non-AR
4737	4822 051 30008	0R Jumper 0603	Non-AR
4738	4822 051 30008	0R Jumper 0603	
4739	4822 051 30008	0R Jumper 0603	
4741	4822 051 30008	0R Jumper 0603	
4746	4822 051 30008	0R Jumper 0603	
4747	4822 051 30008	0R Jumper 0603	

COILS & FILTERS

5701	4822 157 62552	Coil 2,2uH 5%
5703	4822 156 20946	Osc Coil 100kHz

DIODES

6612	4822 130 31878	1N4003G
6770	4822 130 30621	1N4148

ELECTRICAL PARTS LIST - ETF8 BOARD

6771	4822 130 30621	1N4148
6772	4822 130 30621	1N4148
6773	4822 130 30621	1N4148
6774	4822 130 30621	1N4148
6776	4822 130 30621	1N4148
6777	4822 130 34382	BZX79-B8V2
6778	4822 130 30621	1N4148

TRANSISTORS & INTEGRATED CIRCUIT

7610	5322 209 11306	HEF4094BT
7612	4822 130 11201	PMBT2907
7614	4822 130 11201	PMBT2907
7618	5322 130 60159	BC847B
7620	5322 130 60159	BC847B
7624	5322 130 60159	BC847B
7720	9322 167 09668	AN17150ATA
7780	5322 130 60159	BC847B
7781	4822 130 42804	BC817-25
7782	4822 130 44568	BC557B
7783	5322 130 60159	BC847B
7784	4822 130 60373	BC857B
7786	9340 052 70126	FET SIG J112
7788	5322 130 60159	BC847B
7789	5322 130 60159	BC847B
7790	5322 130 60159	BC847B

Note: Only the parts mentioned in this list are normal service spare parts.

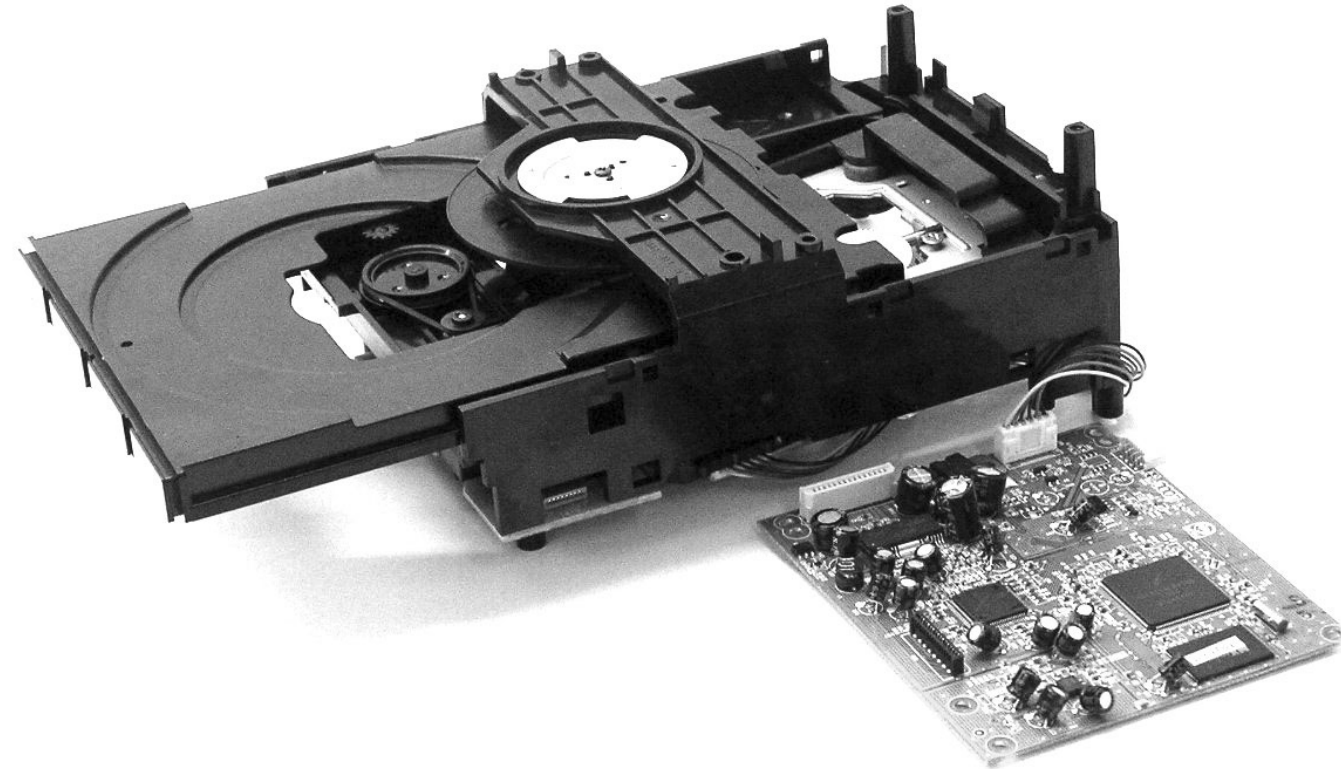

Universal Loader

(Single Disc Tray Loader)

WMA MP3 version

This document describes the version with the Sanyo CD drive **DA11VF**.
 The CD drive used in a specific application is stated on the type plate, located on one of the side walls of the changer module.

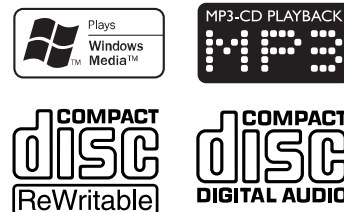

TABLE OF CONTENTS

Service Hints10-1
 Pin description10-3
 IC Block Diagram10-4
 Block Diagram10-5
 Tray-motor Board10-6
 Circuit Diagram CD Main Board10-7 to 10-12
 Layout CD Main Board10-13 to 10-14
 Exploded View..... 10-15
 Partslist10-16

Service hints

In case of symptom „skipping tracks“ perform following actions:

1. VERIFY THE COMPLAINT

PLAYABILITY CHECK

use CD-RW Printed Audio Disk7104 099 96611
 TR 3 (Fingerprint)
 TR 8 (600µ black dot) **maximum at 01:00**

- playback of these two tracks without audible disturbance playing time for: Fingerprint ≥10seconds
 Black dot from 00:50 to 01:10
- jump forward/backward (search) within a reasonable time

2. CLEAN THE LENS

CD DRIVE – LENS CLEANING

Before touching the lens it is advised to clean the surface of the lens by blowing clean air over it in order to avoid that little particles make scratches on the lens.

Because the material of the lens is synthetic and coated with a special anti-reflectivity layer, cleaning must be done with a non-aggressive cleaning fluid. It is advised to use “Cleaning Solvent B4”, available with codenumber 4822 389 10026.

The actuator is a very precise mechanical component and may not be damaged in order to guarantee its full function. It is advised to clean the lens gently (don't press too hard) with a soft and clean cotton bud moistened with the special lens cleaner.

The direction of cleaning must be in the way as indicated in the picture below.

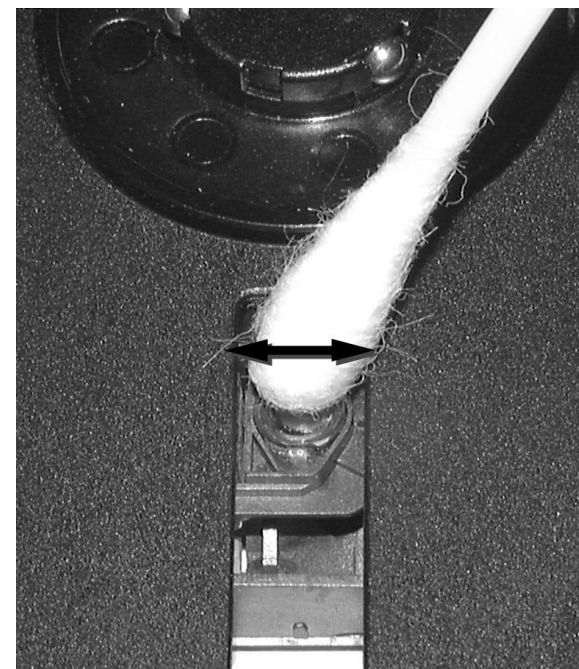

3. MEASURE THE LASER CURRENT

CD DRIVE – LASER CURRENT MEASUREMENT

The laser current can be measured as a voltage drop on resistor 3822. Typical value 55mV (DA11 disc drive).

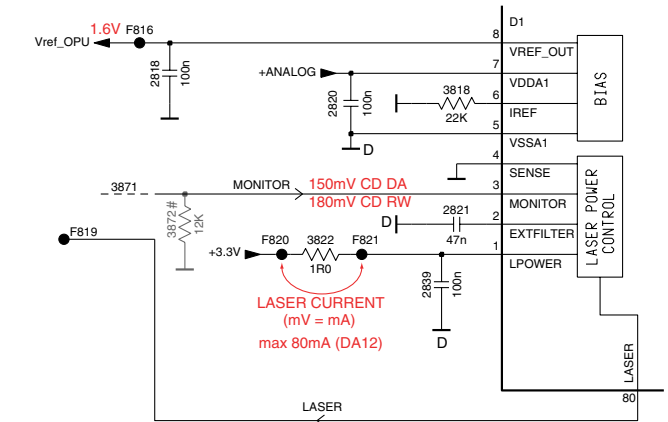

If the value is higher than 80mV (DA11 disc drive) or the current increases just after switching the laser on - the laserdiode is most probably defective. In that case the CD drive has to be replaced.

4. GENERAL HINTS

Since the HF pre-amplifier is integrated into the new "CD18" signal processor the well-known eye pattern signal is not available as external signal and cannot be measured anymore. Also measuring the offset voltages is not necessary because the new signal processor contains an automatic offset compensation.

However the circuitry offers some new aspects for checking the system:

- the Monitor voltage shows if the sensitivity is set correctly (attention: ESD sensitive line!):
 CD DA: 150mV
 CD RW: 180mV
- the Focus search algorithm is divided into 4 steps:
 1st step: CD DA sensitivity
 2nd step: CD DA enforced sensitivity
 3rd step: CD RW sensitivity
 4th step: CD RW enforced sensitivity

The used sensitivity can be found out by either measuring the Monitor voltage or counting the up/down movements of the OPU until focus is found.
 e.g. when a normal CD DA is played back Monitor voltage should measure 150mV respectively Focus should be found within the first up/down movement of the OPU.

- In case a higher sensitivity setting can be observed than defined, there are following possible reasons:
- disc scratched or dirty
 - poor reflectivity of the disc - disc not conform standard
 - lens of the OPU dirty
 - laser power too low

CAUTION

CHARGED CAPACITORS ON THE SERVO BOARD MAY DAMAGE THE CD DRIVE ELECTRONICS WHEN CONNECTING A NEW CD MECHANISM. THAT'S WHY, BESIDES THE SAFETY MEASURES LIKE

- **SWITCH OFF POWER SUPPLY**
- **ESD PROTECTION**

ADDITIONAL ACTIONS MUST BE TAKEN BY THE REPAIR TECHNICIAN.

The following steps have to be done when replacing the CD mechanism:

1. Disconnect flexfoil cable from the old CD drive
2. Put a paperclip onto the flexfoil cable to short-circuit the contacts (fig.1)
3. Remove the old CD drive
4. Remove paperclip from the flexfoil cable and connect it to the new CD drive
5. Position the new CD drive on its studs
6. Remove solder joint from the Laser unit (see below)

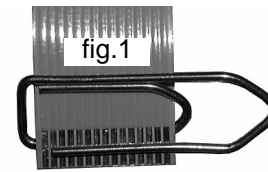

Attention: The laser diode of this CD drive is protected against ESD by a solder joint which short-circuits the laser diode to ground.
For proper functionality of the CD drive this solder joint must be removed **after** connecting the drive to the set.

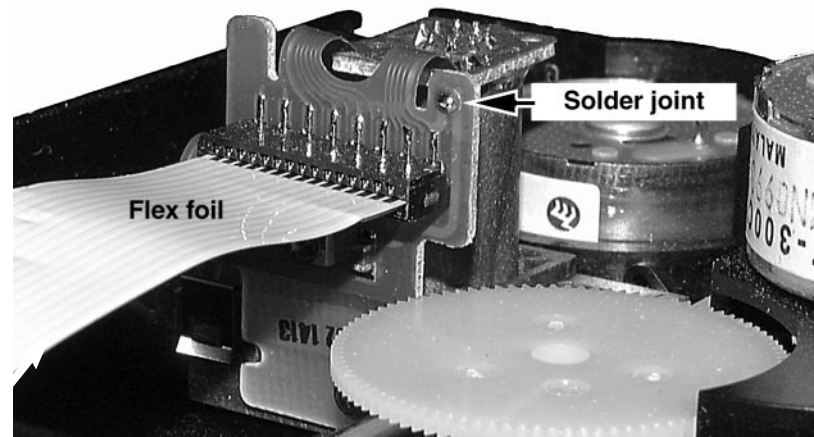

Emergency open

- In case of a Supply fault, the drawer can be opened manually.
1. Remove the top cover of the set to get access to the CD Module.
 2. Proceed as shown in picture below.

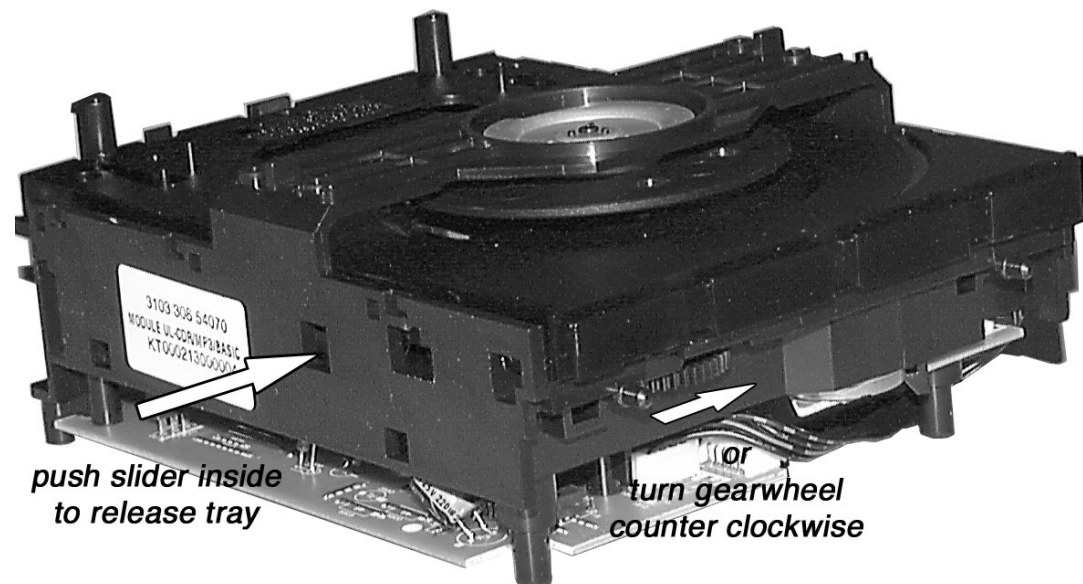

Dismantling of Drawer

1. Open the drawer and release 2 catches as shown in fig. 2
2. Pull drawer out.

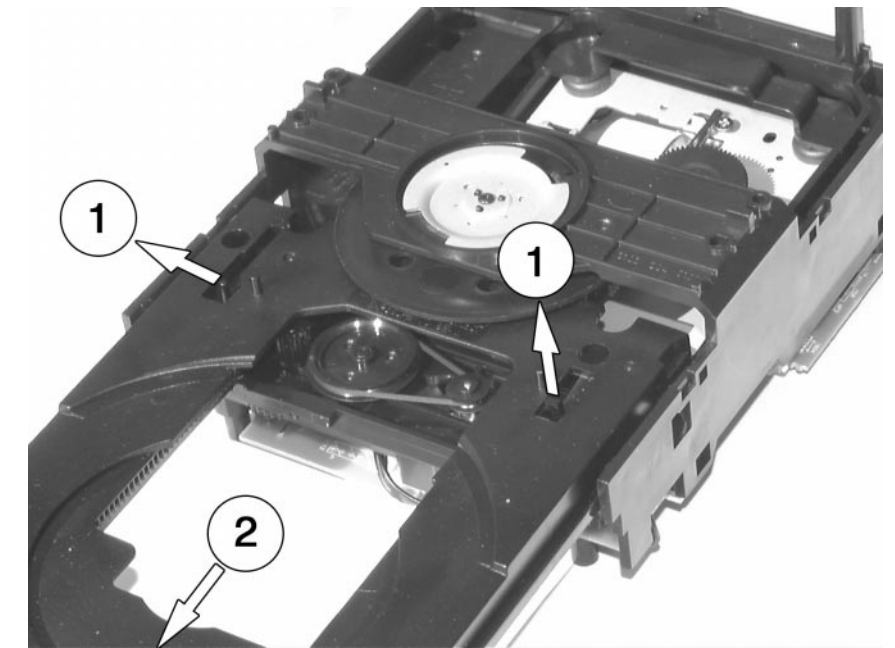
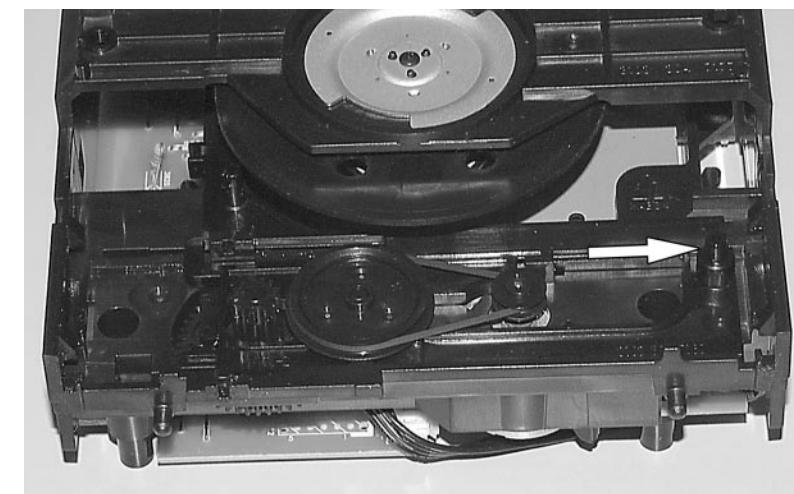

fig.2

Assembling of Drawer

1. Check if slider is on the right side → see picture below.
2. If necessary - move slider to the right end position first.
3. Insert the Drawer.



PIN DESCRIPTION

CD AUDIO DECODER - SAA7824

SYMBOL	PIN	DESCRIPTION
LPOWER	1	Laser power supply
EXTFILTER	2	10 nF capacitor for Laser start-up control
MONITOR	3	Laser monitor diode
SENSE	4	OPU ground reference point for MONITOR measurement
V _{SSA1}	5	Analogue ground 1
IREF	6	Reference current pin (24KΩ resistor to analogue ground)
V _{DDA1}	7	Analogue supply voltage 1
VREF_OUT	8	Servo reference voltage
D1	9	Diode voltage/current input (central diode signal input)
D2	10	Diode voltage/current input (central diode signal input)
D3	11	Diode voltage/current input (central diode signal input)
D4	12	Diode voltage/current input (central diode signal input)
R1	13	Diode voltage/current input (satellite diode signal input)
R2	14	Diode voltage/current input (satellite diode signal input)
CSLICE	15	10nF capacitor for adaptive HF dataslicer
V _{DDA2}	16	Analogue supply voltage 2
V _{SSA2}	17	Analogue ground 2
OSCOUT	18	Crystal/resonator output
OSCIN	19	Crystal/resonator input
V _{SSA3}	20	Analogue ground 3
DAC_GND	21	Audio DAC ground
DAC_RP	22	Audio DAC right channel differential output (positive)
DAC_RN	23	Audio DAC right channel differential output (negative)
DAC_VREF	24	Audio DAC decoupling point (10uF//100nF to ground)
DAC_LN	25	Audio DAC left channel differential output (negative)
DAC_LP	26	Audio DAC left channel differential output (positive)
DAC_VPOS	27	Audio DAC positive supply
BUF_VPOS	28	Audio buffer positive supply
BUF_IN_R	29	Audio buffer right input
BUF_OUT_R	30	Audio buffer right output
BUF_OUT_L	31	Audio buffer left output
BUF_IN_L	32	Audio buffer left input
BUF_GND	33	Audio buffer ground
LKILL	34	Kill output for left channel (configurable as open drain)
RKILL	35	Kill output for right channel (configurable as open drain)
CDT_RDY	36	CD-Text to micro ready flag
CDT_DATA	37	CD-Text data to micro
CDT_CLK	38	CD-Text micro clock
CFLAG	39	Correction flag output (open drain)
V _{SSD1}	40	Digital ground 1
V _{DD1}	41	Digital supply voltage 1
SDI	42	Serial data input (loopback)
WCLI	43	Word clock input (loopback)

SYMBOL	PIN	DESCRIPTION
SCLI	44	Serial bit clock (loopback)
EF	45	C2 error flag
DATA	46	Serial data output
WCLK	47	Word clock output
SCLK	48	Serial clock output
CLK16	49	16MHz clock
CLK4_12	50	Configurable 4MHz or 12MHz clock
RESET	51	Power on reset (active low)
SDA	52	Micro interface data I/O line (open drain output)
SCL	53	Micro interface clock line
RAB	54	Micro interface R/W & load control line (4-wire)
SILD	55	Micro interface R/W & load control line (4-wire)
STATUS	56	Servo interrupt request line/decoder status register/DC offset value readback
RCK	57	Subcode clock
SUB	58	P to W subcode
SFSY	59	Subcode frame sync
SBSY	60	Subcode block sync
V _{SSD2}	61	Digital ground 2
DOBM	62	Bi-phase mark output (externally buffered)
V _{DD2}	63	Digital supply voltage 2
RA	64	Radial actuator
FO	65	Focus actuator
SL	66	Sledge actuator
MOTO1	67	Motor output 1
MOTO2	68	Motor output 2
V _{SSD3}	69	Digital ground 3
V _{DD3}	70	Digital supply voltage 3
V1	71	Versatile pin 1
V2	72	Versatile pin 2
V3	73	Versatile pin 3
V4	74	Versatile pin 4
V5	75	Versatile pin 5
TEST1	76	Test pin
TEST2	77	Test pin
TEST3	78	Test pin
TEST4	79	Test pin
LASER	80	Laser drive

**INTERNAL BLOCK DIAGRAM
CD AUDIO DECODER - IC SAA7824**

SAA7824

CD audio decoder, digital servo & filterless DAC
with integrated pre-amp & laser control

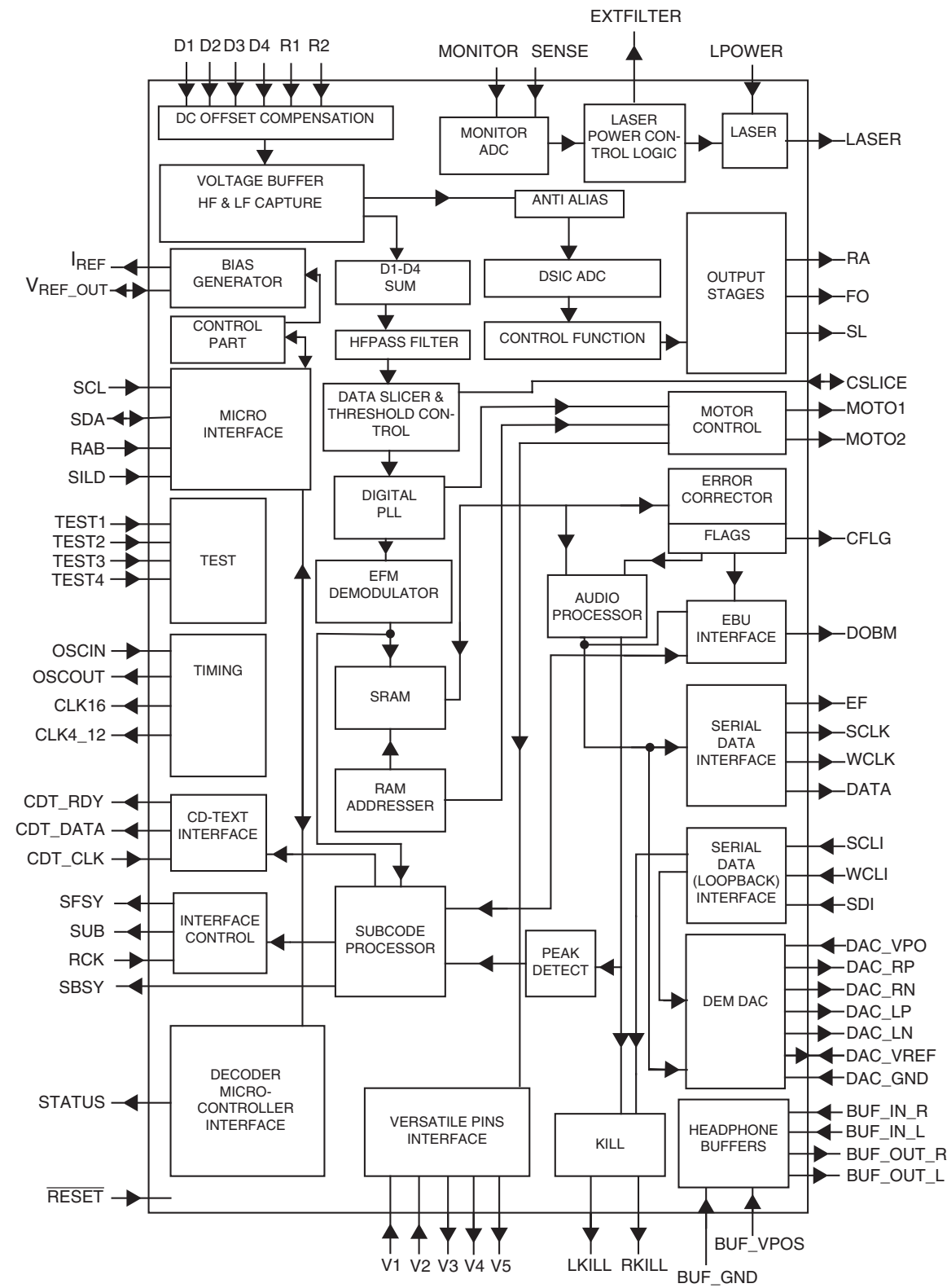

BLOCK DIAGRAM Universal Loader

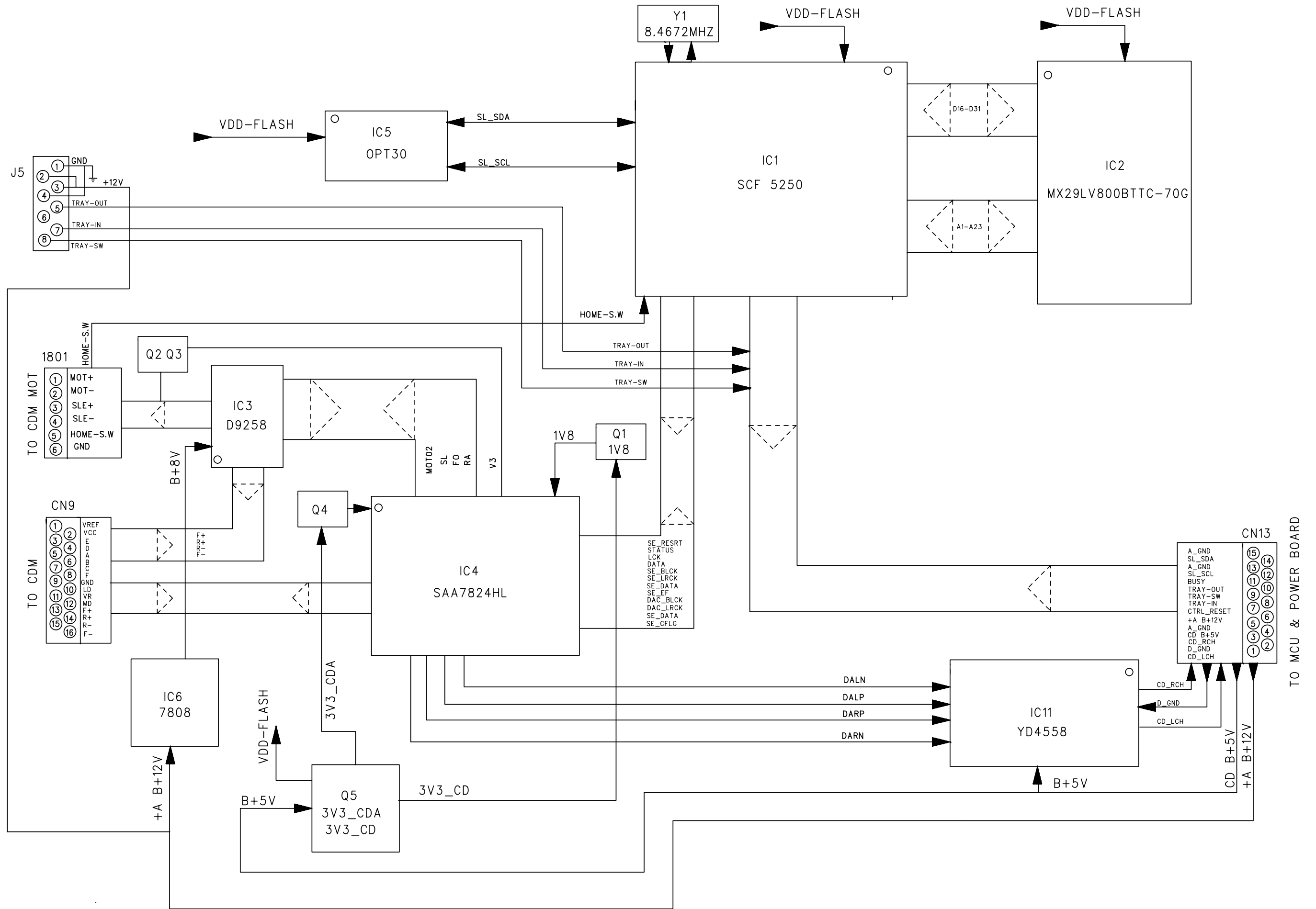

TRAY MOTOR BOARD / copper side view

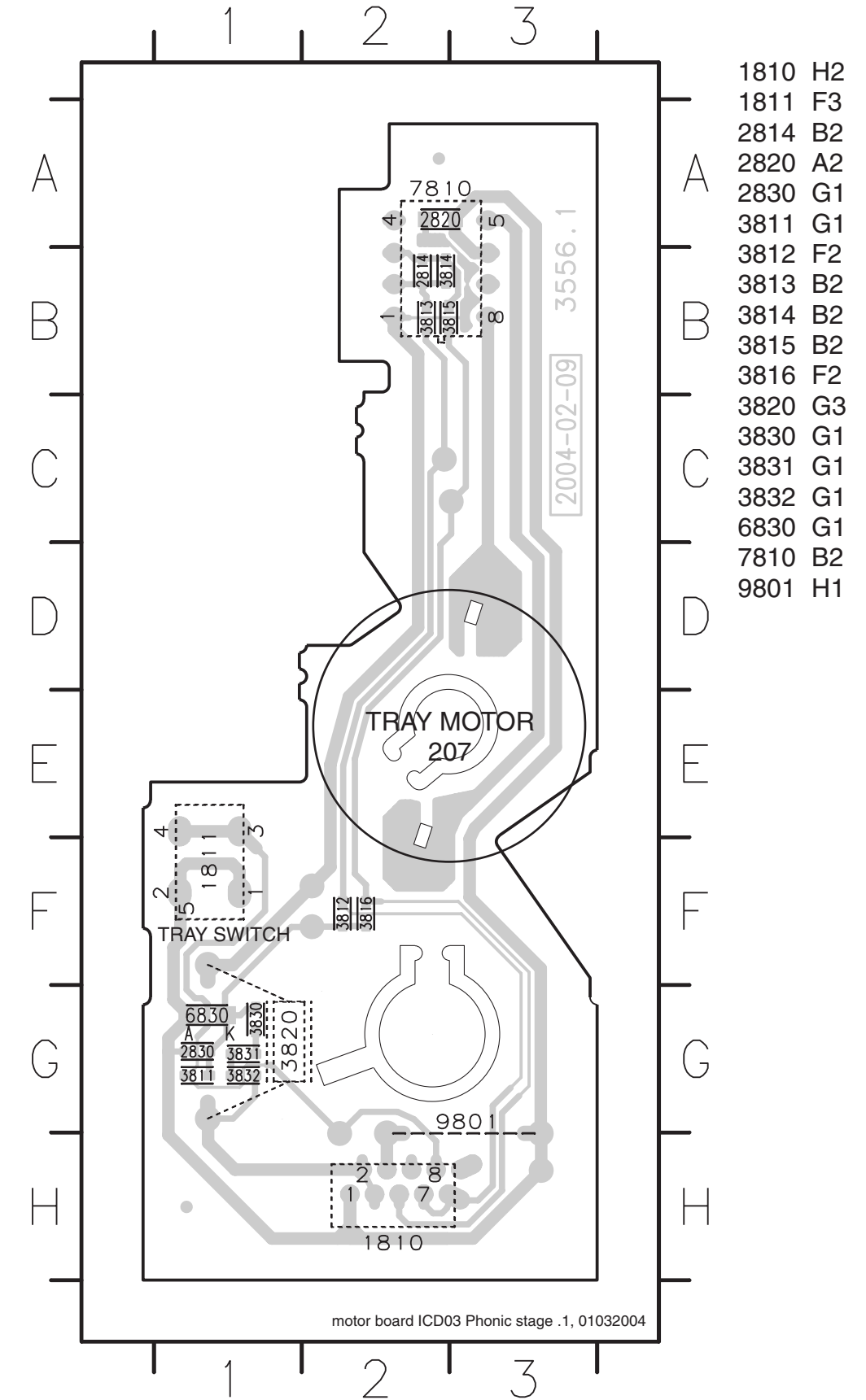

- 1810 H2
- 1811 F3
- 2814 B2
- 2820 A2
- 2830 G1
- 3811 G1
- 3812 F2
- 3813 B2
- 3814 B2
- 3815 B2
- 3816 F2
- 3820 G3
- 3830 G1
- 3831 G1
- 3832 G1
- 6830 G1
- 7810 B2
- 9801 H1

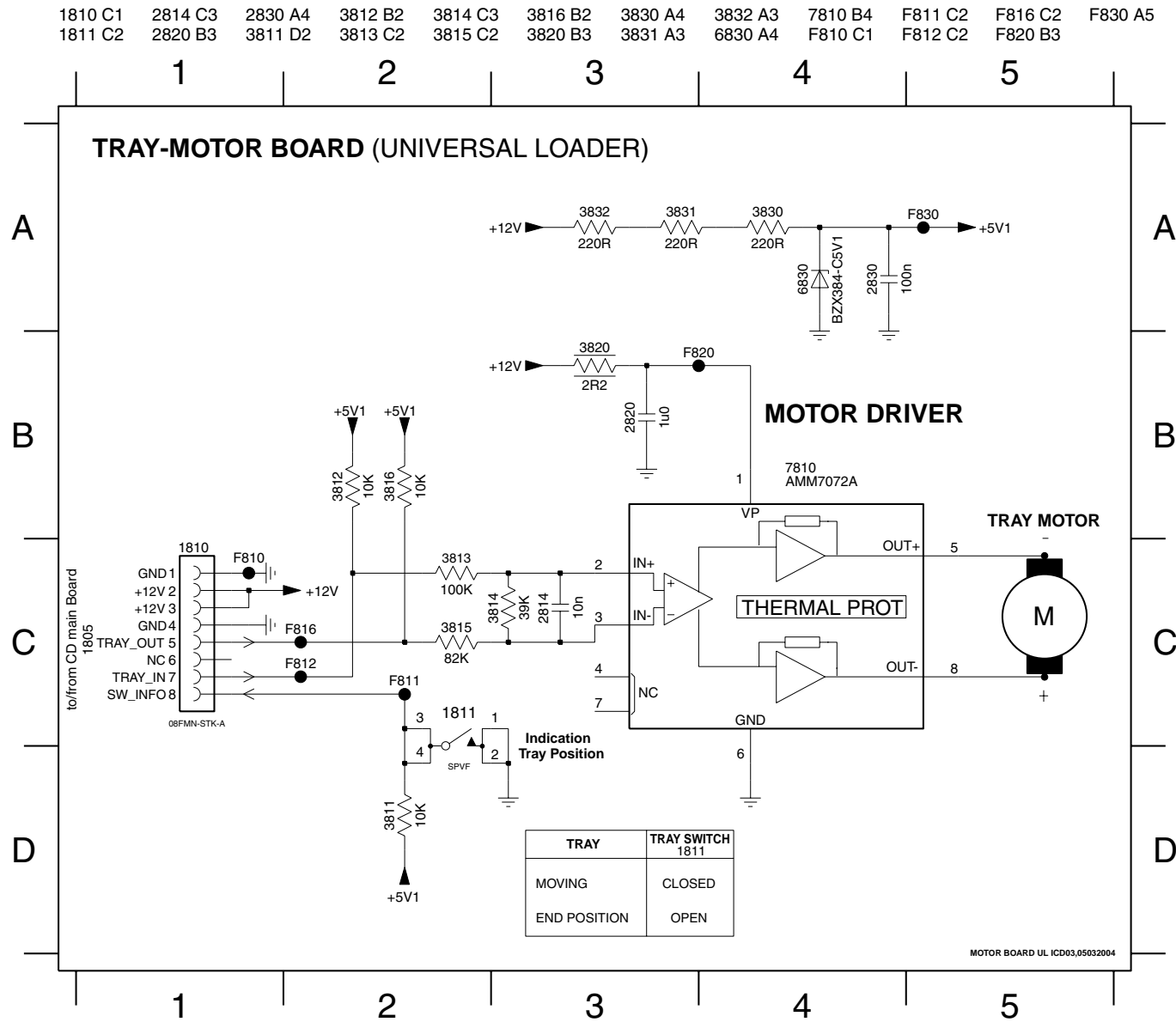

- 1810 C1
- 1811 C2
- 2814 C3
- 2820 B3
- 2830 A4
- 3811 D2
- 3812 B2
- 3813 C2
- 3814 C3
- 3815 C2
- 3816 B2
- 3820 B3
- 3830 A4
- 3831 A3
- 3832 A3
- 6830 A4
- 7810 B4
- F810 C1
- F811 C2
- F812 C2
- F816 C2
- F820 B3
- F830 A5

MOTOR BOARD UL ICD03.05032004

motor board ICD03 Phonic stage .1, 01032004

CIRCUIT DIAGRAM CD SECTION

FOR ORIENTATION ONLY

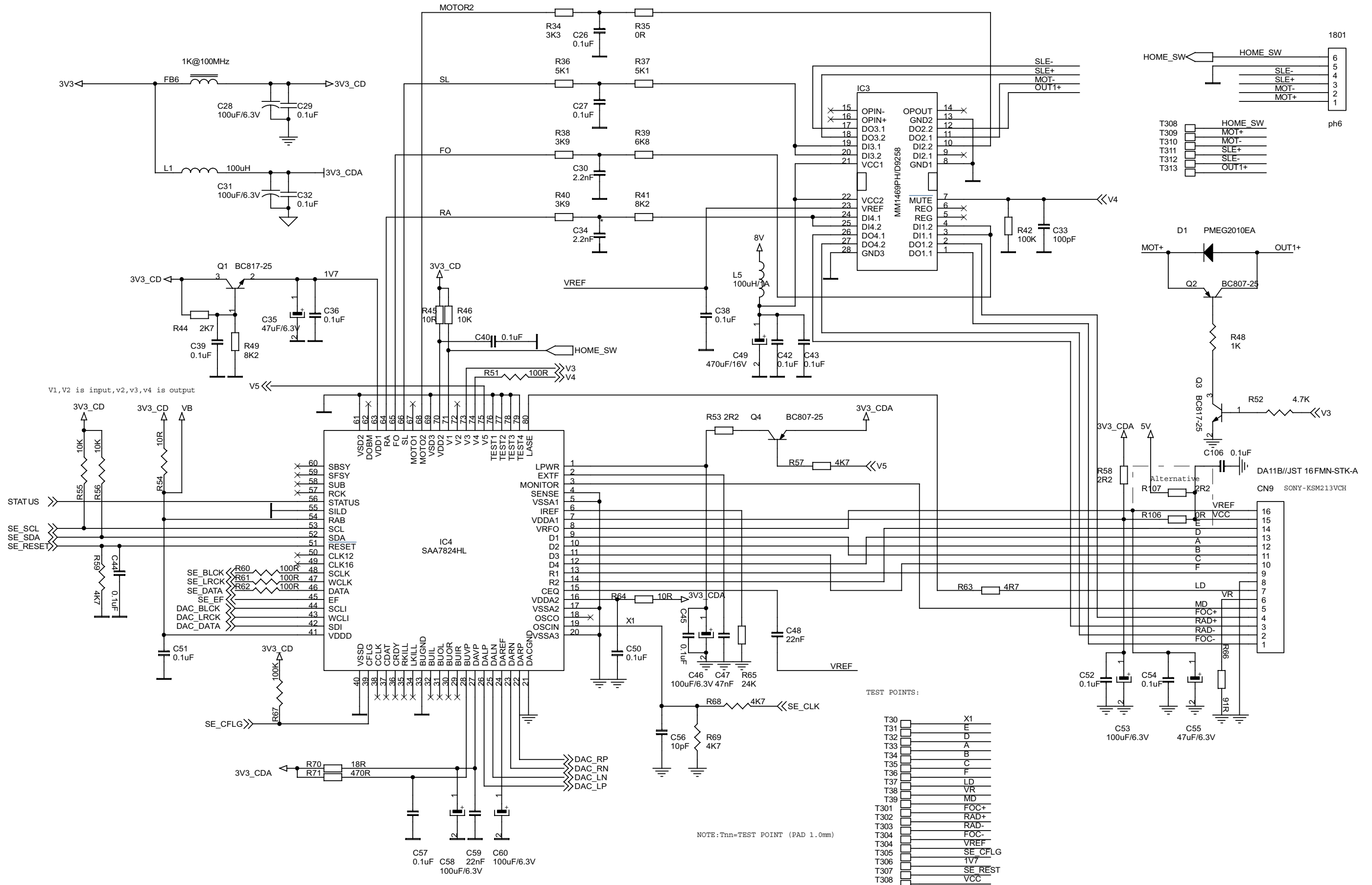

NOTE: Tnn=TEST POINT (PAD 1.0mm)

CIRCUIT DIAGRAM AUDIO SECTION

FOR ORIENTATION ONLY

Notes:
The C79 ,C91 must be placed as near to the CD18 as possible

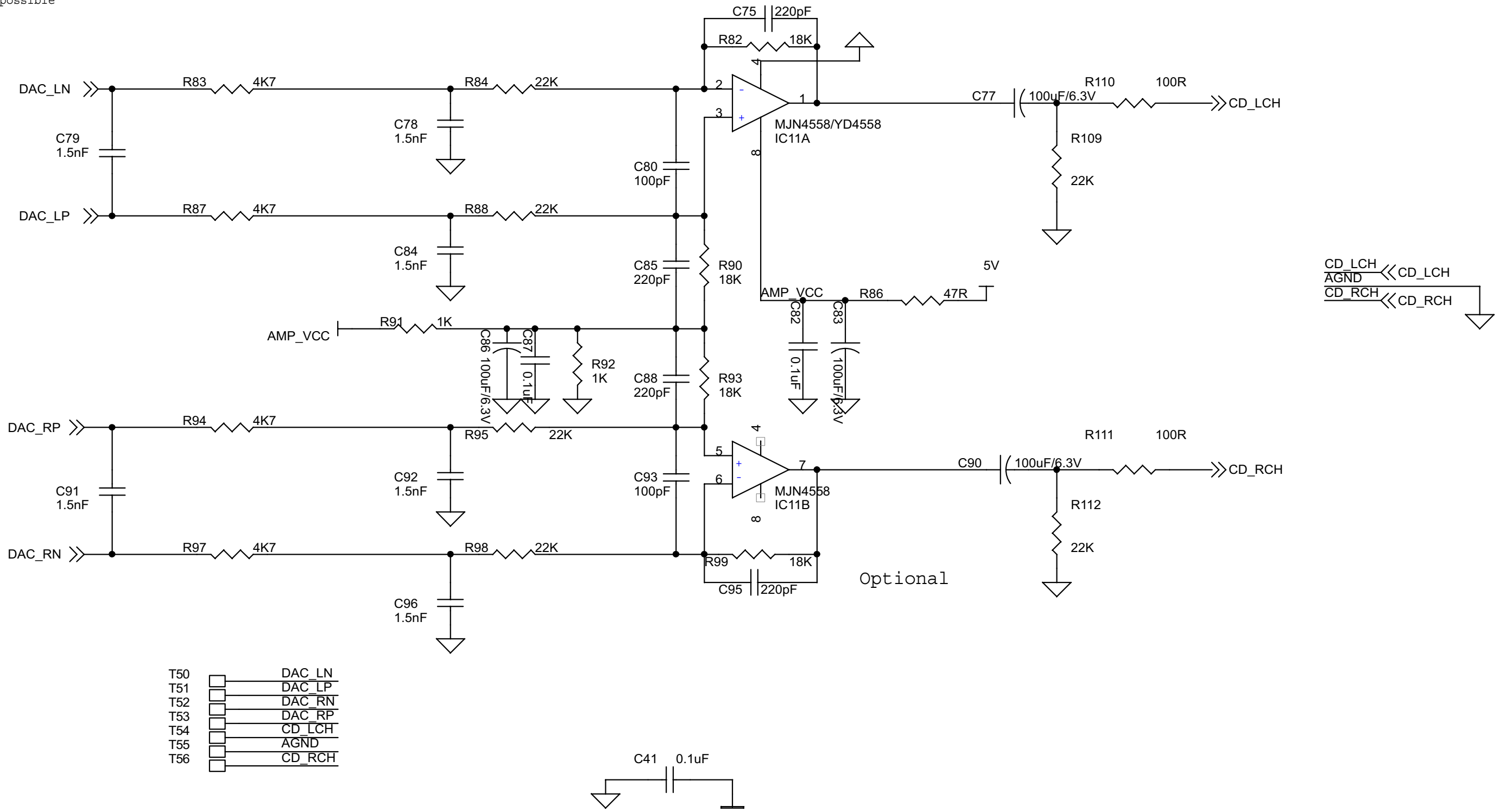

**CIRCUIT DIAGRAM
FLASH MEMORY SECTION**

FOR ORIENTATION ONLY

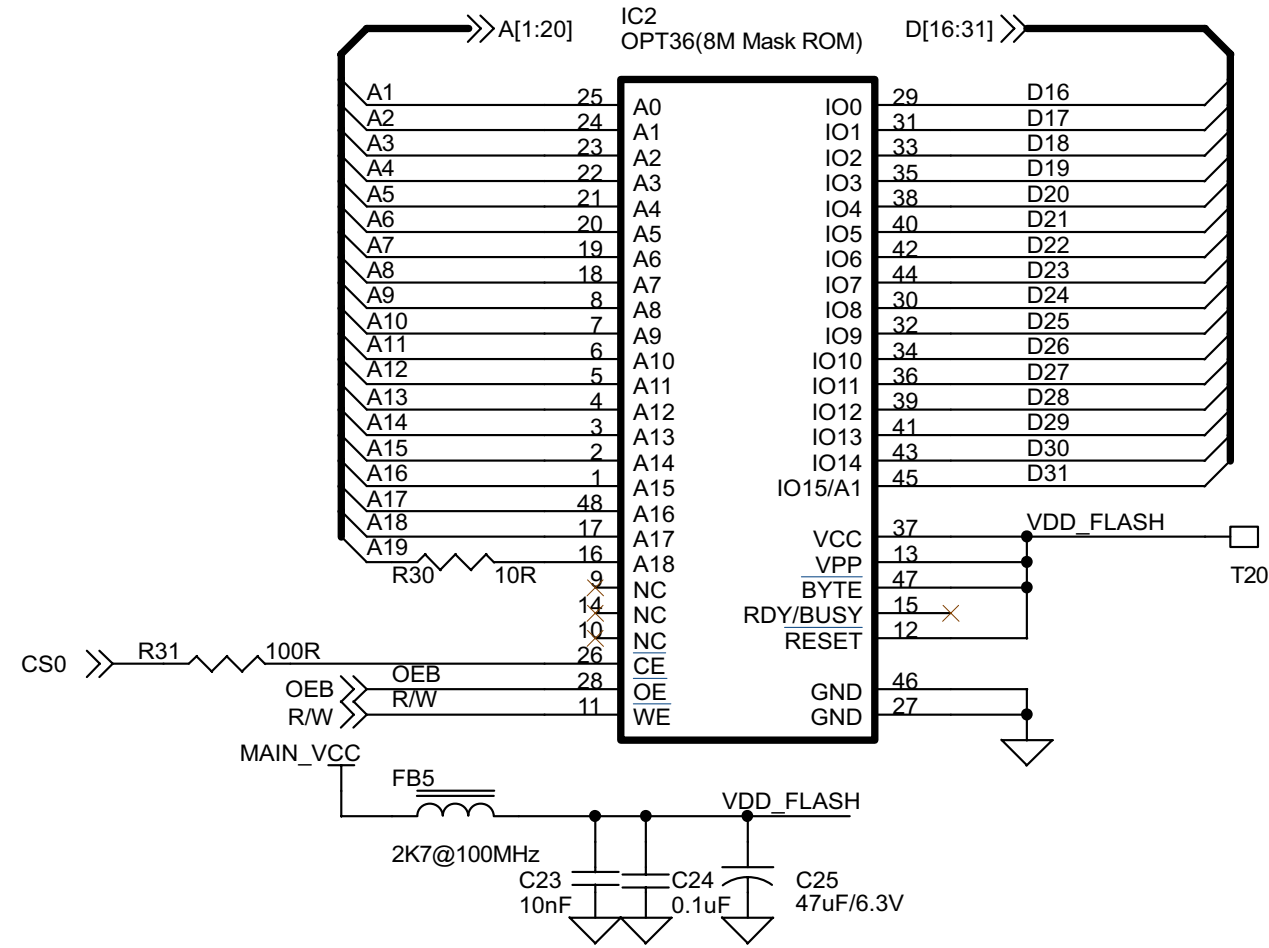

NOTE: Tnn=TEST POINT (PAD 1.0mm)

FOR ORIENTATION ONLY

For 1 DISC Only

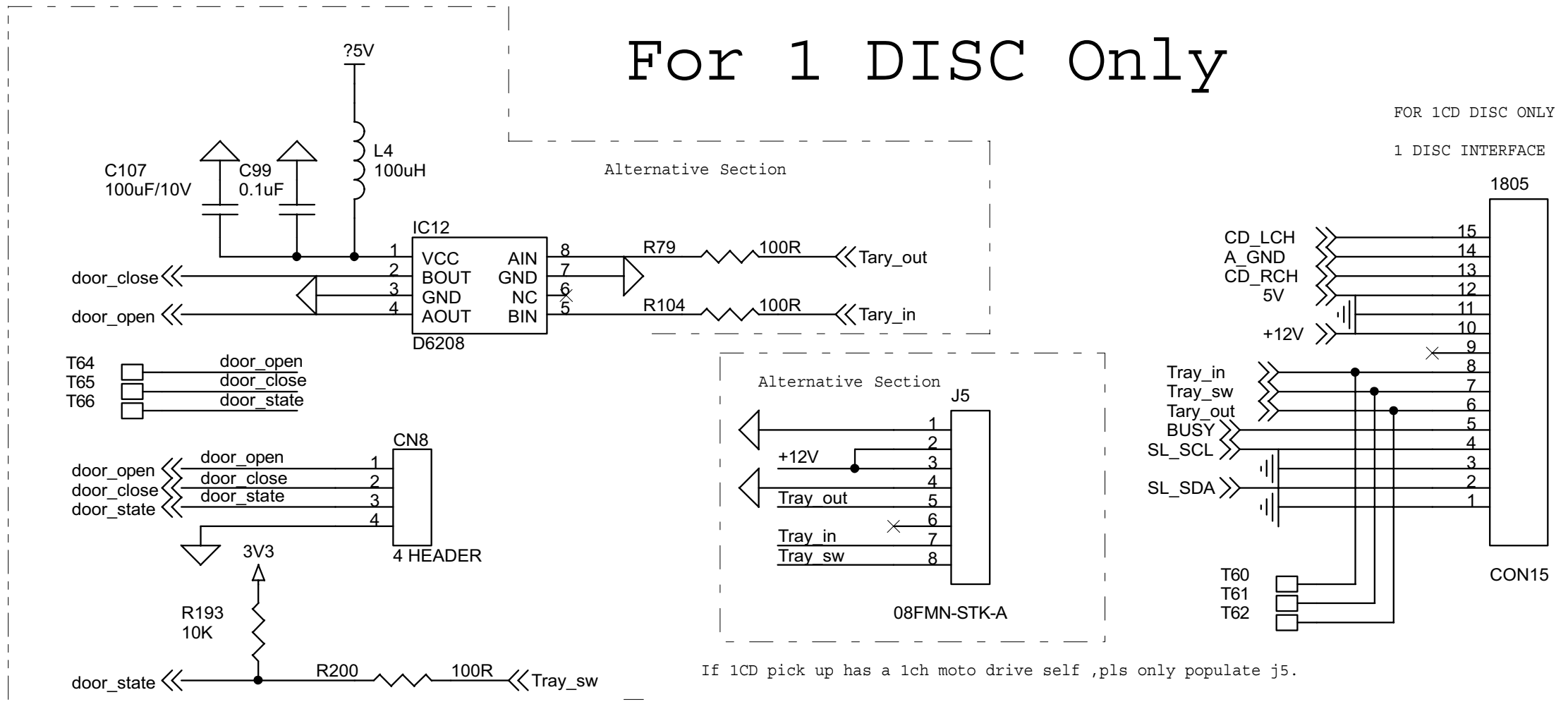

For 5 DISC Only

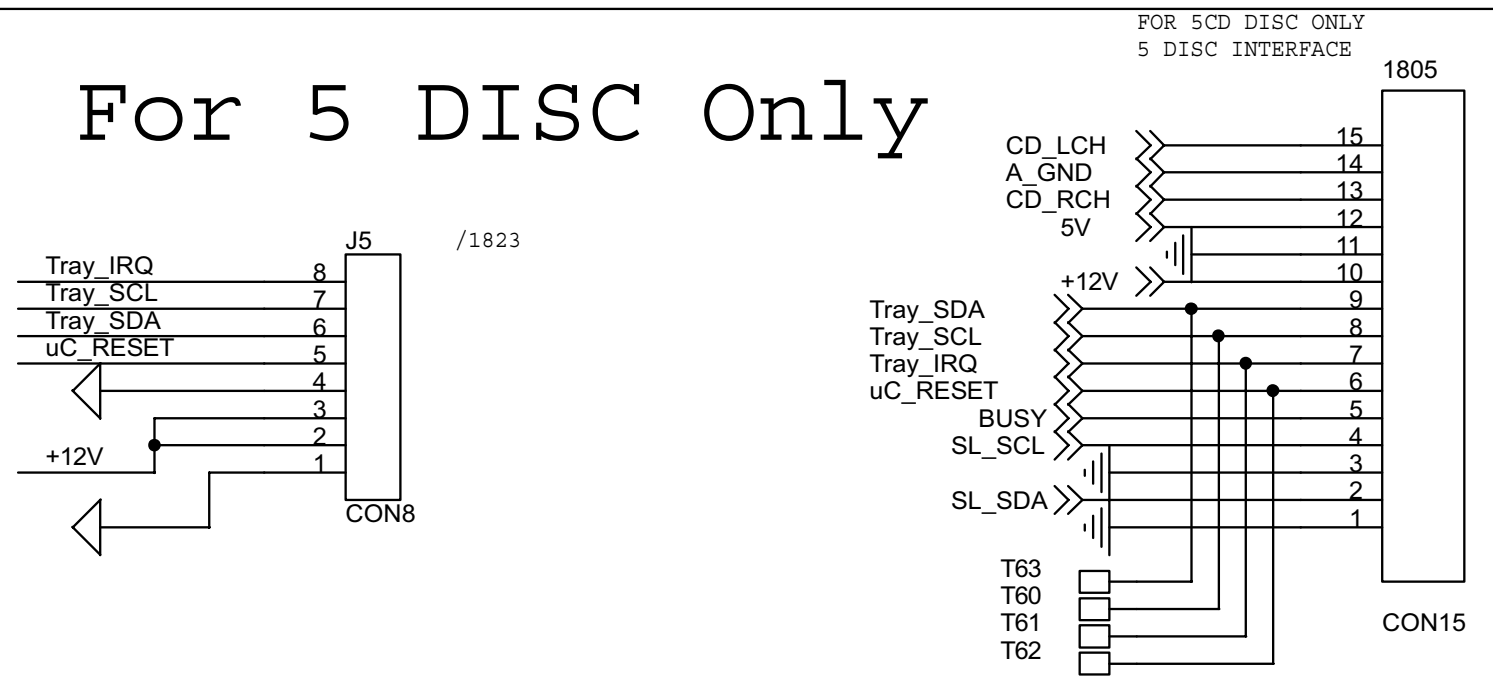

FOR ORIENTATION ONLY

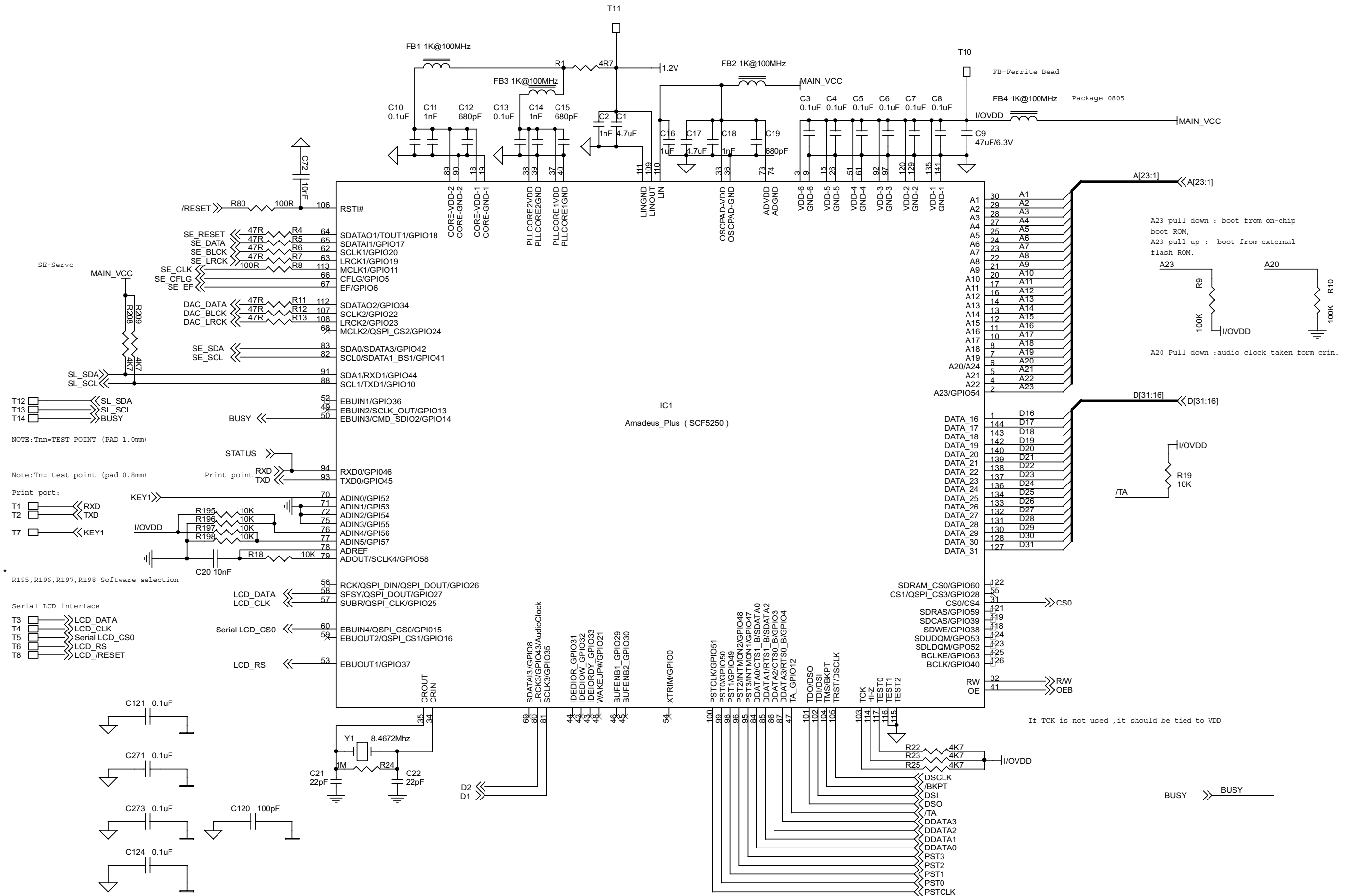

FOR ORIENTATION ONLY

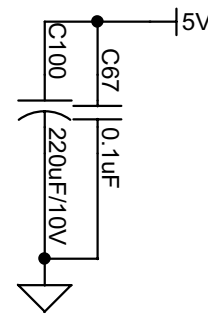
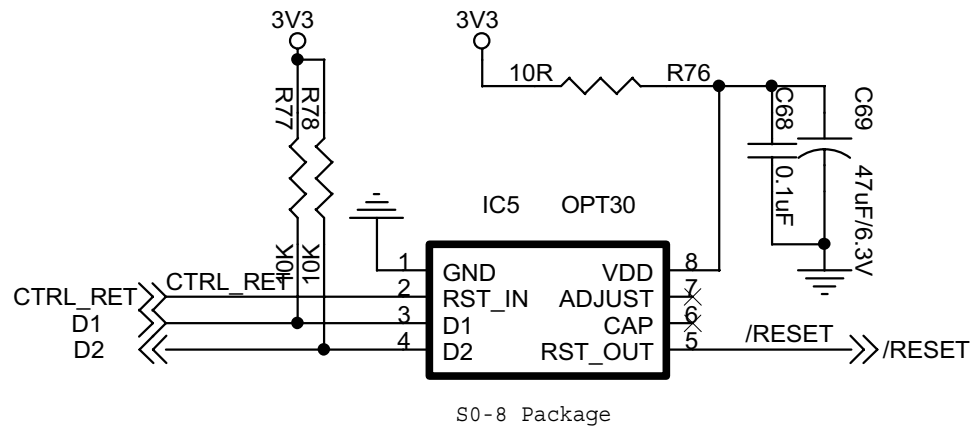
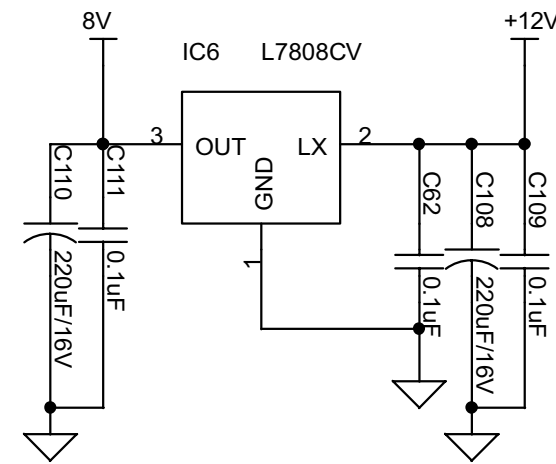
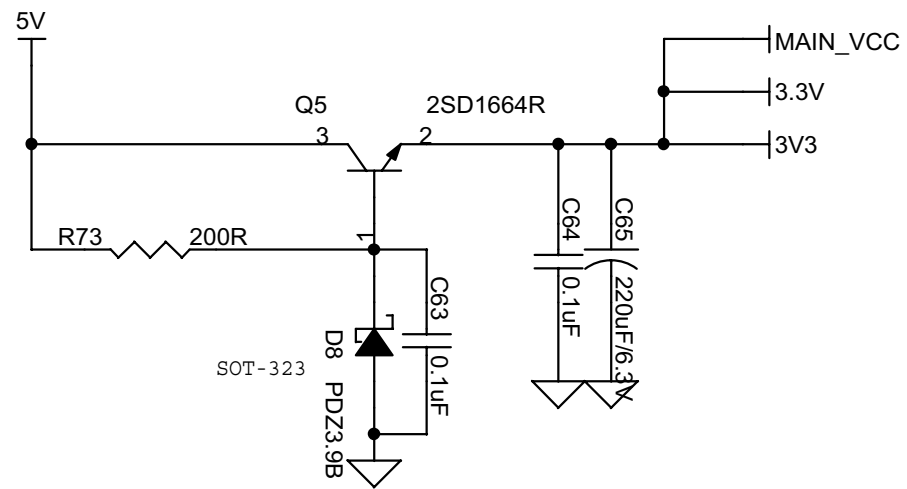
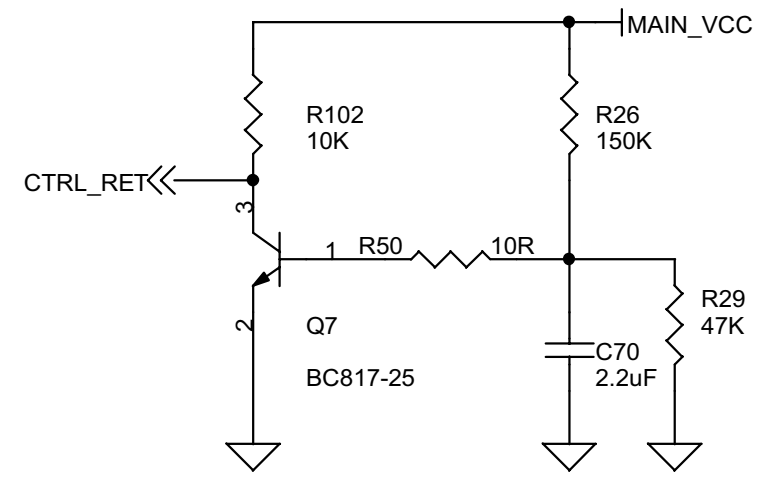
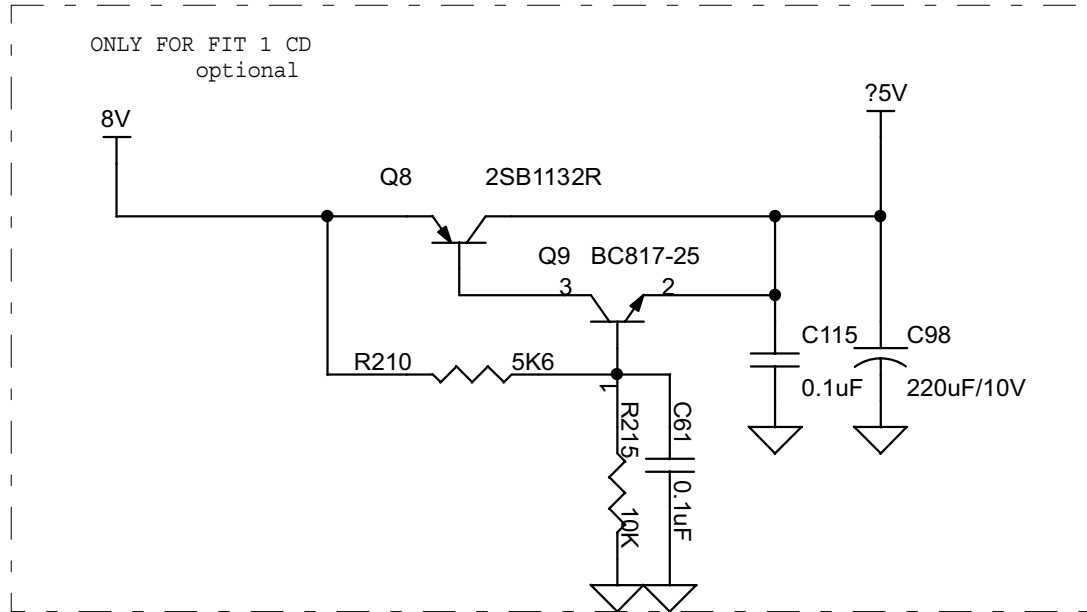

- T40 8V
- T41 5V
- T42 3V3
- T43 +12V
- T44 /RESET
- T45 CTRL_RET

LAYOUT DIAGRAM
TOP VIEW

FOR ORIENTATION ONLY

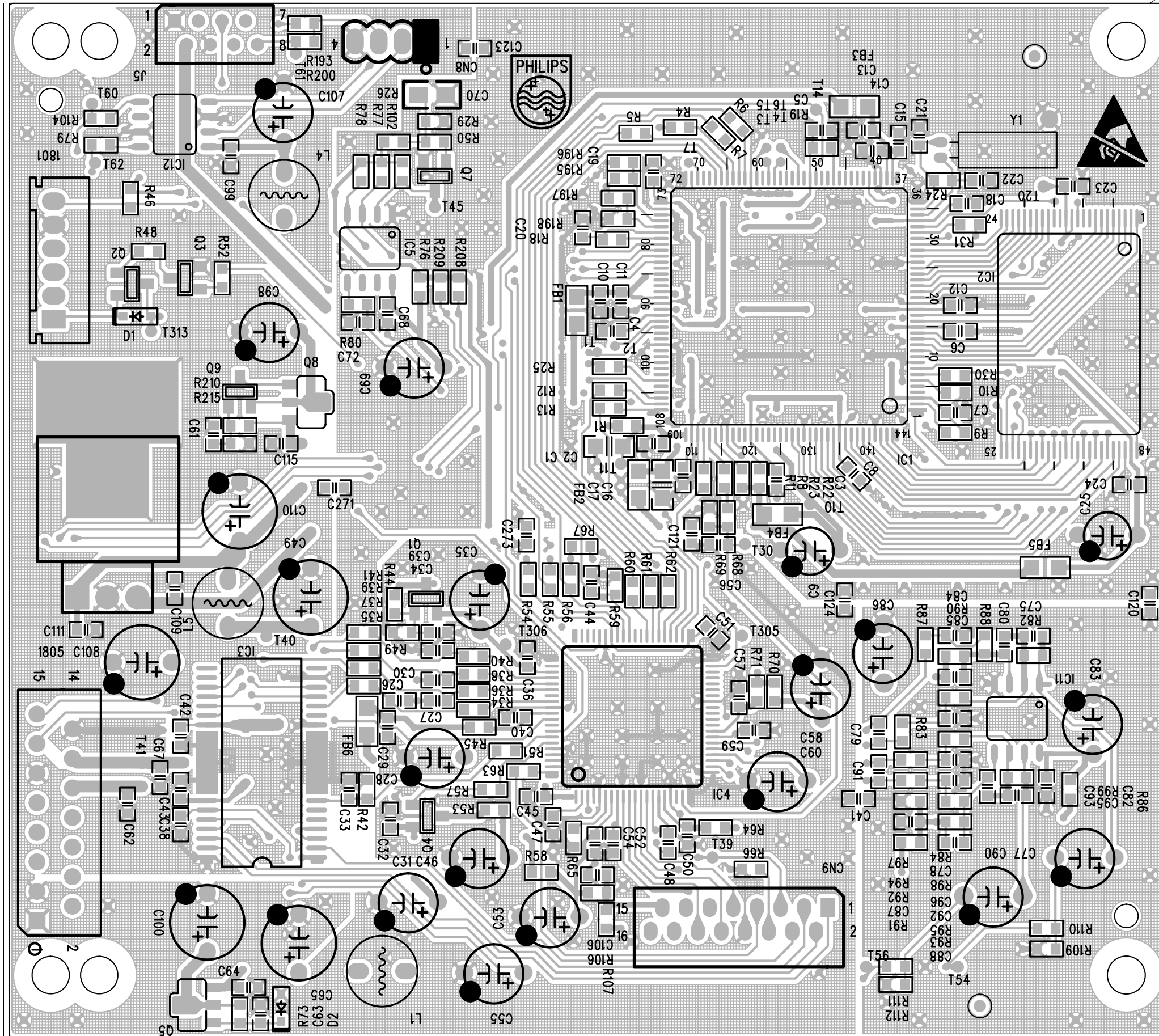

LAYOUT DIAGRAM
BOTTOM VIEW

FOR ORIENTATION ONLY

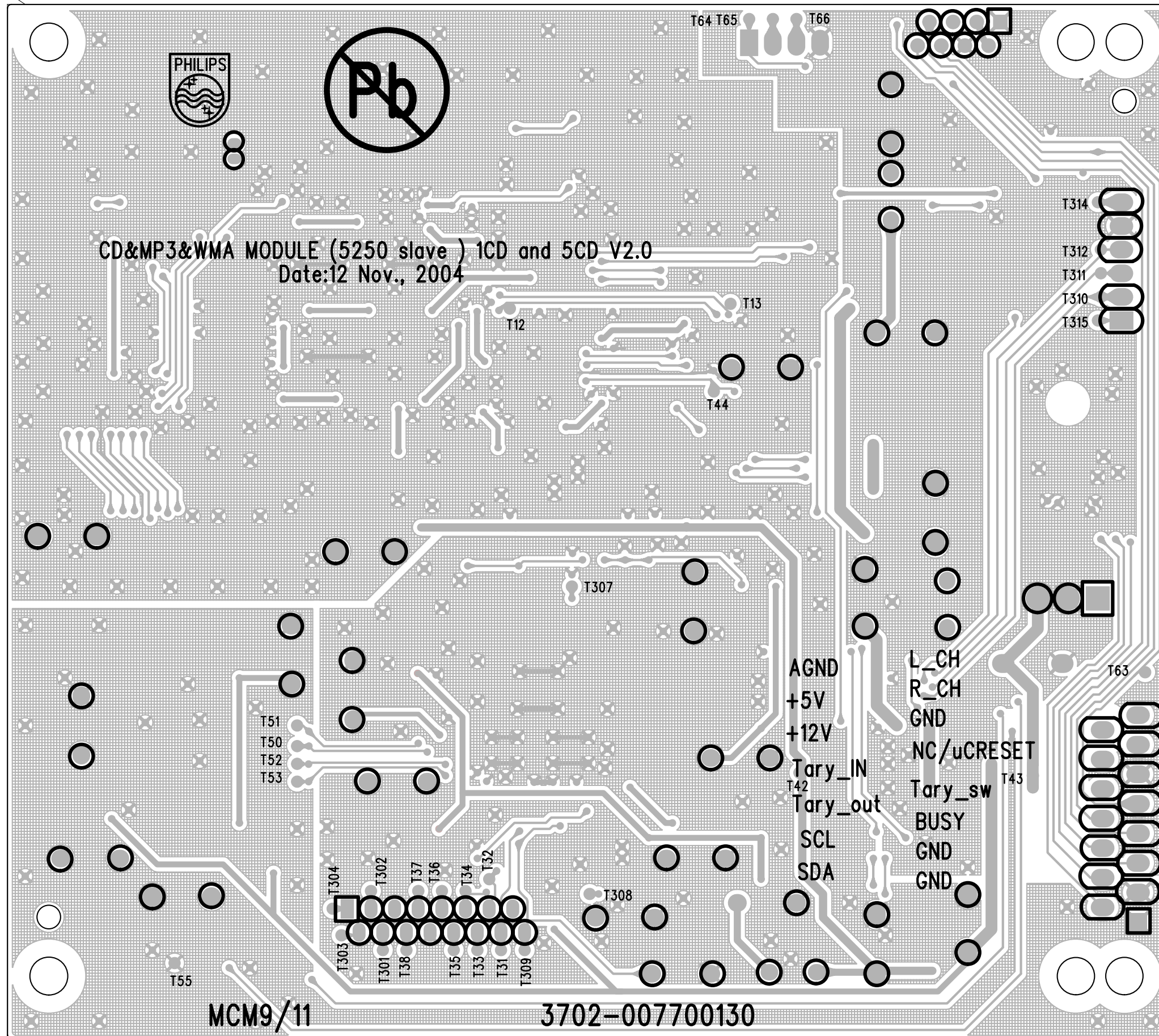

Exploded view **UNIVERSAL LOADER**

FOR ORIENTATION ONLY

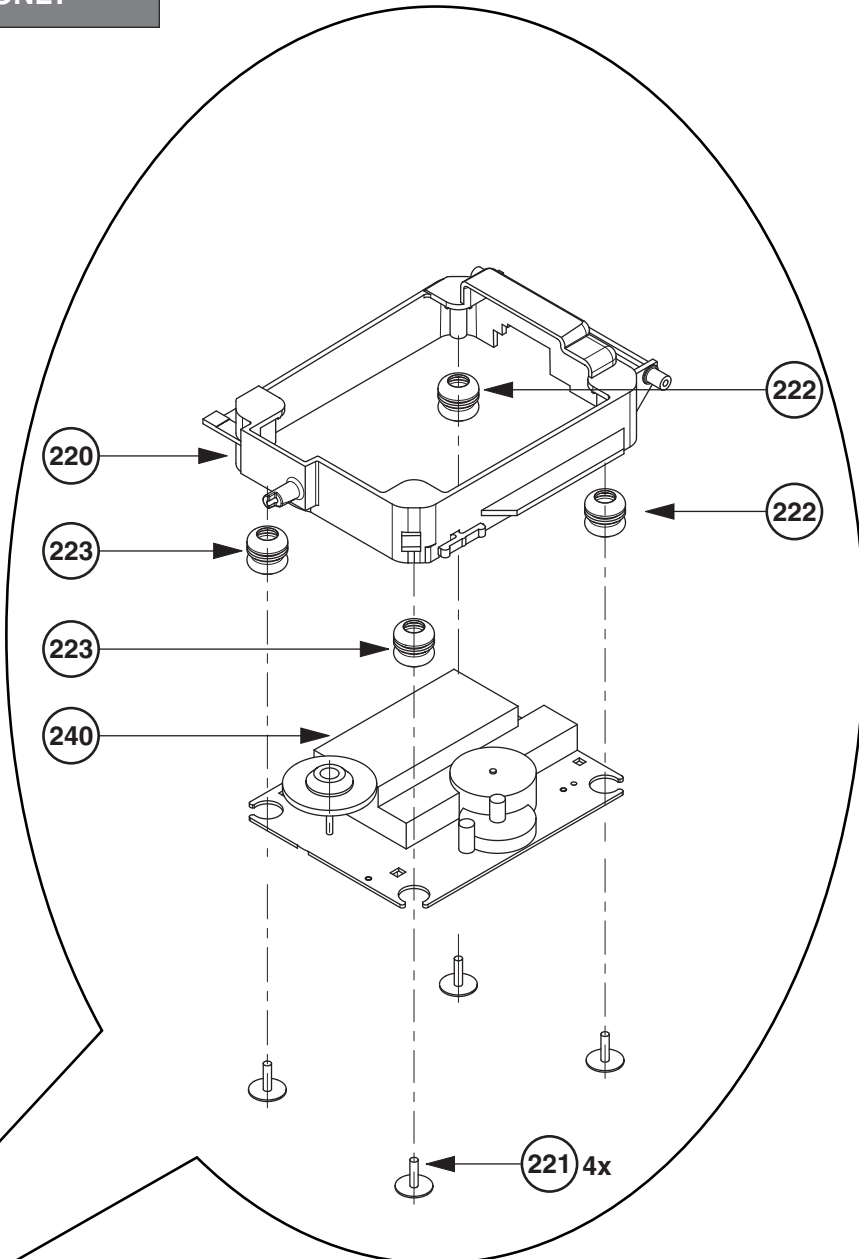
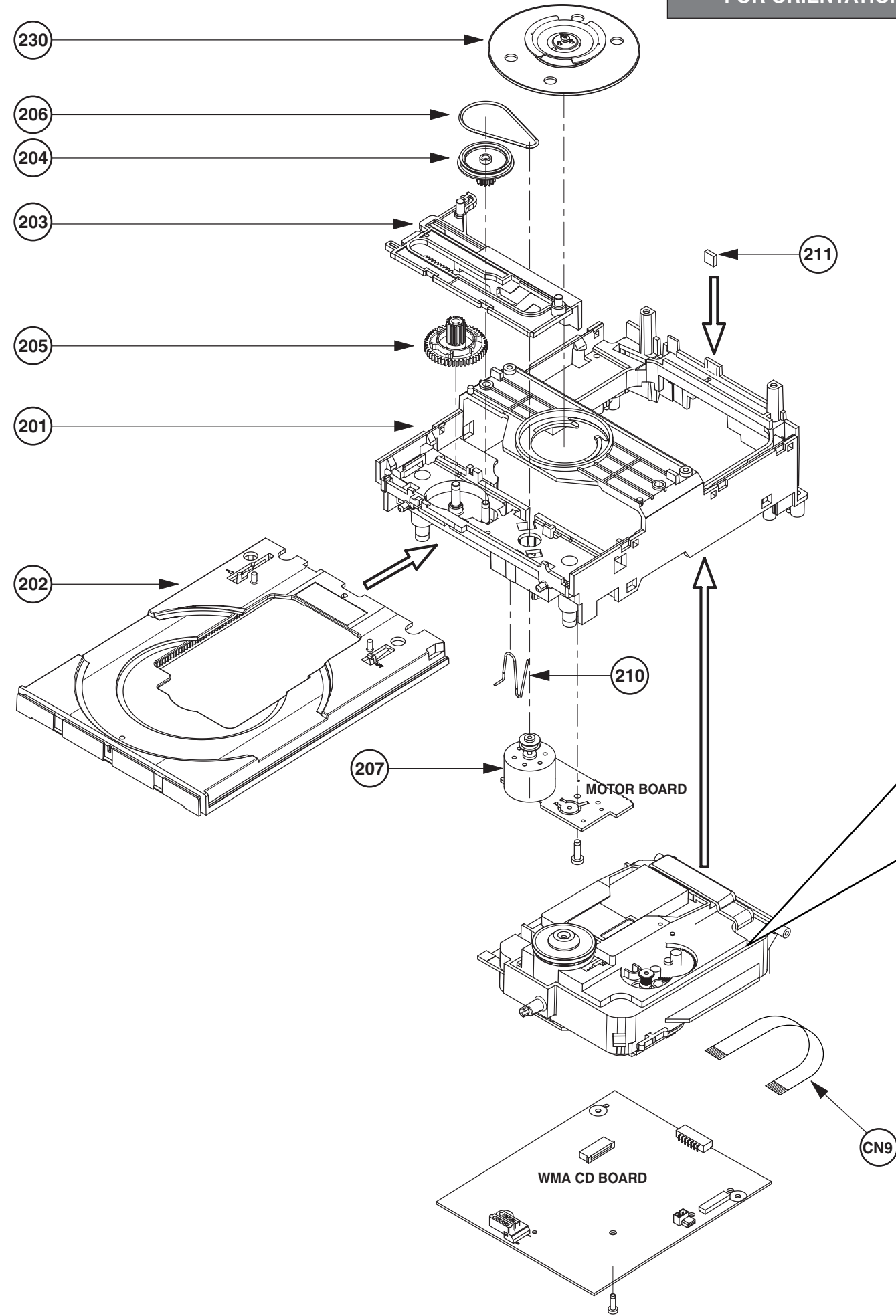

MECHANICAL PARTS

202	DRAWER SLIDER
203	SLIDER
204	PULLEY GEARWHEEL
205	GEARWHEEL
206	DRIVING BELT
207	MOTOR ASSY
210	SPRING SUPPORT
220	SUPPORT CD
222	RUBBER DAMPER CD DRIVE, FRONT
223	RUBBER DAMPER CD DRIVE, FRONT
230	CLAMPER ASSY DA11

SERVICE PARTS

240	9940 000 02055	CD DRIVER DA11VF
J5	3103 308 94021	FLEXFOIL CABLE, 8P, 268mm
CN9	9940 000 02122	FLEXFOIL CABLE, 16P, 170mm
	9940 000 02092	CD MECHANISM LOADER

ELECTRICAL PARTSLIST Universal Loader

MOTOR BOARD

Only complete board available

9940 000 02111 MOTOR BOARD ASS'Y

WMA-MP3-CD BOARD

Only complete board available

9940 000 02078 WMA CD BOARD ASS'Y

COMBI & REGULATOR BOARDS

TABLE OF CONTENTS

Regulator Board

Brief Introduction of the Regulator Board.....	11-1
Component & Copper Side View	11-2
Circuit diagram.....	11-3

Combi Board

Component View seen from Copper Side	11-4
Copper Side View	11-5
Circuit diagram - Source Selector part	11-6
Circuit diagram - Amplifier part	11-7
Electrical parts list.....	11-8

Brief introduction of the Regulator Board

The regulator board provides the following:

- a) 12V supply: +12V_A and +12V_M derived from the +A supply
- b) 5,6V and 5V supply: +5V6 and 5V_VCD derived from the +A/2 supply

Technical Remarks

REGULATOR BOARD - COMPONENT SIDE VIEW

1171 A2	2408 A1	3404 A2	3417 A3	3430 A2	6401 A2	7405 A3	7419 A4	9411 A4
1400 B3	2409 A2	3405 A1	3418 A1	3431 B2	6402 A3	7406 A3	7420 A4	9412 A2
1401 A4	2410 A2	3406 A2	3419 B3	3432 B2	6404 A3	7407 A3	7421 A4	9413 B3
1402 B4	2411 B4	3407 A3	3420 B2	3433 B4	6405 A3	7408 A3	9172 A2	9414 A3
1403 A4	2412 B1	3409 A2	3421 B3	3434 B4	6406 B3	7409 B3	9174 A2	9415 A4
2400 A1	2413 A2	3410 A3	3422 A1	3435 B3	6407 B2	7410 A3	9401 A4	9416 B4
2402 A4	2415 A4	3411 B2	3423 A2	3436 A4	6409 A2	7411 A3	9402 A4	9417 A4
2403 A3	2416 B4	3412 A4	3424 A1	3437 A4	6412 B4	7412 B4	9403 A4	9419 A4
2404 A2	2417 B3	3413 A4	3425 A1	3438 A4	6413 B4	7413 A1	9404 A1	9420 A3
2405 A3	2418 A2	3414 A4	3426 B1	3439 A4	7401 A2	7414 B1	9405 A1	
2406 B2	2420 B3	3415 A3	3427 B2	3440 A4	7402 A2	7415 B1	9406 A4	
2407 B2	3403 A1	3416 A3	3428 B2	6400 A2	7403 A1	7417 A1	9410 A2	

REGULATOR BOARD - COPPER SIDE VIEW

1171 A2	2409 B3	3405 A4	3418 A4	3431 B3	6402 A3	7406 A2	7420 A1	9412 A3
1400 B2	2410 A3	3406 A3	3419 B2	3432 B3	6404 A3	7407 A2	7421 A1	9413 B2
1401 A1	2411 A1	3407 A2	3420 B3	3433 B1	6405 A2	7408 A2	9172 A3	9414 A2
1402 A1	2412 B3	3409 A3	3421 B2	3434 B1	6406 B2	7409 B2	9174 A3	9415 A1
2400 A4	2413 A3	3410 A2	3422 A4	3435 B2	6407 B3	7410 A3	9401 A1	9416 B1
2402 A1	2415 B1	3411 B3	3423 A3	3436 A1	6409 A3	7411 B2	9402 A1	9417 A1
2403 A2	2416 B1	3412 A2	3424 A4	3437 A1	6412 B1	7412 B1	9403 A1	9419 A1
2404 A3	2417 B2	3413 A1	3425 A4	3438 A1	6413 B1	7413 A4	9404 A4	9420 A2
2405 A2	2418 A3	3414 A1	3426 B3	3439 A1	7401 A3	7414 B4	9405 A4	
2406 B3	2420 B2	3415 A2	3427 B3	3440 A1	7402 A3	7415 B4	9406 A1	
2407 B2	3403 A4	3416 A2	3428 B3	6400 A3	7403 A4	7417 A4	9410 A3	
2408 A4	3404 A3	3417 A2	3430 A3	6401 A3	7405 A1	7419 A1	9411 A1	

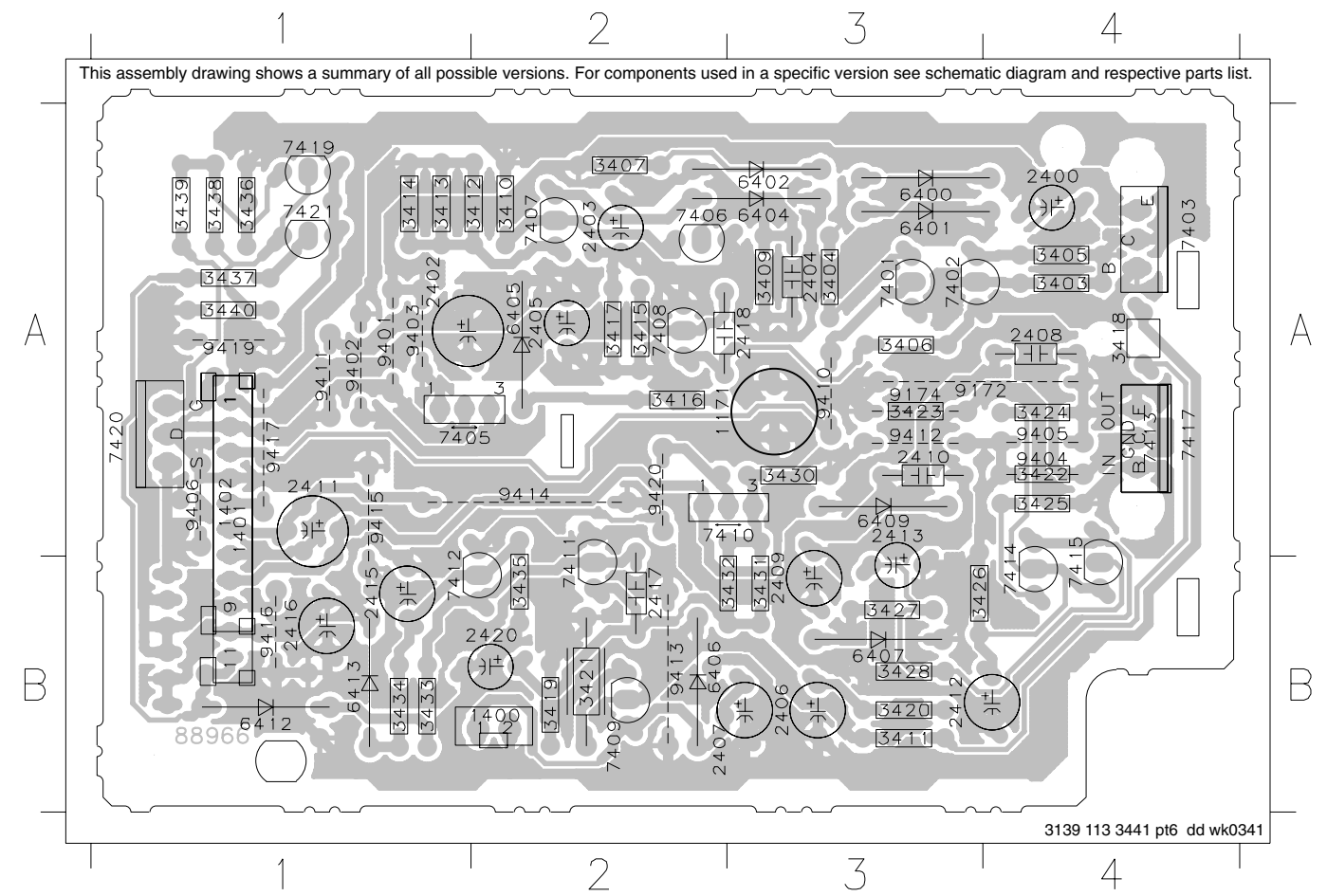
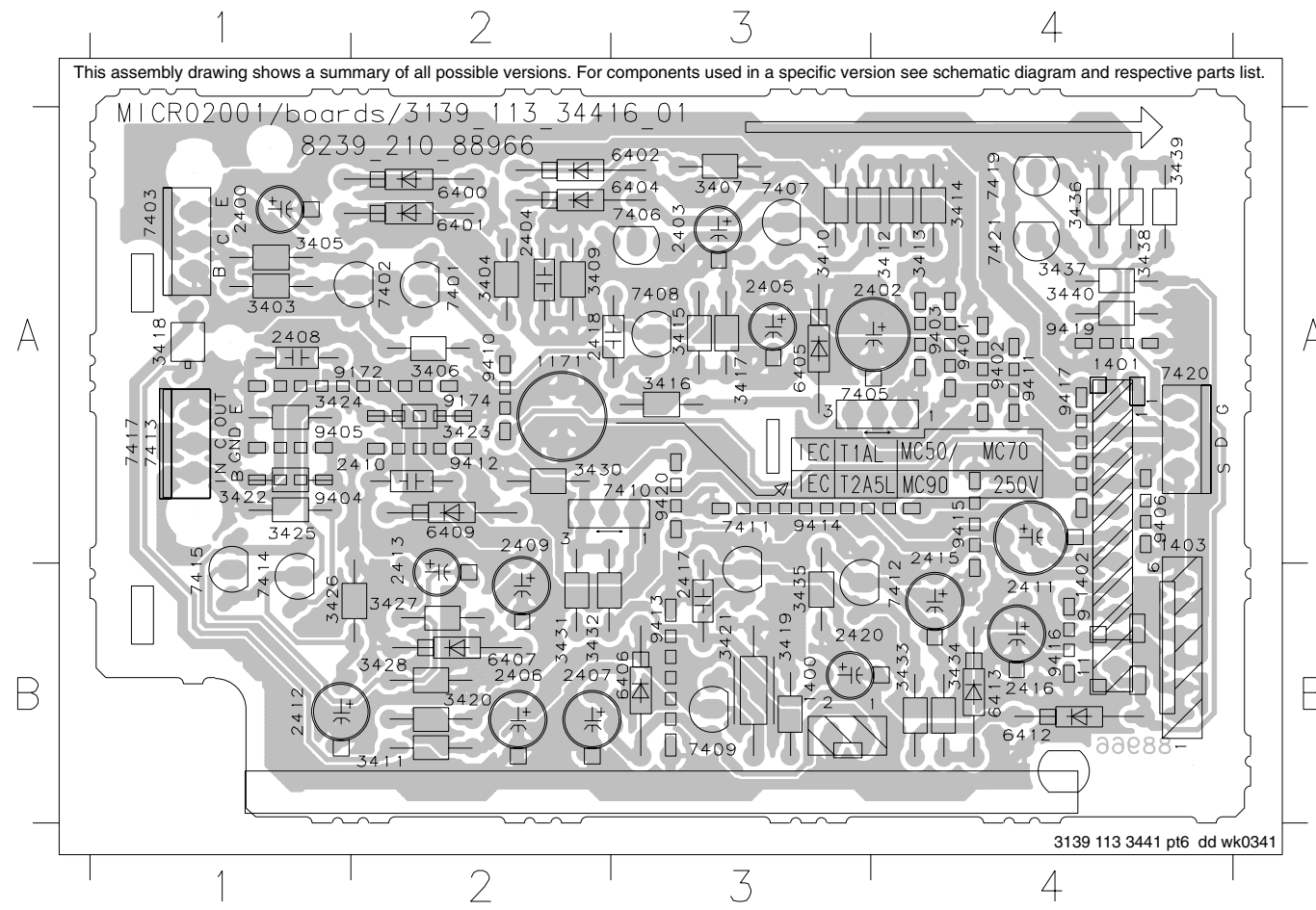

REGULATOR BOARD - CIRCUIT DIAGRAM

1171 C2	1403 E1	2404 C5	2408 D5	2412 F3	2417 D6	3404 B4	3409 C5	3413 B6	3417 C7	3421 A8	3425 E3	3430 D6	3434 E7	3438 F1	6401 C4	6406 B8	6413 D7	7405 A6	7409 B9	7413 D3	7419 F1	9174 D2	9406 E1
1400 B9	2400 B5	2405 B7	2409 E4	2413 E3	2418 B7	3405 A4	3410 B6	3414 B6	3418 B8	3422 D3	3426 E3	3431 D6	3435 E7	3439 F1	6402 B5	6407 E4	7401 B4	7406 C6	7410 D7	7414 F3	7420 E1	9401 A6	
1401 A1	2402 A7	2406 B8	2410 E5	2415 E7	2420 E6	3406 B5	3411 B8	3415 C7	3419 A8	3423 D2	3427 E4	3432 D6	3436 E2	3440 F1	6404 C6	6409 E5	7402 B4	7407 B6	7411 E6	7415 F3	7421 F2	9404 D3	
1402 A1	2403 C5	2407 B8	2411 C3	2416 D7	3403 A4	3407 B5	3412 B6	3416 B7	3420 B8	3424 E2	3428 F4	3433 D7	3437 F2	6400 B4	6405 B7	6412 D7	7403 A4	7408 B7	7412 E7	7417 D5	9172 D2	9405 D4	

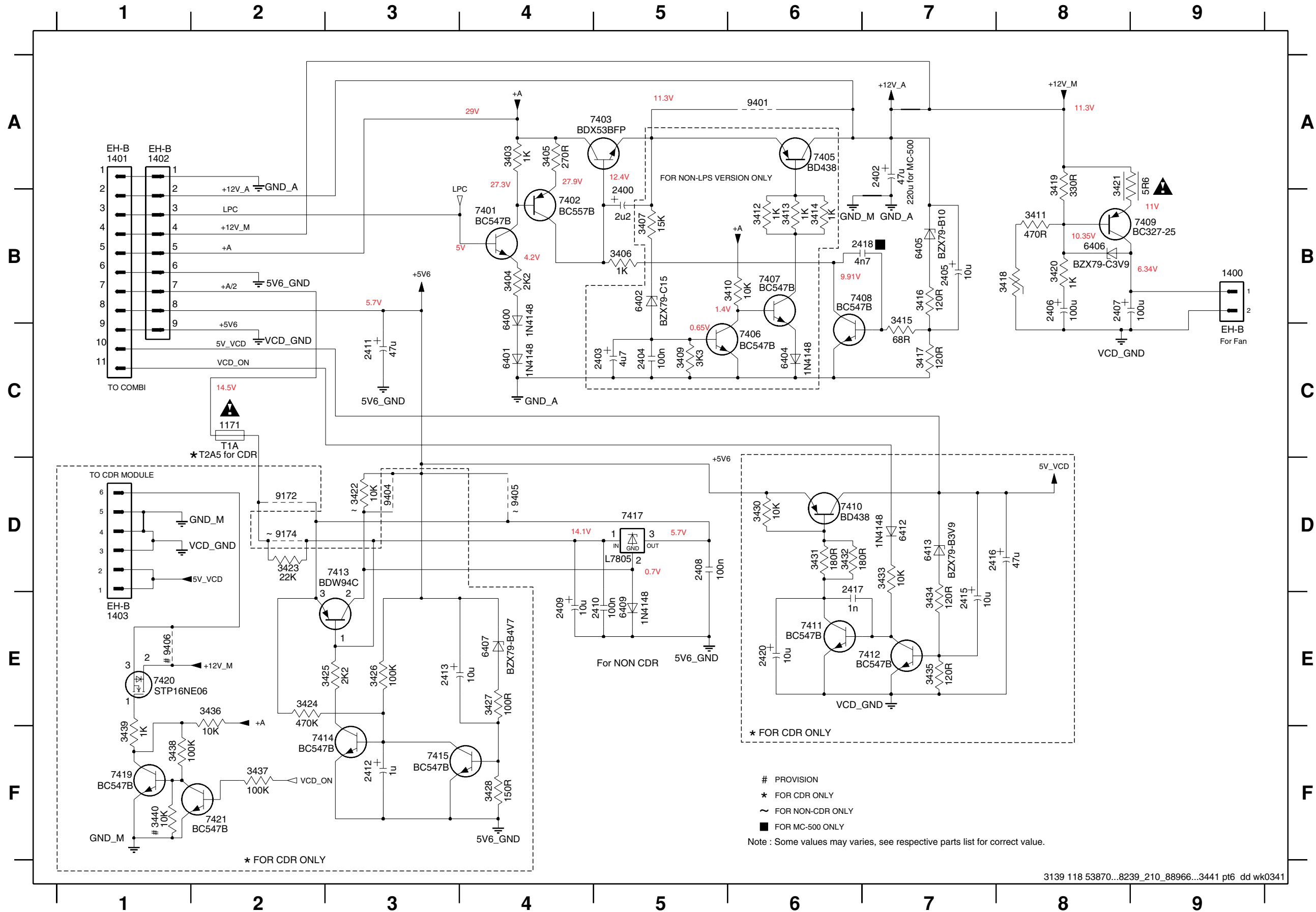

COMBI BOARD

0300 D6	1022 D1	1315 E3	2030 F3	2080 B5	2314 C7	2336 C6	2547 D4	3067 D1	3713 E2	6003 A6	6311 D6	6332 F6	9206 B7	9216 B5	9226 A7	9238 B2	9249 A2	9260 C5	9271 E7	9281 E4	9294 E3	9304 E1
1001 B9	1023 E1	1316 B5	2032 C1	2081 B5	2317 E9	2341 D4	2550 C2	3300 E4	5001 A9	6005 C2	6315 F7	7301 E8	9207 A8	9217 A4	9228 A2	9239 B2	9250 B6	9261 D6	9272 E6	9284 D3	9295 D3	9305 F2
1002 A7	1025 A3	2011 B4	2033 F1	2300 F6	2318 D9	2511 C2	2551 B3	3309 D8	5300 D8	6300 F9	6323 F7	7302 C8	9208 A7	9218 B4	9229 A2	9240 B2	9251 C6	9262 D6	9273 E5	9285 D3	9296 D3	9306 F3
1004 C9	1026 A2	2014 B8	2046 F1	2305 E7	2319 E9	2512 C4	2560 D3	3310 C9	5301 E8	6301 E8	6324 F6	7304 D8	9209 B6	9219 B4	9230 A2	9241 C2	9252 C6	9264 D6	9274 E5	9286 D3	9297 D3	9307 F2
1006 A3	1300 C7	2015 B4	2047 C2	2306 C7	2320 D9	2513 C3	2561 D3	3311 E8	5302 C8	6302 F9	6325 D8	7308 F8	9210 B6	9220 B4	9232 A2	9243 C2	9254 C7	9265 D7	9275 E4	9287 E3	9298 E2	9308 E2
1013 A4	1301 D7	2017 B3	2048 D2	2309 D7	2321 E9	2514 C4	2701 E2	3312 D9	5303 E8	6303 E8	6326 F3	7301 B8	9211 B6	9221 B4	9233 B2	9244 C3	9255 C7	9266 D7	9276 E5	9288 E3	9299 D2	9311 E2
1014 F1	1302 D5	2020 B8	2055 B8	2310 C7	2322 D9	2515 C2	2708 E2	3315 E6	5700 F2	6304 D6	6327 F3	7302 B8	9212 B6	9222 B3	9234 B1	9245 C4	9256 C7	9267 E7	9277 E5	9289 E3	9300 D2	9312 B7
1015 D1	1304 F2	2021 C1	2056 E2	2311 D8	2323 E5	2516 C4	2714 F2	3340 F8	6000 F3	6306 F6	6328 F5	7303 A7	9213 B6	9223 A3	9235 C1	9246 C4	9257 C6	9268 E7	9278 E4	9290 E3	9301 E2	
1018 A6	1307 F9	2023 B4	2058 C1	2312 C8	2334 C6	2517 D3	2716 E1	3353 E6	6001 F3	6307 F7	6330 F4	7304 E2	9214 A6	9224 E3	9236 E5	9247 C5	9258 D7	9269 E7	9279 E4	9291 E3	9302 E1	
1020 B6	1314 C6	2027 B5	2069 A8	2313 E7	2335 D7	2518 D4	3046 A6	3366 F5	6002 B2	6308 C6	6331 D5	7305 B7	9215 A7	9225 A3	9237 C2	9248 A2	9259 D6	9270 E7	9280 F3	9293 F3	9303 D1	

Hole mounted components seen from copperside

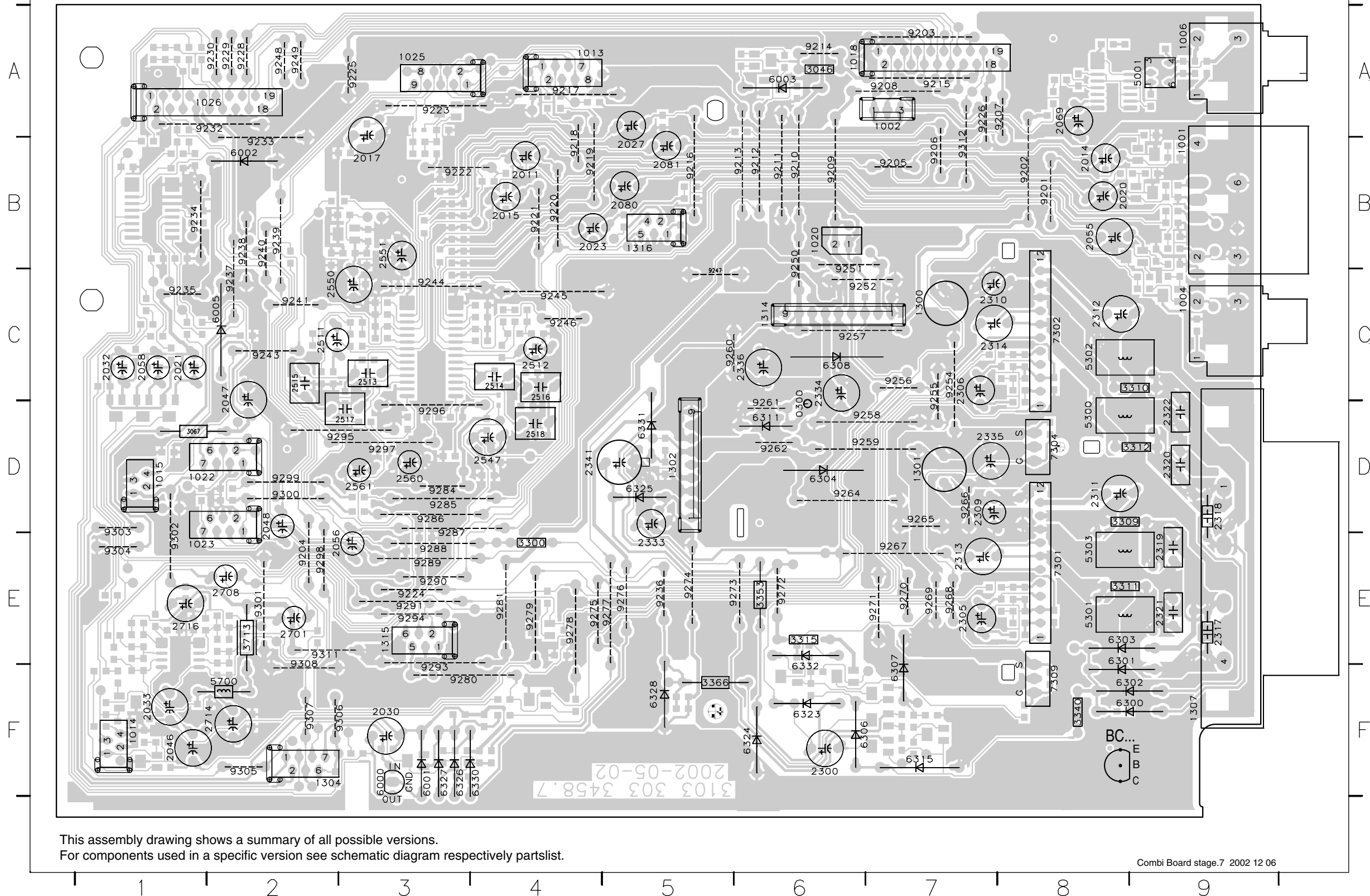

This assembly drawing shows a summary of all possible versions.
 For components used in a specific version see schematic diagram respectively partlist.

COMBI BOARD

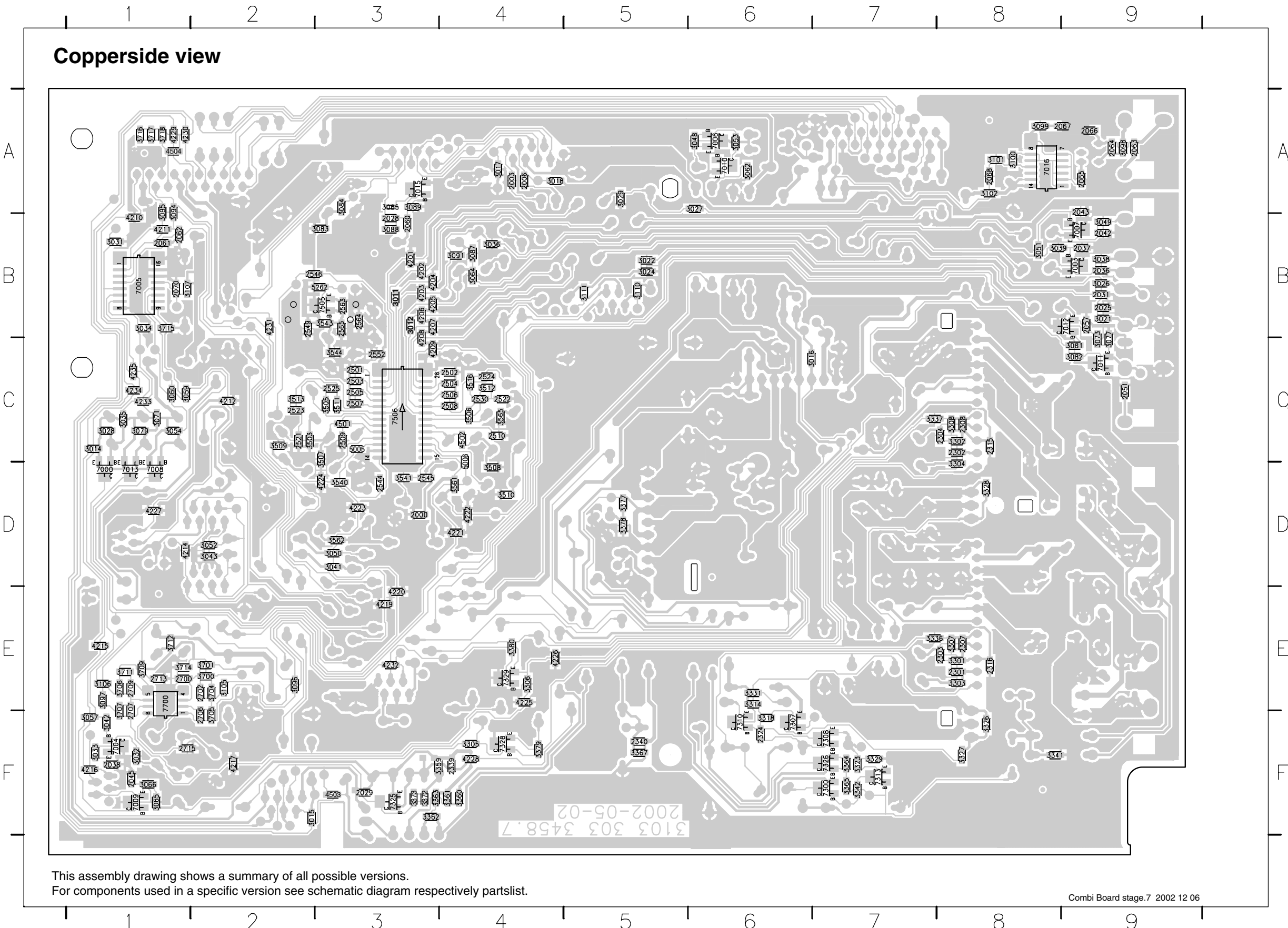

2000 D3	2042 B9	2065 A9	2308 C8	2505 C3	2525 C3	2700 E1	3015 F2	3029 A5	3042 F1	3059 C1	3081 C9	3095 A1	3107 B1	3308 C8	3337 C7	3367 F5	3507 C3	3543 B3	3707 F1	4202 B3	4212 C2	4224 D3	4234 C1	7003 B9	7013 D1	7328 F4
2003 A4	2043 A9	2066 A9	2315 C8	2506 C4	2530 C4	2702 E2	3016 C6	3031 B1	3043 D2	3060 C1	3082 C9	3096 E2	3110 B5	3314 E6	3341 F8	3372 F3	3508 D4	3544 C3	3709 E1	4203 B3	4214 D1	4225 E4	4235 C1	7004 F1	7015 A3	7329 E4
2006 A4	2045 F1	2067 A9	2316 E8	2507 C3	2544 D3	2706 F2	3017 A4	3032 F1	3048 A6	3062 A6	3083 B3	3097 E1	3111 B5	3318 F6	3342 F7	3373 F3	3509 C2	3561 D4	3711 E1	4204 B3	4215 E1	4226 E4	4236 C3	7005 B1	7016 A8	7505 B3
2025 B9	2051 C9	2068 A8	2324 F6	2508 C4	2545 D3	2707 F1	3018 A4	3033 F1	3049 B9	3064 B4	3084 A3	3098 A9	3301 E8	3323 F7	3359 F3	3377 D5	3510 D4	3562 D3	3712 E1	4205 B3	4216 F1	4227 D1	4502 C4	7006 A6	7300 F7	7506 C3
2028 B3	2057 B9	2070 B1	2339 F4	2509 C3	2546 B2	2709 E1	3021 B9	3034 B1	3050 D3	3065 F1	3085 A3	3099 A8	3302 C8	3326 F8	3360 F4	3378 D5	3511 C3	3565 C4	3714 E1	4206 B3	4217 F2	4228 F4	4503 F3	7007 B9	7307 F6	7700 E1
2029 F3	2060 B3	2301 E8	2340 F5	2510 C4	2549 B2	2713 E1	3022 B5	3035 C1	3051 B8	3066 F1	3087 B4	3100 A8	3303 E8	3327 F8	3351 F3	3379 F4	3512 C4	3700 E2	3715 B1	4207 B3	4219 E3	4229 A1	4504 A1	7008 D1	7308 F7	
2031 B9	2061 B1	2302 C8	2501 C3	2521 C2	2552 C3	2715 F1	3024 B6	3036 B4	3052 D2	3071 C1	3088 B3	3101 A8	3304 D8	3328 F8	3362 F3	3380 E4	3513 C2	3701 E2	3716 A1	4208 C3	4220 E3	4230 A1	5005 C3	7009 F1	7310 F6	
2036 B9	2062 B1	2303 E8	2502 C4	2522 C4	2563 B3	3011 B3	3026 B9	3038 B9	3053 A6	3073 C9	3089 A3	3102 A8	3305 F4	3329 F7	3363 F3	3503 C2	3516 C4	3704 E2	3717 A1	4209 C3	4221 D4	4231 B2	5006 D4	7010 A6	7313 F7	
2037 B9	2063 A9	2304 C8	2503 C3	2523 C2	2564 B3	3012 B3	3027 A6	3039 B8	3054 C1	3077 C9	3091 B4	3105 E2	3306 E4	3331 E6	3364 F7	3505 C3	3540 D3	3705 F2	3718 A1	4210 B1	4222 D4	4232 E3	5262 B3	7011 C9	7325 F3	
2038 F1	2064 A9	2307 E8	2504 C4	2524 C4	2565 B3	3014 C1	3028 C1	3041 D3	3057 F1	3079 C1	3094 A1	3106 E1	3307 E8	3336 E7	3365 F7	3506 C4	3541 D3	3706 E1	4201 B3	4211 B1	4223 D3	4233 C3	7000 D1	7012 B9	7326 F7	

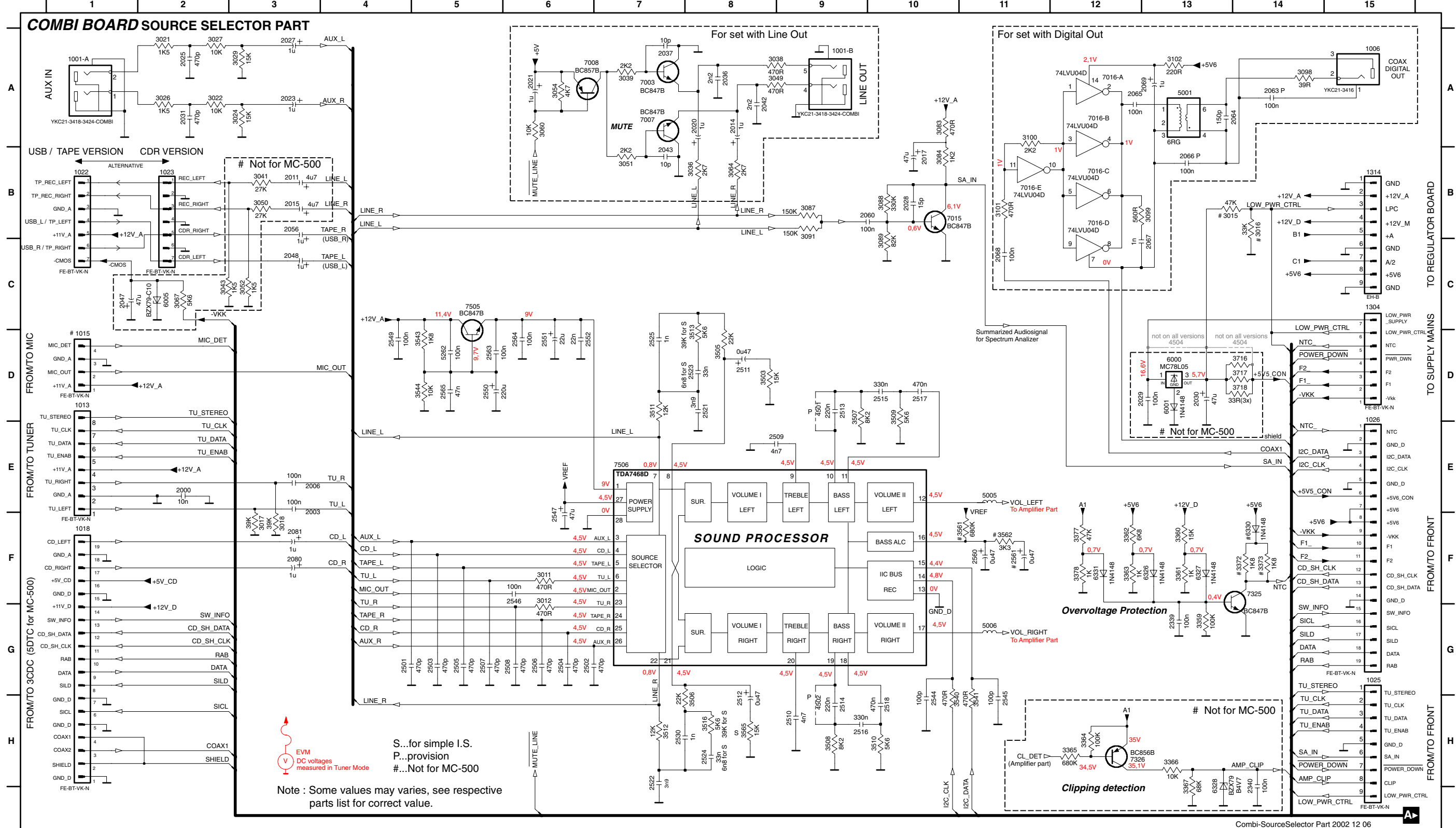

COMBI CIRCUIT - SOURCE SELECTOR PART

1001-A A1	1025 G15	2015 B3	2031 A2	2064 A13	2502 G6	2512 H8	2524 H8	2552 D6	3021 A2	3043 A2	3084 B9	3102 A13	3503 D8	3516 H8	3718 E14	6326 G13	7016-D B12
1001-B A9	1026 E15	2017 B9	2036 A8	2065 A12	2503 G5	2513 D9	2525 D7	2560 D11	3022 A3	3049 A8	3085 B10	3110 A3	3505 D8	3540 H10	4501 D9	6327 G13	7016-E B11
1002 A15	1304 C15	2020 A8	2037 A7	2066 B13	2504 G6	2514 H9	2530 H7	2561 D11	3024 A3	3050 B3	3087 B9	3111 A3	3506 H8	3541 H11	4502 H9	6331 G12	7016-F A11
1006 A15	1314 B15	2021 A6	2042 A8	2067 C13	2505 G5	2515 D10	2544 H10	2563 D5	3026 A2	3051 B7	3088 B10	3359 G13	3507 D9	3543 D5	4503 D13	7003 A7	7325 G14
1013 D1	1316 A4	2023 A3	2043 B7	2068 C11	2506 G6	2516 H9	2545 H11	2564 D6	3027 A3	3052 B3	3089 C10	3360 F13	3508 H9	3544 D5	4504 D14	7007 A7	7505 C5
1015 D1	2000 E2	2025 A2	2047 C1	2069 A13	2507 G5	2517 D10	2546 F6	2565 D5	3029 A3	3054 A6	3091 C9	3361 G13	3509 D10	3561 D10	5001 A13	7008 A6	7506 E7
1018 F1	2003 E3	2027 A3	2048 C3	2080 F3	2508 G6	2518 H10	2547 E6	2565 D5	3036 B8	3060 A6	3098 A14	3362 F13	3510 H10	3562 D11	5262 D5	7015 B10	
1020 H13	2006 E3	2028 B10	2056 B3	2081 F3	2509 E8	2521 D8	2549 D4	2564 D6	3038 A8	3064 B8	3099 B13	3363 G12	3511 D7	3565 H8	6000 D13	7016-A A12	
1022 B1	2011 B3	2029 D13	2060 B9	2339 G13	2510 H9	2522 H7	2550 D5	3017 E3	3039 A7	3067 C2	3100 A11	3377 G12	3512 H7	3716 D14	6001 D13	7016-B A12	
1023 B2	2014 A8	2030 D13	2063 A14	2501 G4	2511 D8	2523 D8	2551 D6	3018 E3	3041 B3	3083 B9	3101 B11	3378 G12	3513 D8	3717 E14	6005 C2	7016-C B12	



 EVM
 DC voltages measured in Tuner Mode
 S...for simple I.S.
 P...provision
 #...Not for MC-500
 Note: Some values may vary, see respective parts list for correct value.

COMBI CIRCUIT - AMPLIFIER PART

0300 C10	1307-A F14	2045 H2	2061 I13	2303 A7	2309 A9	2315 B9	2321 F13	2336 B2	2706 F3	2715 D4	3033 H4	3053 I8	3071 G4	3094 I13	3107 H14	3305 C6	3311 B10
1004 F1	1307-B E14	2046 C5	2062 I13	2304 E7	2310 E9	2316 G9	2322 F12	2340 C14	2707 C3	2716 D1	3034 H10	3057 H4	3073 F2	3095 I13	3300 F7	3306 F7	3312 F10
1014 G1	1315 B1	2051 F1	2070 I14	2305 A7	2311 A10	2317 F13	2324 B14	2341 A3	2708 D1	3014 G2	3035 I5	3059 I10	3077 F2	3096 E4	3301 A7	3307 C8	3314 A14
1300 E9	2032 I5	2055 F4	2300 D9	2306 E7	2312 E10	2318 F12	2333 F7	2700 E3	2709 C3	3028 I5	3042 H3	3062 I9	3079 G4	3097 D4	3302 E7	3308 G8	3315 A12
1301 A9	2033 E5	2057 F2	2301 A7	2307 C8	2313 B10	2319 F13	2334 B1	2701 E1	2713 D3	3031 H10	3046 I7	3065 H5	3081 G3	3105 C2	3303 A8	3309 A10	3318 A13
1302 A1	2038 H2	2058 G4	2302 E7	2308 G8	2314 F10	2320 F12	2335 B2	2702 E3	2714 E3	3032 H4	3048 I8	3066 H5	3082 G3	3106 C2	3304 E7	3310 E10	3323 C13

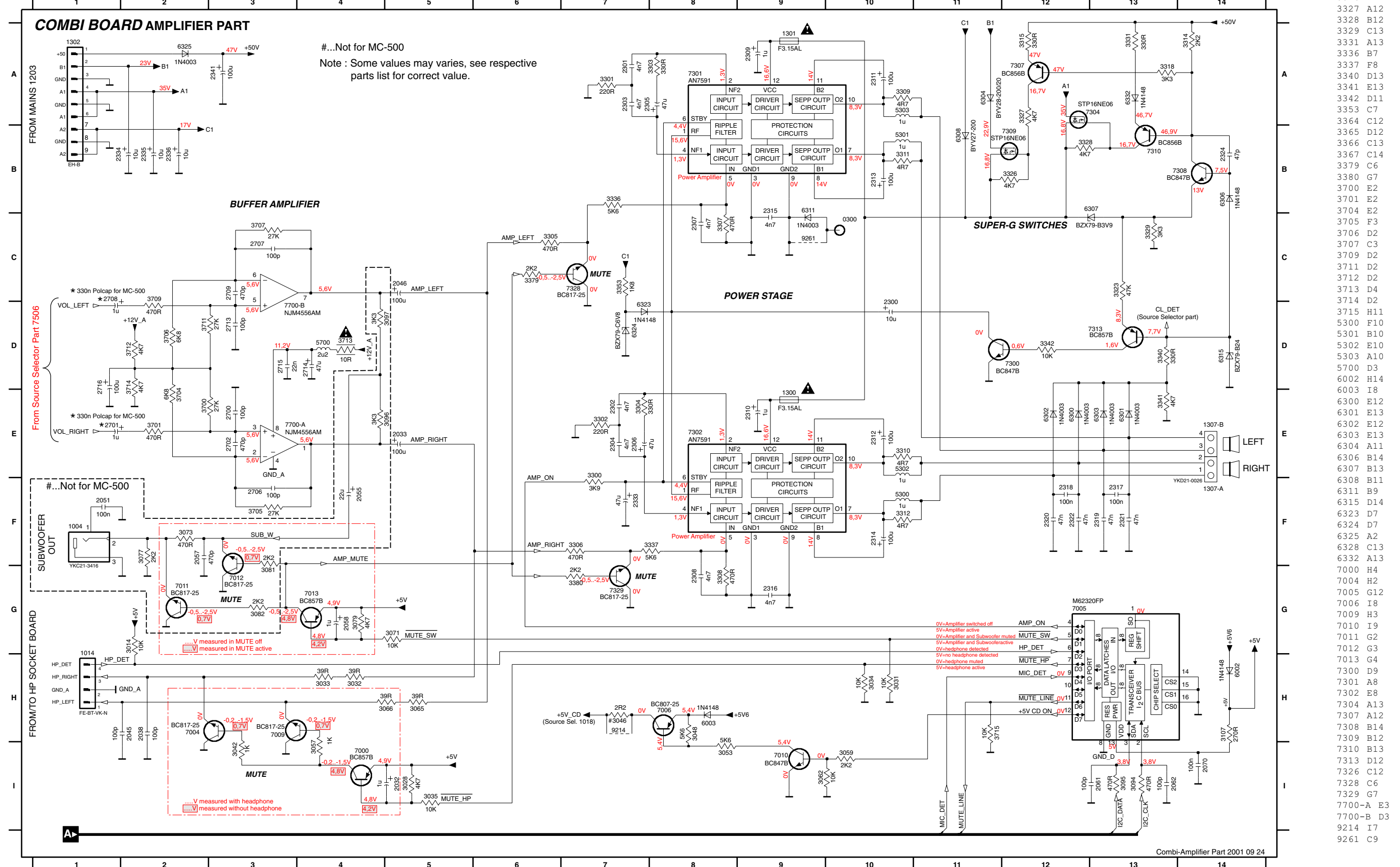

3326 B12	3327 A12	3328 B12	3329 C13	3331 A13	3336 B7	3337 F8	3340 D13	3341 E13	3342 D11	3353 C7	3364 C12	3365 D12	3366 C13	3367 C14	3379 C6	3380 G7	3700 E2	3701 E2	3704 E2	3705 F3	3706 D2	3707 C3	3709 D2	3711 D2	3712 D2	3713 D4	3714 D2	3715 H11	5300 F10	5301 B10	5302 E10	5303 A10	5700 D3	6002 H14	6003 I8	6300 E12	6301 E13	6302 E12	6303 E13	6304 A11	6306 B14	6307 B13	6308 B11	6311 B9	6315 D14	6323 D7	6324 D7	6325 A2	6328 C13	6332 A13	7000 H4	7004 H2	7005 G12	7006 I8	7009 H3	7010 I9	7011 G2	7012 G3	7013 G4	7300 D9	7301 A8	7302 E8	7304 A13	7308 B14	7309 B12	7310 B13	7313 D12	7326 C12	7328 C6	7329 G7	7700-A E3	7700-B D3	9214 I7	9261 C9
----------	----------	----------	----------	----------	---------	---------	----------	----------	----------	---------	----------	----------	----------	----------	---------	---------	---------	---------	---------	---------	---------	---------	---------	---------	---------	---------	---------	----------	----------	----------	----------	----------	---------	----------	---------	----------	----------	----------	----------	----------	----------	----------	----------	---------	----------	---------	---------	---------	----------	----------	---------	---------	----------	---------	---------	---------	---------	---------	---------	---------	---------	---------	----------	----------	----------	----------	----------	----------	---------	---------	-----------	-----------	---------	---------

ELECTRICAL PARTS - REGULATOR BOARD

1171 △ 4822 071 51002 FUSE 19372(1A)
 3418 4822 117 12063 NTC DC 5W 10K 5%
 3421 △ 4822 052 10568 5R60 5% 0,33W
 7403 9322 139 23687 TRA POW BDX53BFP
 7417 4822 209 31841 IC L7805CP

Note: Only these parts mentioned in the list are normal service parts.

ELECTRICAL PARTS - COMBI BOARD

1001 4822 265 20553 SOCKET CINCH 2P - AUX IN
 1300 △ 4822 252 11225 FUSE 3,15A
 1301 △ 4822 252 11225 FUSE 3,15A
 1307 9940 000 02095 SPK TERMINAL TC08-412-0
 3713 △ 4822 052 10109 10R00 5% 0,33W

 7005 4822 209 17345 IC M62320FP
 7301 9322 153 02682 IC AN7591
 7302 9322 153 02682 IC AN7591
 7304 4822 130 11578 FET POW STP16NE06
 7309 4822 130 11336 FET POW STP16NE06

 7506 9322 150 74668 IC SM TDA7468D (ST00) R
 7700 4822 209 31378 IC NJM4556MB
 9940 000 02119 FFC CABLE 15P L=150MM WHITE
 9940 000 02121 FFC CABLE 4P L=340MM

Note: Only these parts mentioned in the list are normal service parts.

SET MECHANICAL EXPLODED VIEW

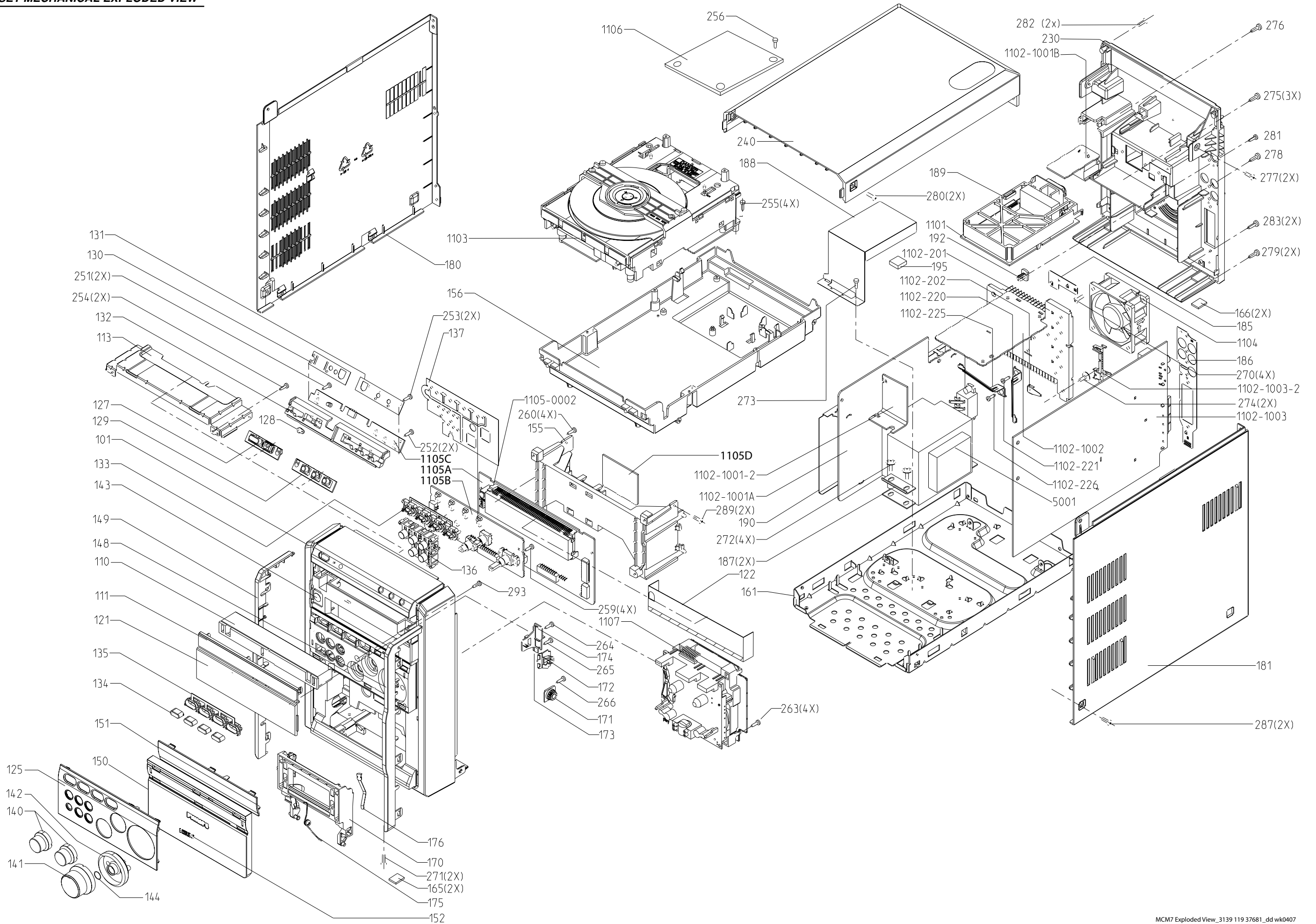

MECHANICAL & ACCESSORIES**SCREW LISTS - MAIN UNIT**

P001	9940 000 02087	COVER CD TRAY PRE ASS'Y	3139 238 06511	REMOTE CONTROL	251	D2 x 8	
	Includes:		9940 000 02081	SPEAKER BOX 6OHM 50W	252	D2 x 8	
	0110	9940 000 02089	BRACKET-CD DOOR	2422 549 45067	ANT AM LOOP LAN-006 B	253	D2 x 8
	0111	9940 000 02088	DOOR-CD	△ 9940 000 02082	AC CORD VDE 2C L=1.5M /22	254	D2 x 8
			△ 9940 000 02178	AC CORD BSI /25	255	D3 x 20	
P002	9940 000 02091	COVER CASSETTE PRE ASS'Y					
	Includes:		9940 000 02078	WMA CD ASS'Y	256	D3 x 8	
	0121	LENS DISPLAY	9940 000 02079	CASS. BOARD ASS'Y	259	M3 x 12	
	0127	BUTTON-STANDBY POWER	9940 000 02101	RDS BOARD ASS'Y	260	D3 x 10	
	0129	BUTTON SET RDS/NEWS	9940 000 02111	MOTOR BOARD ASS'Y	263	D3 x 12	
			9940 000 02131	TUNER BOARD ASS'Y	264	D3 x 12	
	0150	COVER CASSETTE			265	M3 x 12	
	0151	PANEL CASSETTE			266	M3 x 12	
	0170	9940 000 02132	DOOR-CASSETTE		270	D3 x 35	
P004	9940 000 02086	CABINET FRONT ASS'Y			271	M3 x 6	
	Includes:				272	M3 x 10	
	0101	CABINET FRONT			273	M3 x 6	
	0125	PANEL CONTROL			274	M3 x 10	
	0133	BUTTON-SOURCE			275	D3 x 10	
					276	D3 x 10	
	0134	CAP SOURCE			277	D3 x 10	
	0136	BUTTON SET FUNCTION			278	D3 x 10	
	0165	9940 000 02094	FOOT RUBBER 4MM		279	M3 x 10	
	0171	9940 000 01664	DAMPER GEAR ASSEMBLY		280	M3 x 10	
	0175	3139 111 01390	SPRING TORSION LEFT		281	D3 x 16	
					282	D3 x 12	
	0176	4822 492 42787	SPRING CASSETTE		283	D3 x 10	
0140	9940 000 02136	KNOB-BASS/TREBLE			287	M3 x 10	
0141	9940 000 02135	KNOB-VOLUME			289	D3 x 10	
0144	4822 492 51374	RING			293	D2 x 8	
0166	9940 000 02094	RUBBER-FOOT 4MM					
0173	9940 000 02093	SPRING-COMPRESSION					
0180	9940 000 02083	PANEL-LEFT					
0181	9940 000 02084	PANEL-RIGHT					
0230	9940 000 02085	CABINET-REAR					
0240	9940 000 02133	PANEL-TOP					
1103	9940 000 02092	CD MECHANISM LOADER					
1107	3139 118 78740	TAPE DECK CRL 4438					

Note: Only these parts mentioned in the list are normal service parts.